



**pennsylvania**

DEPARTMENT OF TRANSPORTATION

# Environmental and Cost Effectiveness of Partially Grouted Riprap for Scour Countermeasure

FINAL REPORT

August 30, 2019

By (PI): Bechara Abboud, Ph.D., P.E., and  
(CO-PI) Joseph Coe, Ph.D.  
Temple University

COMMONWEALTH OF PENNSYLVANIA  
DEPARTMENT OF TRANSPORTATION

CONTRACT # 4400011166  
WORK ORDER # TEM WO 001



*Page Intentionally Left Blank*

<b>1. Report No.</b> FHWA-PA-2019-004-TEM WO 001		<b>3. Recipient's Catalog No.</b>		<b>3. Recipient's Catalog No.</b>	
<b>4. Title and Subtitle</b> Environmental and Cost Effectiveness of Partially Grouted Riprap for Scour Countermeasure				<b>5. Report Date</b> 08/30/2019	
				<b>6. Performing Organization Code</b>	
<b>7. Author(s)</b> Bechara Abboud, Ph.D., P.E., and Joseph Coe, Ph.D.				<b>8. Performing Organization Report No.</b>	
<b>9. Performing Organization Name and Address</b> Temple University Department of Civil & Environmental Engineering 1947 N.12th St Philadelphia, PA 19122				<b>10. Work Unit No. (TR AIS)</b>	
				<b>11. Contract or Grant No.</b> 4400011166, TEM WO 001	
<b>12. Sponsoring Agency Name and Address</b> The Pennsylvania Department of Transportation Bureau of Planning and Research Commonwealth Keystone Building 400 North Street, 6 <sup>th</sup> Floor Harrisburg, PA 17120-0064				<b>13. Type of Report and Period Covered</b> Final Report 05/05/2014 – 08/30/2019	
				<b>14. Sponsoring Agency Code</b>	
<b>15. Supplementary Notes</b> Technical Advisor: Mittal Patel, P.E., Assistant District Bridge Engineer, Department of Transportation, Engineering District 6-0, 7000 Geerdes Blvd, King of Prussia, PA 19406, Phone: 610.205-6625, Fax: 610.205.6911, <a href="mailto:mitpatel@pa.gov">mitpatel@pa.gov</a>					
<b>16. Abstract</b> Partially grouted riprap (PGR) as a scour countermeasure is relatively new in the United States but has been used widely in Europe. Currently in Pennsylvania, the selection of appropriate scour countermeasures for bridge foundation protection have in general been limited in their applications to mainly dumped or hand-placed riprap, which can be displaced after major flood event. Hence, there is a critical need to develop guidelines to utilize PGR as a permanent countermeasure to control scour at bridge piers and abutments. The goal of this research project was to develop guidelines for scour countermeasure at piers and abutments using PGR in-the-dry and in-the-wet as a permanent countermeasure for scour control and remediation that minimizes environmental impacts, construction feasibility and demonstrates strong cost benefit/low life cycle costs. With the assistance of PennDOT District 6-0 Technical Advisor, an existing scour critical bridge SR 2028 was selected to have PGR as a permanent scour countermeasure to protect the structure from scour.  Taking into consideration HEC-23 "Design Guideline 12"(1), draft design guidelines of PGR at bridge piers and abutments in-the-dry and in-the-wet was developed in collaboration and advisement on the technical direction of the research project by the Technical Advisor of PennDOT District 6-0 and the Technical Panel (regulatory agencies) of DEP and COE. The draft design guidelines included a description of PGR, materials, design standards, filter requirements, construction specifications in-the-dry and in-the-wet, water quality management, and measurement and payment.  At the preapplication meeting for the recommended permit, the regulatory agencies, COE and DEP, rejected the General Permit GP-11 for the proposed placement of PGR in-the-wet at bridge SR 2028. The COE and DEP requested that the permit application be evaluated under the highest level of permitting, Department of Army Individual Permit (IP). The COE also specifically required a 404(b)(1) Guideline Analysis, which includes rigorous purpose, need, and alternative analysis. When comparing GP-11 to an IP permit, it became apparent that the IP permit required significantly more information, substantial preparation and time, and more construction details than GP-11. Since IP Permit was not within the scope of the research project, it was decided to construct the PGR at bridge SR 2028 in-the-dry under General Permit GP-11.  The research project provided the much-needed tools for utilizing PGR as a lasting remedial scour countermeasure for existing scour critical bridges and as permanent scour countermeasure for bridges in District 6-0 and in the State of Pennsylvania. The developed design guideline of PGR in-the-dry at bridge piers and abutments will allow a uniform, practical, effective, and economical approach and design of scour countermeasure for PennDOT districts with scour-critical bridges. The application of the research resulted in utilizing PGR as the most functional and cost-effective scour countermeasure with improvement to environmental and streambed conditions at bridge SR 2028. To implement the findings in this research project, this report should be reviewed and commented on by all the districts in Pennsylvania with the intention for implementation as recommended practice. Additionally, this report should be submitted to the State Transportation Innovation Council (STIC) for broader development and deployment.  Although this research project can be used as a standalone document, it would be beneficial to conduct further, complimentary research on PGR in-the-wet. The research study of PGR in-the-wet should quantify the environmental impacts with the initial impact of construction and maintenance on the water quality and aquatic life. Such research would allow the State of Pennsylvania to expand their knowledge and experience with PGR as a scour countermeasure and create more economical and functional practices throughout the state.					
<b>17. Key Words</b> partially grouted riprap, scour critical bridge, countermeasure, design guidelines, in-the-dry, in-the-wet, specification, permit IP and GP-11, construction, water quality, regulatory agencies				<b>18. Distribution Statement</b> No restrictions. This document is available from the National Technical Information Service, Springfield, VA 22161	
<b>19. Security Classif. (of this report)</b> Unclassified		<b>20. Security Classif. (of this page)</b> Unclassified		<b>21. No of Pages</b>	<b>20. Price</b> N/A

*Page Intentionally Left Blank*

## DISCLAIMER

---

This work was sponsored by the Pennsylvania Department of Transportation and the U.S. Department of Transportation, Federal Highway Administration. The contents of this report reflect the views of the authors, who are responsible for the facts and the accuracy of the data presented herein. The contents do not necessarily reflect the official views or policies of the Federal Highway Administration, U.S. Department of Transportation, or the Commonwealth of Pennsylvania at the time of publication. This report does not constitute a standard, specification, or regulation.

The authors, the US Department of Transportation, Federal Highway Administration, or the Commonwealth of Pennsylvania do not endorse products or manufacturers. Any trade, firm names, or manufacturers' names that may appear herein do so solely for identification purposes and because they are considered essential to this report.

## ACKNOWLEDGEMENTS

---

The financial and technical support provided by the Pennsylvania Department of Transportation (PennDOT) and the U.S. Department of Transportation, Federal Highway Administration for this project is gratefully acknowledged. The authors would like to extend their sincere gratitude to the project manager Ms. Teresa Swisher for all her support throughout the project. The authors are also extremely grateful to District 6-0 especially Ms. Mittal Patel and Mr. Peter Berg (former District 6-0 Assistant District Bridge Engineer) for their tireless guidance, helpful comments and support throughout the project. The authors would also like to thank the graduate students Ms. Sarah Delcasale and Mr. Basel Yandem and all the undergraduate students worked on this project for their efforts in the laboratory testing and the construction of PGR.

# TABLE OF CONTENTS

---

<b>DISCLAIMER</b> .....	<b>I</b>
<b>ACKNOWLEDGEMENTS</b> .....	<b>II</b>
<b>TABLE OF CONTENTS</b> .....	<b>III</b>
<b>LIST OF APPENDICES</b> .....	<b>VI</b>
<b>LIST OF TABLES</b> .....	<b>VII</b>
<b>LIST OF FIGURES</b> .....	<b>VIII</b>
<b>LIST OF PHOTOS</b> .....	<b>IX</b>
<b>EXECUTIVE SUMMARY</b> .....	<b>1</b>
<b>CHAPTER 1: INTRODUCTION &amp; RESEARCH APPROACH</b> .....	<b>2</b>
1.1 INTRODUCTION & RESEARCH OBJECTIVES .....	2
1.1.1 <i>Background</i> .....	2
1.1.2 <i>Scope of Work &amp; Problem Statement</i> .....	3
1.2 RESEARCH TASKS .....	4
1.2.1 <i>Task 1 – Literature Search</i> .....	4
1.2.2 <i>Task 2 – Development of Bridge Scour Countermeasure Design Guidelines For Piers and Abutments Using PGR</i> .....	5
1.2.3 <i>Task 3 – Selection of One Scour Critical Bridge in PennDOT District 6-0</i> .....	5
1.2.4 <i>Task 4 – Application of the Research Results to District 6 Selected Bridge - REVISED</i> .....	6
1.2.5 <i>Task 5 – Construction of Scour Countermeasure at the Selected Bridge Piers and Abutment Using PGR - REVISED</i> .....	7
1.2.6 <i>Task 6 – NBIS Bridge Inspection - REVISED</i> .....	7
1.2.7 <i>Task 7 – Draft Final Report</i> .....	7
1.2.8 <i>Task 8 – Final Report</i> .....	8
1.3 REPORT ORGANIZATION .....	8
<b>CHAPTER 2: LITERATURE RESEARCH FINDINGS</b> .....	<b>9</b>
2.1 SCOUR AT BRIDGE CROSSINGS .....	9
2.2 COUNTERMEASURE .....	9
2.3 PARTIALLY GROUTED RIPRAP AS SCOUR COUNTERMEASURE .....	10
<b>CHAPTER 3: DRAFT DESIGN GUIDELINES OF PGR AT BRIDGE PIERS AND ABUTMENTS IN-THE-DRY AND IN-THE-WET, AND APPLICATION OF PGR TO SCOUR CRITICAL BRIDGE IN PENNDOT DISTRICT 6-0</b> .....	<b>15</b>
3.1 DRAFT DESIGN GUIDELINES OF PGR AT BRIDGE PIERS AND ABUTMENTS IN-THE-DRY AND IN-THE-WET .....	15
3.1.1 <i>Description</i> .....	15
3.1.2 <i>Materials</i> .....	15

3.1.2.1	Rock .....	16
3.1.2.2	Grout.....	16
3.1.2.2.1	Grout Mix .....	17
3.1.2.2.2	Field Quality Assurance Requirements.....	18
3.1.2.2.3	Consistency “Spread-Test” Requirements.....	18
3.1.2.3	Combined Geotextile and Granular Filter .....	19
3.1.3	<i>Turbidity Curtain</i> .....	19
3.1.4	<i>Design Standards</i> .....	20
3.1.4.1	Layout Dimensions .....	20
3.1.4.1.1	Piers.....	20
3.1.4.1.2	Abutments.....	20
3.1.5	<i>Construction Specifications</i> .....	23
3.1.5.1	General .....	23
3.1.5.2	Contractor Requirements .....	23
3.1.5.3	Excavation .....	24
3.1.5.3.1	General.....	24
3.1.5.3.2	Excavation In-The-Dry .....	24
3.1.5.3.3	Excavation In-The-Wet.....	25
3.1.5.4	Combined Filter Placement.....	25
3.1.5.4.1	General.....	25
3.1.5.4.2	In-The-Dry .....	25
3.1.5.4.3	In-The-Wet .....	25
3.1.5.5	Riprap Placement.....	27
3.1.5.5.1	In-The-Dry .....	27
3.1.5.5.2	In-The-Wet .....	27
3.1.5.6	Grouting.....	28
3.1.5.6.1	In-The-Dry .....	28
3.1.5.6.2	In-The-Wet .....	29
3.1.5.7	Dewatering.....	30
3.1.5.8	Sedimentation and Erosion Control System .....	30
3.1.5.9	7.4 Water Quality Management .....	30
3.1.5.10	Turbidity Curtain Placement .....	30
3.1.6	<i>Water Quality Management</i> .....	31
3.1.6.1	General .....	31
3.1.6.2	Placement of PGR in-the-dry.....	32
3.1.6.3	Placement of PGR in-the-wet.....	32
3.1.6.3.1	General Requirements .....	32
3.1.6.3.2	Monitoring Water Quality.....	33
3.1.7	<i>Measurement and Payment</i> .....	35
3.1.7.1	Measurement .....	35
3.1.7.2	Basis of Payment.....	35
3.2	PERMIT APPLICATION OF PGR TO SCOUR CRITICAL BRIDGE IN PENNDOT DISTRICT 6-0 .....	36
3.2.1	<i>Outcome of Preapplication Meeting with COE and DEP</i> .....	37
3.3	MODIFICATION OF PGR PERMIT APPLICATION TO SCOUR CRITICAL BRIDGE SR 2028 IN PENNDOT DISTRICT 6-0 .....	43
<b>CHAPTER 4: APPLICATION OF PGR IN-THE-DRY TO PENNDOT DISTRICT 6-0 SCOUR CRITICAL BRIDGE SR 202846</b>		
4.1	SITE DESCRIPTION .....	46
4.2	EROSION AND SEDIMENT CONTROL PLAN – SEQUENCE OF CONSTRUCTION .....	48
4.3	SPECIFICATION ITEM 9000-0002 PARTIALLY GROUTED RIPRAP.....	52
4.4	TEST-PIT .....	56

4.5	CONSTRUCTION OF PGR SCOUR COUNTERMEASURE AT PENNDOT BRIDGE SR 2028 .....	60
4.5.1	<i>Environment Testing and Monitoring of PGR Construction at Bridge SR 2028.....</i>	<i>68</i>
4.5.2	<i>On-Site Assessment After PGR Construction at Bridge Sr 2028 Pier and Abutment .....</i>	<i>73</i>
4.6	REVISED DESIGN GUIDELINES OF PGR AT BRIDGE PIERS AND ABUTMENTS .....	86
4.6.1	<i>Description .....</i>	<i>86</i>
4.6.1.1	Materials .....	86
4.6.1.1.1	Rocks .....	86
4.6.1.1.2	Geotextile.....	86
4.6.1.1.3	Granular Filter .....	86
4.6.1.1.4	Grout .....	86
4.6.1.1.5	Combined Geotextile and Granular Filter .....	88
4.6.2	<i>Design Standards .....</i>	<i>89</i>
4.6.2.1	Layout Dimensions.....	89
4.6.2.1.1	Piers.....	89
4.6.2.1.2	Abutments.....	89
4.6.3	<i>Construction In-The-Dry Specification.....</i>	<i>89</i>
4.6.3.1	General .....	89
4.6.3.2	Contractor Requirements .....	92
4.6.3.3	Excavation .....	92
4.6.3.4	Combined Filter Placement.....	94
4.6.3.5	Riprap Placement .....	94
4.6.3.6	Grout.....	94
4.6.3.7	Dewatering.....	95
4.6.3.8	Sedimentation and Erosion Control System .....	95
4.6.3.9	Water Quality Management .....	95
4.6.4	<i>Measurement and Payment .....</i>	<i>96</i>
4.6.4.1	Measurement .....	96
4.6.4.2	Basis of Payment.....	96
<b>CHAPTER 5:</b>	<b>CONCLUSIONS &amp; RECOMMENDATIONS .....</b>	<b>97</b>
5.1	SUMMARY .....	97
5.2	CONCLUSIONS .....	100
5.3	IMPLEMENTATION & RECOMMENDATIONS.....	101
<b>REFERENCES.....</b>	<b>.....</b>	<b>102</b>
<b>APPENDICES.....</b>	<b>.....</b>	<b>104</b>

## LIST OF APPENDICES

---

<b>EXECUTIVE SUMMARY .....</b>	<b>1</b>
<b>APPENDIX A “ROCK RIPRAP/SIZE” .....</b>	<b>105</b>
<b>APPENDIX B “TEST RESULTS OF EXPERIMENTAL RESEARCH ON GROUT DESIGN MIX” .....</b>	<b>114</b>
<b>APPENDIX C “HYDROLOGIC AND HYDRAULIC (H&amp;H) ANALYSIS AND SUMMARY OF PGR SCOUR COUNTERMEASURE DESIGN PARAMETERS” .....</b>	<b>147</b>
<b>APPENDIX D “RECOMMENDED PS&amp;E (PLANS, SPECS, &amp; ESTIMATE) PACKAGE” .....</b>	<b>169</b>
<b>APPENICES FOR APPENDIX C .....</b>	<b>200</b>

## LIST OF TABLES

---

<b>EXECUTIVE SUMMARY .....</b>	<b>1</b>
<b>TABLE 1: SIZE AND GRADATION OF THE MODIFIED CLASS SIZE NO .....</b>	<b>16</b>
<b>TABLE 2: TARGET GROUT MIX DESIGN .....</b>	<b>17</b>
<b>TABLE 3: GROUT DIAMETER DURING SPREAD TEST .....</b>	<b>18</b>
<b>TABLE 4: TURBIDITY CURTAIN REQUIREMENTS.....</b>	<b>19</b>
<b>TABLE 5: GROUTING RATE IN-THE-DRY GROUTING MATERIAL QUANTITIES.....</b>	<b>29</b>
<b>TABLE 6: GROUTING RATE IN THE WET GROUTING MATERIAL QUANTITIES .....</b>	<b>30</b>
<b>TABLE 7 ESTIMATED CONSTRUCTION COST OF PGR SCOUR COUNTERMEASURE .....</b>	<b>52</b>
<b>TABLE 8: TARGET GROUT MIX DESIGN .....</b>	<b>53</b>
<b>TABLE 9: GROUTING RATE IN-THE-DRY GROUTING MATERIAL QUANTITIES.....</b>	<b>55</b>
<b>TABLE 10 MODIFIED ESTIMATED CONSTRUCTION COST OF PGR SCOUR COUNTERMEASURE .....</b>	<b>61</b>
<b>TABLE 11 COMPARISON BETWEEN ESTIMATED AND ACTUAL CONSTRUCTION COST OF PGR SCOUR COUNTERMEASURE AT BRIDGE SR 2028 .....</b>	<b>68</b>
<b>TABLE 12 SUMMARY OF INSPECTION REPORTS .....</b>	<b>80</b>
<b>TABLE 13: TARGET GROUT MIX DESIGN .....</b>	<b>87</b>
<b>TABLE 14: GROUT DIAMETER DURING SPREAD TEST.....</b>	<b>88</b>
<b>TABLE 15: GROUTING RATE IN-THE-DRY GROUTING MATERIAL QUANTITIES.....</b>	<b>95</b>

## LIST OF FIGURES

---

<b>EXECUTIVE SUMMARY .....</b>	<b>1</b>
<b>FIGURE 1 EXISTING PIER PGR LAYOUT DIMENSIONS .....</b>	<b>21</b>
<b>FIGURE 2 EXISTING ABUTMENT PGR LAYOUT DIMENSIONS.....</b>	<b>22</b>
<b>FIGURE 3 PGR MOCK-UP TRAINING TEST-PIT .....</b>	<b>26</b>
<b>FIGURE 4 BRIDGE CARRYING STATE ROUTE (SR) 2028 (CAMP HILL ROAD) OVER SANDY RUN .....</b>	<b>47</b>
<b>FIGURE 5 E&amp;S SEQUENCE OF CONSTRUCTION – PHASE 1 .....</b>	<b>50</b>
<b>FIGURE 6 E&amp;S SEQUENCE OF CONSTRUCTION – PHASE2.....</b>	<b>51</b>
<b>FIGURE 7 MODIFIED E&amp;S SEQUENCE OF CONSTRUCTION – PHASE 1.....</b>	<b>62</b>
<b>FIGURE 8 MODIFIED E&amp;S SEQUENCE OF CONSTRUCTION – PHASE2.....</b>	<b>65</b>
<b>FIGURE 9: RESULTS FROM PH TESTING BEFORE, DURING, AND AFTER THE CONSTRUCTION OF PGR AT BRIDGE SR 2028.....</b>	<b>70</b>
<b>FIGURE 10: RESULTS FROM TURBIDITY TESTING BEFORE, DURING, AND AFTER THE CONSTRUCTION OF PGR AT BRIDGE SR 2028 .....</b>	<b>71</b>
<b>FIGURE 11: TEMPERATURE MEASUREMENTS BEFORE, DURING, AND AFTER THE CONSTRUCTION OF PGR AT BRIDGE SR 2028 .....</b>	<b>72</b>
<b>FIGURE 12 WATER DEPTH AT BRIDGE SR 2028 .....</b>	<b>77</b>
<b>FIGURE 13 EXISTING PIER LAYOUT DIMENSIONS.....</b>	<b>90</b>
<b>FIGURE 14 EXISTING ABUTMENT LAYOUT DIMENSIONS .....</b>	<b>91</b>
<b>FIGURE 15 PGR MOCK-UP TRAINING TEST-PIT .....</b>	<b>93</b>

## LIST OF PHOTOS

---

PHOTO 1 SPAN 2 LOOKING UPSTREAM SEDIMENT DEPOSITION .....	48
PHOTO 2 SPAN 1 LOOKING DOWN STREAM FORMATION OF SCOUR HOLE .....	48
PHOTO 3 TEST-PIT FORUM.....	57
PHOTO 4 INTERIOR OF TEST-PIT FORM .....	57
PHOTO 5 TEST-PIT FORM WITH EXTERIOR SUPPORT.....	57
PHOTO 6 SIX-INCH NUMBER 57 TYPE A AGGREGATES SPREAD ON TOP OF THE GEOTEXTILE CLASS 4, TYPE A .....	57
PHOTO 7 PLACEMENT OF ROCKS .....	58
PHOTO 8 FINAL ROCK PLACEMENT IN THE FORM .....	58
PHOTO 9 GROUT ALONGSIDE THE FORM WALL .....	59
PHOTO 10 GROUT FELL TO THE BOTTOM OF THE VOIDS.....	59
PHOTO 11 ELBOW TUBE USED TO DELIVER GROUT.....	59
PHOTO 12 FINAL GROUTING .....	59
PHOTO 13 EXPOSED PGR AFTER 24 HOURS.....	59
PHOTO 14 GROUT SETTLEMENT AT THE BOTTOM .....	59
PHOTO 15 UNFILLED VOIDS .....	60
PHOTO 16 UPSTREAM CONSTRUCTION ENTRANCE.....	63
PHOTO 17A UPSTREAM COFFERDAM .....	63
PHOTO 17B DOWNSTREAM COFFERDAM .....	63
PHOTO 18 DOWNSTREAM ENERGY DISSIPATER.....	63
PHOTO 19 WATER FILTER BAG .....	63
PHOTO 20 PUMP DISCHARGE PIPE IN SPAN 2 .....	63
PHOTO 21 WATER PUMPS .....	63
PHOTO 22 PRECONSTRUCTION CONDITION OF SPAN 1 .....	63
PHOTO 23 LARGE AND MINI TRACK EXCAVATORS .....	64
PHOTO 24 REMOVAL OF EXISTING ROCKS IN SPAN 1.....	64

PHOTO 25 PLACING AASHTO NUMBER 1 COURSE AGGREGATE .....	66
PHOTO 26 PLACING 2-INCH OF AASHTO NO 57 TO LEVEL BASE.....	66
PHOTO 27 PLACEMENT OF COMBINED FILTER .....	66
PHOTO 28 PLACEMENT OF R6 ROCKS ON TOP OF COMBINED FILTER .....	66
PHOTO 29: MODIFIED GROUT END DELIVERY .....	66
PHOTO 30: PLACING GROUT IN VOIDS .....	66
PHOTO 31 GROUT PLACEMENT AT INTERFACE.....	67
PHOTO 32 6-INCHES OF STREAMBED MATERIAL PLACED ON TOP OF PGR .....	67
PHOTO 33 REGRADED STREAMBED WITH LOW CHANNEL IN SPAN 2.....	67
PHOTO 34 POST CONSTRUCTION OF PGR .....	67
PHOTO 37 UPSTREAM VIEW AT BRIDGE SR 2028 .....	73
PHOTO 38 DOWNSTREAM VIEW AT BRIDGE SR 2028.....	74
PHOTO 39 UNDER WATER VIEW OF PGR AT ABUTMENT SIDE .....	74
PHOTO 40 UNDER WATER OF PGR AT PIER SIDE .....	74
PHOTO 41 UNDER WATER VIEW OF LOW-FLOW CHANNEL .....	74
PHOTO 42 FILAMENTOUS ALGAE GROWTH ON TOP OF PGR .....	75
PHOTO 43 UPSTREAM VIEW AT SR 2028 .....	75
PHOTO 44 DOWNSTREAM VIEW AT SR 2028 .....	76
PHOTO 45 DEBRIS AT UPSTREAM OF PIER NOSE AND SPAN 1.....	76
PHOTO 46 SEDIMENTS BUILT-UP AND DEBRIS IN DOWNSTREAM OF SPAN 2 .....	76
PHOTO 47 UNDER WATER VIEW OF PGR AT UPSTREAM OF SPAN 1.....	78
PHOTO 48 UNDER WATER VIEW OF PGR AT MIDDLE OF SPAN 1.....	78
PHOTO 49 UNDER WATER VIEW OF PGR AT DOWNSTREAM OF SPAN 1 .....	78
PHOTO 50 CROSS-SECTION OF THE STREAMBED IN SPAN 2 .....	79

# PennDOT Research Executive Summary

## Selection & Design of Scour Countermeasures for Pennsylvania Bridges

### QUICK INFO:

**Start Date:**

May 5, 2014

**End Date:**

July 31, 2019

**Funding:**

\$500,000.00

**Report Date:**

July 31, 2019

**Performing  
Organization:**

*Bureau of Planning  
& Research*

(p) 717-214-8686

(f) 717-783-9152

**Email:**

PennDOT\_Library@  
state.pa.us

### BACKGROUND

Partially grouted riprap (PGR) as a scour countermeasure is relatively new in the United States but has been used widely in Europe. Currently in Pennsylvania, the selection of appropriate scour countermeasures for bridge foundation protection have in general been limited in their applications to mainly dumped or hand-placed riprap, which can be displaced after major flood event. Hence, there is a critical need to develop guidelines to utilize PGR as a permanent countermeasure to control scour at bridge piers and abutments. The goal of this research project was to develop guidelines for scour countermeasure at piers and abutments using PGR in-the-dry and in-the-wet as a permanent countermeasure for scour control and remediation that minimizes environmental impacts, construction feasibility and demonstrates strong cost benefit/low life cycle costs. With the assistance of PennDOT District 6-0 Technical Advisor, an existing scour critical bridge SR 2028 was selected to have PGR as a permanent scour countermeasure to protect the structure from scour.

### FINDINGS

Draft design guidelines at bridge piers and abutments in-the-dry and in-the-wet as well as design guidelines of PGR at bridge piers and abutments in-the-dry was developed in this research project. The design guidelines provided the technical approach, applicable standards, and specifications for utilizing PGR as a scour countermeasure for bridges in PennDOT District 6-0 and the State of Pennsylvania. The design guidelines included a description of PGR, materials, design standards, filter requirements, construction specifications in-the-dry, water quality management, and measurement and payment.

### RESULTS

The major results from this research project included the following:

- Developed grout mix design for construction in-the-wet and in-the-dry with general guidance of grouting materials for the design guidelines of PGR for piers and abutment.
- The developed design guidelines for PGR at piers and abutments in-the-dry was successfully applied to the scour critical bridge SR 2028 in PennDOT District 6-0.
- Construction of PGR in-the-dry had no effect on the water quality or aquatic life.

### CONCLUSIONS AND RECOMMENDATIONS

This research project provides the much-needed tools for utilizing PGR as a lasting remedial scour countermeasure for existing scour critical bridges and as permanent scour countermeasure for bridges in PennDOT District 6-0 and in the State of Pennsylvania. The developed design guideline of PGR in-the-dry at bridge piers and abutments will allow a uniform, practical, effective, and economical approach and design of scour countermeasure for PennDOT districts with scour-critical bridges. The application of the research resulted in utilizing PGR as the most functional and cost-effective scour countermeasure with improvement to environmental and streambed conditions at PennDOT District 6-0 Bridge SR 2028.

In order to obtain the best possible results from this research project, the information presented in this report must be properly implemented. The developed design guidelines of PGR at bridge piers and abutment in-the-dry provides the technical approach, applicable standards, and specifications for utilizing PGR as a scour countermeasure for bridges in PennDOT District 6-0 and the State of Pennsylvania. To implement the developed and proposed methodologies and procedures in this research project, this report should be reviewed and commented on by all the districts in Pennsylvania with the intention for implementation as recommended practice. Additionally, the well-researched, documented, and proven application of PGR in this report should be submitted to the State Transportation Innovation Council (STIC) for broader development and deployment.

Although this research project can be used as a standalone document, it would be beneficial to conduct further, complimentary research on PGR in-the-wet. The research study of PGR in-the-wet should quantify the environmental impacts with the initial impact of construction and maintenance on the water quality and aquatic life. Such research would allow the State of Pennsylvania to expand their knowledge and experience with PGR as a scour countermeasure and create more economical and functional practices throughout the state.

*Page Intentionally Left Blank*

## CHAPTER 1: INTRODUCTION & RESEARCH APPROACH

---

### 1.1 INTRODUCTION & RESEARCH OBJECTIVES

#### 1.1.1 BACKGROUND

Scour is erosion of streambed or bank material caused by flowing water that may lead to failures around the piers and abutments of the bridge. In the United States of America, bridge scour is one of the three main causes of bridge failure along with collision and overloading failures. Scour countermeasures to prevent scouring around bridge substructure are an important parameter for bridge stability. Based on Hydraulic Engineering Circular No.23 (HEC-23)(1), a host of scour countermeasures matrix have been developed specifically for Pennsylvania bridges (special reference to PennDOT District 6-0 scour critical bridges) to address a specific type(s) of scour and to provide methodology/procedures for selecting and designing functional and cost-effective scour countermeasures (2). Currently in PennDOT District 6-0, the selection of appropriate countermeasures and the design for bridge foundation protection against scour have in general been limited in their applications to mainly dumped or hand-placed riprap, which can be displaced after major flood event. Partially grouted riprap (PGR) was one of the recommended scour countermeasures for PennDOT District 6-0. PGR is relatively new in the United States but has been used widely in Europe to prevent scour or erosion of the bed, banks, shoreline, and at piers and abutments.

HEC 23 Design Guidelines 12 “Partially Grouted Riprap at Bridge Piers” (1) provided general requirements for the design and construction of PGR in-the-wet and in-the-dry. The guidelines were based on guidance developed by Federal Waterway Engineering and Research Institute (BAW) in Germany (3, 4). Aside from these two sources, there is little guidance on the design and construction of PGR, hence, there is a critical need to develop guidelines to utilize PGR as a permanent countermeasure to control scour at bridge piers and abutments and to comply with US standards for the construction of PGR in-the-dry and in-the-wet.

In order to have an effective design guidelines for scour countermeasure at piers and abutments using PGR as a permanent countermeasure for scour control and remediation the developed draft guidelines should be tested on an existing scour critical bridge and modified accordingly. This project aimed to give PennDOT District 6-0 a better understanding of PGR as a scour countermeasure and how they can use PGR in the most effective ways to minimize environmental impacts, construction feasibility, and demonstrates strong cost benefit/low life cycle costs.

### 1.1.2 SCOPE OF WORK & PROBLEM STATEMENT

Partial grouting of riprap in Europe is often performed under water or in flowing water (5). Due to the concern for temporary water quality impacts during placement, this aspect may be a potential barrier to the acceptance and implementation of this technology in the US. Construction. Cost may increase substantially when water diversion and/or dewatering are required to install an effective countermeasure. Many sites cannot be economically dewatered during construction (6); therefore, the ability to place grout under water or in “live stream” conditions while maintaining water quality parameters within acceptable limits is of paramount importance (5, 7).

PGR consists of specific sized rocks that are placed around a pier or abutment on top of a filter layer, either a geotextile fabric or a filter layer of sand and/or gravel, specifically selected for compatibility with the subsoil, and "glued" together with grout (1, 8, 9, 10). PGR involves using Portland cement-based grouting to hold the riprap rocks together (11). The final configuration results in an armor layer that retains approximately one-half to two-thirds of the void space of the original riprap (1). The grouting considerably increases the hydraulic stability of the armor layer over that of loose riprap by the characteristics of the much larger mass and high degree of interlocking of the “conglomerate” particle (7). Grouting also decreases the likelihood of stone displacement that often occurs with loose riprap. In contrast to fully grouted riprap, partial grouting increases the overall stability of the riprap installation unit without sacrificing flexibility or permeability. It also allows for the use of smaller rock compared to standard riprap, resulting in decreased layer thickness.

The primary goal of this project was to develop design guidelines for scour countermeasure at piers and abutments using PGR in-the-dry and in-the-wet as a permanent countermeasure for scour control and remediation that minimizes environmental impacts, construction feasibility, and demonstrates strong cost benefit/low life cycle costs. With the direct assistance of the District 6-0 Technical Advisor, the guidelines for the design and construction of PGR in-the-dry and in-the-wet were to be developed in collaboration and advisement on the technical direction of the research project by Department of Environmental Protection (DEP) and the United States Army Corps of Engineers (COE). An existing scour critical bridge was to be selected by District 6-0 to implement the developed scour countermeasure guidelines using PGR. A monitoring system was to be utilized to determine the environmental impact on the stream before, during, and after construction. In addition, after a major flood or at least two NBIS Bridge Inspection cycles, an inspection was to be performed by District 6-0 at the PGR installation site to determine the performance and the needed maintenance of the constructed scour countermeasure, and to modify the developed design guidelines accordingly. To accomplish the objective of the research project, the following steps were proposed:

1. Develop design guidelines for PGR at bridge piers and abutments including special provisions to design and installation of PGR in-the-dry as well as placement in-the-wet

- (under water). The guidelines will include design, construction, inspection, maintenance, and performance specification.
2. Apply the developed design guidelines to protect one scour critical bridge in PennDOT District 6-0 that includes both dry and wet installation. In addition, develop best management practice for low cost and minimum environmental impact in regard to design, constructability, and erosion and sedimentation control.
  3. Construct PGR at the selected bridge in District 6-0 under General Permit BWEW-GP-11 (GP-11) permit by Designer in accordance with the developed guidelines in this research and evaluate the environmental impacts on the stream before, during, and after the construction of the scour countermeasure through monitoring of hydrologic and hydraulic conditions.
  4. Evaluate the performance of the as-built PGR scour countermeasure, perform cost analysis of the as-built countermeasure, and modify the design guidelines accordingly.

At the preapplication meeting for the recommended permit, the regulatory agencies, COE and DEP, rejected the General Permit BWEW-GP-11 for the proposed placement of PGR in-the-wet at the selected scour critical bridge in District 6-0. The COE and DEP requested that the permit application be evaluated under the highest level of permitting, Department of Army Individual Permit (IP). The COE also specifically required a 404(b)(1) Guideline Analysis, which includes rigorous purpose, need, and alternative analysis. When comparing BWEW-GP-11 to an IP permit, it became apparent that the IP permit required significantly more information, substantial preparation and time, and more construction details than BWEW-GP-11. Since IP Permit was not within the scope of the research project, it was decided to construct the PGR at the selected bridge in-the-dry under General Permit BWEW-GP-11. For more detail see Chapter 4.

Practical design guidelines for PGR in-the-dry as scour countermeasure at Piers and Abutments was presented in this research project for use by District 6-0 Bridge Unit as well as in the Commonwealth of Pennsylvania. The work done in this project, although performed for District 6-0 conditions, it should also be applicably applied throughout the state of Pennsylvania.

## 1.2 RESEARCH TASKS

### 1.2.1 TASK 1 – LITERATURE SEARCH

A comprehensive literature review was conducted to explore the most recent developments in scour countermeasures using PGR as a scour countermeasure. The research team used the most recent documentation from the state of Pennsylvania, surrounding states, national agencies, and international sources to compile a report that provided the current practices in the industry. Findings from the literature review on installation procedures and relevant water quality studies were intended to provide an overview rather than comprehensive descriptions.

## 1.2.2 TASK 2 – DEVELOPMENT OF BRIDGE SCOUR COUNTERMEASURE DESIGN GUIDELINES FOR PIERS AND ABUTMENTS USING PGR

Following the completion of the literature review in Task 1, a proposed outline for the design guidelines of PGR at bridge piers and abutments in-the-wet and in-the-dry was developed and was made available to PennDOT District 6-0 Technical Advisors and Technical Panel from DEP, U.S. Fish & Wildlife Service, and COE for review and comments. The design guidelines provided the technical approach, applicable standards and specifications for utilizing PGR as a scour countermeasure for PennDOT District 6-0 bridges. Based on the outcome of review and comments by the Technical Advisors and the Technical Panel, the final design guidelines of PGR at bridge piers and abutments was submitted to PennDOT District 6-0. The outlines of the design guidelines of PGR at bridge piers and abutments in-the-wet and in-the-dry included description of PGR, materials, design standards, construction specifications, water quality management, and measurement and payment.

## 1.2.3 TASK 3 – SELECTION OF ONE SCOUR CRITICAL BRIDGE IN PENNDOT DISTRICT 6-0

With the assistance of PennDOT District 6-0 Technical Advisor, an existing scour critical bridge BMS # 46202800200000 – Montgomery County, bridge SR 2028 (Camp Hill Road) over Sandy Run was selected to have PGR as a scour countermeasure to protect the structure from scour. When the available information for the selected bridge was reviewed, it was determined that a Hydrologic and Hydraulic (H&H) Analysis was required for the selected bridge to determine the scour countermeasure design parameters. The H&H Analysis for bridge SR 2028 was conducted in accordance with the design criteria provided in the Pennsylvania Department of Transportation's (PennDOT's) Publication 13M, Design Manual, Part 2, Highway Design, Chapter 10 (DM-2).

The H&H Analysis was performed to determine the flow velocity and peak discharge at the crossing of bridge SR 2028 and Sandy Run during various peak discharges. The information was then used to determine the impact of recurring floods on the bridge foundation and substructure, and to estimate the type and effects of scour at the bridge piers, bridge abutments and stream bed/banks so that the structural integrity of the bridge could be maintained. Further, obtained variables from H&H Analysis were utilized to evaluate the potential impacts to Sandy Run following the installation of a structural countermeasure along the bridge abutments and pier.

#### 1.2.4 TASK 4 – APPLICATION OF THE RESEARCH RESULTS TO DISTRICT 6 SELECTED BRIDGE - REVISED

Following the selection of an existing PennDOT District 6-0 scour critical bridge SR 2028, the final design guidelines of PGR at bridge piers and abutments in-the-wet and in-the-dry was utilized to develop recommendations for Plans, Specs, & Estimate package (PS&E). The preparation and support service for permitting were done only for Chapter 105 Water Obstruction and Encroachment Permit Under General Permit BWEW-GP-11 – Maintenance, for submittal to the Pennsylvania State Department of Environmental Protection (PADEP) by District 6-0.

The recommended PS&E package included:

- layout dimensions for PGR at piers and abutments for construction in-the-dry and in-the-wet.
- riprap size and mechanical and physical properties of riprap.
- grout requirements for construction in-the-wet and in-the-dry.
- filter requirements; Type Site and Location (TSL).
- construction plans; construction specification.
- engineering calculations and estimates.
- recommendation for E&S plan (erosion and sedimentation pollution control plan).
- recommendation for environmental documentation.
- recommendation for environmental monitoring before, during, and after construction.
- recommendations for environmental testing.

At the preapplication meeting for the recommended permit, the regulatory agencies, COE and DEP, rejected the General Permit BWEW-GP-11 for the proposed placement of PGR in-the-wet at the selected scour critical bridge in District 6-0. The COE and DEP requested that the permit application be evaluated under the highest level of permitting, Department of Army Individual Permit (IP). The COE also specifically required a 404(b)(1) Guideline Analysis, which includes rigorous purpose, need, and alternative analysis. When comparing BWEW-GP-11 to an IP permit, it became apparent that the IP permit required significantly more information, substantial preparation and time, and more construction details than BWEW-GP-11. Since IP Permit was not within the scope of the research project, it was decided to construct the PGR at the selected bridge in-the-dry under General Permit BWEW-GP-11.

The PS&E package and the General Permit BWEW-GP-11 for the construction of PGR in-the-dry at PennDOT District 6-0 scour critical bridge SR was prepared by Designer and submitted for approval

### 1.2.5 TASK 5 – CONSTRUCTION OF SCOUR COUNTERMEASURE AT THE SELECTED BRIDGE PIERS AND ABUTMENT USING PGR - REVISED

Upon the approval of General Permit BWEW-GP-11, PennDOT District 6-0 under Force Account selected a contractor to construct the PGR in-the-dry at the selected bridge.

Prior to the construction of PGR countermeasure at the selected scour critical bridge, the contractor conducted a demonstration of the various aspects of PGR for scour countermeasures at bridge piers and abutment for observation and ultimate approval by PennDOT's District 6-0 engineer. The demonstrated activities included grout design mix for dry application and the construction of a test-pit having the same thickness as the standard riprap section shown on the plan.

Water quality was monitored before, during, and after construction of PGR at bridge SR 2028 to determine the environmental impact of PGR construction on the river/stream. Water quality parameters monitored were pH, temperature, and turbidity. In addition, monitoring the construction of the scour countermeasure, especially during all grouting operation, was conducted throughout the construction to assure compliance with the developed guidelines for construction of PGR. Based on the construction process the design guidelines for PGR was modified accordingly.

### 1.2.6 TASK 6 – NBIS BRIDGE INSPECTION - REVISED

After the completion of the PGR construction at bridge SR 2028, the Temple research team conducted two on-site assessments to document the condition of the constructed PGR. The on-site assessment was visual, and the condition of the PGR was documented with underwater photos and video footage. A two-year cycle of NBIS Bridge Inspection was conducted at bridge SR 2028 to determine the performance and needed maintenance of the constructed PGR at bridge SR 2028.

### 1.2.7 TASK 7 – DRAFT FINAL REPORT

Upon completion of Task 1 through Task 6, a draft final report was generated that summarized all findings of the project and was presented to PennDOT Technical Panel for review. An Implementation Plan that provides detail on the broader use of the results of this project was included in the Draft Final Report for the PennDOT Technical Panel to review.

### 1.2.8 TASK 8 – FINAL REPORT

Task 8 report documents the entire research effort and included the final design guidelines of PGR at Piers and Abutments in-the-dry, Implementation Plan, and recommendations. Any comments provided by the technical advisory panel regarding the Draft Final Report were taken into consideration when generating the final report.

## 1.3 REPORT ORGANIZATION

The body of this report is divided into four main sections. The first section (Chapter 2), summarizes the bulk of the literature search done by the research team and encompasses the work done in Task 1. The second section (Chapter 3) presents the design guidelines for PGR at bridge piers and abutment in-the-dry and in-the-wet, and the application of PGR to the selected scour critical bridge SR 2028 in PennDOT District 6-0. This section encompasses the work done in Task 2 through Task 4. The third section (Chapter 4) provides the design and construction of PGR in-the-dry to the selected scour critical bridge SR 2028, assessment of the constructed PGR, and the revised design guidelines. This section encompasses the work done in Task 5 and 6. The last section (Chapter 5) provides the conclusion of the research, recommendation, and Implementation Plan.

## CHAPTER 2: LITERATURE RESEARCH FINDINGS

---

### 2.1 SCOUR AT BRIDGE CROSSINGS

Scour, in general, is the erosion of streambed or bank material caused by flowing water that may lead to failures around the piers and abutments of the bridge. Scour occurs at different rates for different materials (1). The rates of scour under different flow conditions depend on the erosive power of the flow velocity, the erosion resistance of the material, and the balance between sediment transported into and out of the bridge section. According to Hydraulic Engineering Circular No 18 (HEC-18) (12), bridge scour is comprised of three components: Long-term aggradations and degradation of the riverbed, Contraction scour, and Local scour. Scour can be deepest near the peak of a flood, but hardly visible as floodwater recede and scour holes are refilled with sediment (12). The National Bridge Inspection Standards (NBIS) (23 CFR 650, Subpart C) stipulates that bridge owners must uphold an inspection program. Potential scour must be monitored, inspected and repaired if needed. The term “scour critical” denotes an existing bridge which is currently unstable due to either (a) observed scour at a bridge site or (b) a scour potential as determined from a scour evaluation study (12). When a bridge is deemed scour critical, a risk-based analysis is necessary to develop an appropriate Plan Of Action (POA). In order to prioritize scour critical bridges, coding systems such as NBIS Item 113 (BMS2 Item 4A08) are used. These coding systems rate the bridges on factors such as substructure condition, importance of the structure, foundation type (if known), and span length etc. As a result, various scour critical bridges can be selected and repaired in order of priority. In the United States of America, bridge scour is the leading cause of bridge failure, followed by collision and overloading failures.

An armor layer to prevent scouring around a bridge substructure can improve bridge stability. The FHWA saw the need to identify common scour countermeasures and provide guidelines for their use. HEC-23 “Bridge Scour and Stream Instability Countermeasures: Experience, Selection, and Design Guidance” was published to provide guidance for scour countermeasure applicability, design, installation, and maintenance (1).

### 2.2 COUNTERMEASURE

Countermeasures are defined as measures incorporated into a highway-stream crossing system to monitor, control, inhibit, change, delay, or minimize stream instability and bridge scour problems (1). Countermeasures can be installed at the time of construction for new bridges or can be retrofitted to existing bridges when stability issues arise. It is crucial when selecting and designing countermeasures to take into account how the stream will respond.

Numerous measures are available to counteract the actions of humans and nature that contribute to the instability of alluvial streams. These include measures installed in or near the stream to protect highways and bridges by stabilizing a local reach of the stream, and erosion resistant mitigation measures that can be incorporated into the highway design to ensure the structural integrity of the highway in an unstable stream environment. Countermeasures include river-stabilizing works over a reach of the river upstream and downstream of the crossing. The selection, location, and design of countermeasures are dependent on hydraulic and geomorphic factors that contribute to stream instability, as well as costs and construction and maintenance considerations. The types of countermeasure considered include (1):

- Hydraulic Countermeasures
- Structural Countermeasures
- Biotechnical Countermeasures
- Monitoring

### 2.3 PARTIALLY GROUTED RIPRAP AS SCOUR COUNTERMEASURE

PGR as scour countermeasure (hydraulic countermeasure) is relatively new in the United States but has been used widely in Europe for several decades to prevent scour or erosion of the channel bed, banks, shoreline, and at piers and abutments (8, 10). Partial grouting in Europe is often performed under water, or in flowing water (5). Due to the concern for temporary water quality impacts during placement, this aspect may be a potential barrier to the acceptance and implementation of this technology in the US. Construction. Cost may increase substantially when water diversion and/or dewatering is required to install this countermeasure. Many sites cannot be economically dewatered during construction (5, 6); therefore, the ability to place grout under water or in “live stream” conditions while maintaining water quality parameters within acceptable limits is of paramount importance (5, 7).

PGR consists of specific sized rocks that are placed around a pier or abutment on top of a filter layer, either a geotextile fabric or a filter layer of sand and/or gravel, specifically selected for compatibility with the subsoil, and "glued" together with grout (1, 8, 9, 10, 13). PGR involves using Portland cement-based grouting to hold the riprap rocks together (8). The final configuration results in an armor layer that retains approximately one-half to two-thirds of the void space of the original riprap (1, 13). The grouting considerably increases the hydraulic stability of the armor layer over that of loose riprap by the characteristics of the much larger mass and high degree of interlocking of the “conglomerate” particle (7). Grouting also decreases the likelihood of rock displacement that often occurs with loose riprap. In contrast to fully grouted riprap, partial grouting increases the overall stability of the riprap installation unit without sacrificing flexibility or permeability. It also allows for the use of smaller rock compared to standard riprap, resulting in decreased layer thickness.

When PGR used for erosion protection is properly designed and constructed, it can provide long-term protection if it is inspected and maintained on a periodic basis as well as after flood events. PGR can easily be used in conjunction with biotechnical methods to minimize impact to any aquatic habitat and aesthetic that may be associated with loose (dumped or hand-placed) riprap (7, 10).

The success of PGR has been studied by numerous organizations, including Colorado State University (11) and Braunschweig University in Germany (3, 4), who is considered the leader in PGR technology (10). The latter determined that PGR could remain secure and unharmed in flows of 26 ft/s (11). Physical modeling performed by Colorado State University produced similar results, as loose riprap was damaged and displaced at flow velocities of 11 ft/s, while the grouted riprap remained intact (11).

Tests conducted under National Cooperative Highway Research Program (NCHRP) Report 593 "Countermeasures to Protect Bridge Piers from Scour" confirmed the applicability of PGR as a scour countermeasure for bridge piers (11). NCHRP Report 593 included investigation of PGR installations in Germany and laboratory investigations at Colorado State University at a prototype scale as the basis for developing guidelines applicable to U.S. practice for this technology. Although PGR has been used successfully for many applications in Europe, HEC-23 provides design guidelines specifically for PGR at bridge piers (1).

With PGR, there are no basic relationships for selecting the size of rock, other than the practical considerations of proper void size, gradation, and adequate stone-to-stone contact area (1, 11). The intent of partial grouting is to interlock the smaller riprap stones together to create "conglomerate particles" that resist higher flow velocities. Each conglomerate particle is therefore significantly larger than the  $d_{50}$  size of the individual stones, and typically is larger than the  $d_{100}$  size of the individual stones in the riprap matrix. The recommended gradation criteria are based on a nominal or "target"  $d_{50}$  and a uniformity ratio of  $d_{85}/d_{15}$  that results in riprap that is well, but not widely, graded (1, 11). Only stones with a  $d_{50}$  ranging from 9 inches to 15 inches should be used with the partial grouting technique (13). The target uniformity ratio is 2.0 and the allowable range is from 1.5 to 2.5 (1, 11). Riprap smaller than the designated gradation contains voids that are too small for the grout to effectively penetrate the required depth within the rock matrix. While rocks that are larger than the designated gradation have voids that are too large to retain the grout, and do not have enough contact area between the stones to effectively interlock them together (1, 11, 13).

HEC 23 Design Guidelines 12 "Partially Grouted Riprap at Bridge Piers" (1) provided general requirements for grouting materials. The requirements were based on guidance developed by Federal Waterway Engineering and Research Institute (BAW) in Germany (4, 14, 15). A basic grout mix design for one cubic yard of grout consists of ordinary Portland cement 740 to 760 pounds; fine concrete aggregate (sand) dry 1,180 to 1,200 pounds; ¼" crusher chips (very fine gravel) dry 1,180 to 1,200 pounds; water 420 to 459 pounds; air entrained 5 to 7 percent of cement; and anti-washout additive (used only for placement underwater) 6 to 8 pounds (13). The mix should result

in a wet grout density ranging from 120 to 140 lb/ft<sup>3</sup>. Wet densities outside this range should be rejected and the mix should be re-evaluated for material properties of the individual constituents. Standardized concrete testing procedures from European practice (tap test) are used to check grout quality and consistency (13). Recommended grouting material quantities are for  $d_{50} = 9$  inch, 2.0 - 2.2 ft<sup>3</sup>/yd<sup>2</sup>; for  $d_{50} = 12$  inch, 2.7 - 3.2 ft<sup>3</sup>/yd<sup>2</sup>; for  $d_{50} = 15$  inch, 3.4 - 4.1 ft<sup>3</sup>/yd<sup>2</sup> (13, 11). When riprap is positioned loosely (e.g., dumped or hand-placed stone), the application quantity should be increased by 15 to 25%. When stones are tightly packed (e.g., compacted or plated riprap) the application quantity should be decreased by 10% (1, 5).

With the proper grout mix, partial grouting can be done underwater (5, 7). Special devices are required for placement in deeper water. Various European countries have developed special grout mixes and construction methods for underwater installation of PGR (1, 3, 4, 7, 13). An appropriate grout pattern is obtained when the grout is placed on the riprap leaving significant voids in the riprap matrix and considerable open space on the surface. To prevent clogging of the filter layer, no grout should penetrate deep enough to come in contact with any underlying filter (1, 10). The target distribution of grout within the riprap matrix is such that about 2/3 of the grout should reside in the upper half of the riprap layer, with 1/3 of the grout penetrating into the lower half (1, 7, 10, 13). Construction methods must be closely monitored to ensure that the appropriate voids and surface openings are provided. Contractors in Germany have developed techniques and special equipment to achieve the desired grout coverage and the correct grout penetration (5, 7).

Partial grouting of riprap can cause slight environmental issues that may be of greater concern during construction in-the-dry than in-the-wet. PGR construction in-the-dry requires dewatering that has a great impact on water quality and biological conditions, and it takes longer to install than installation in-the-wet. For PGR constructions in-the-wet, turbidity and pH changes are the main concerns (1, 16). Monitoring of turbidity is necessary and use of an anti-washout additive to reduce the separation of fines and cement can reduce the pH level (5).

A comprehensive study conducted by the Virginia Transportation Research Council of 31 field sites combined with a supplemental laboratory component investigated the effects of various placement methods on various water quality parameters potentially affected by underwater grouting (16). At eleven of these sites, grout was placed underwater by using grout pumped through a series of hoses and into a steel tremie pipe. The tremie pipe extended through geotextile fabric under the structure and into the void being filled. The geotextile fabric served as a boundary to prevent the grout from coming out of the void while allowing the water being displaced by the grout to exit the void. The remaining sites were repaired by pumping grout into grout bags. The techniques required to maintain water quality within acceptable limits were found to depend primarily on the dimensionless dilution ratio (stream discharge rate divided by grout application rate) (16). In that study, a dilution ratio greater than 40:1 (streamflow to grout) was found in general to be sufficient to keep pH levels below 9.0. The use of anti-washout additives and the placement of a grout curtain (turbidity curtain) around the work area were found to further reduce the impact on water quality (16). Based on research performed by the Virginia DOT (16), pH was the only water quality parameter that was expected to change significantly during

grout placement (16). In the VDOT study, permit conditions required that pH levels remain below a value of 9.0 at a distance of 33 ft downstream of placement, otherwise, grouting activities were to be stopped, and mitigation measures such as silt curtains were to be employed (16). VDOT did not monitor turbidity during their study.

During full scale testing of a simulated bridge pier at Colorado State University (11), water quality monitoring was performed. Water quality was monitored before, during, and after the grout placement. Water quality parameters monitored continuously were pH, electro-conductivity, temperature, and turbidity. Continuous water quality data was calibrated to background data collected at various stations prior to grout placement. Background pH was 6.9 to 7.0 at all stations located in the flume itself. In addition to the continuous monitoring probes, grab samples were selected for analysis corresponding to a baseline sample taken when testing commenced. The grab samples were analyzed for selected inorganic and metals. A spike in pH was observed at the locations directly downstream of the pier during grout pumping. At a station 12 ft directly downstream of pier, a maximum pH of 9.9 was recorded three minutes after pumping began (7, 11). After grout pumping was completed, pH values normalized quickly and returned to baseline conditions within about 30 minutes. The one exception was the probe at a station located 12 ft directly in the wake of the pier. At this location, the pH returned to background levels after about 4 hours. At a station located 24 ft directly downstream from the pier, a much less pronounced pH profile and more rapid decay of concentration was recorded (pH 9.5).

A host of scour countermeasures matrix have been developed specifically for Pennsylvania bridges (special reference to District 6-0 scour critical bridges) to address a specific type(s) of scour and to provide methodology/procedures for selecting and designing functional and cost-effective scour countermeasures (2). PGR was one of the recommended countermeasures for Pennsylvania. Standard construction detail drawings were developed for new and existing bridges using PGR (2).

A limited number of sites in the US have utilized PGR as a scour countermeasure. All PGR placement used grouting in-the-dry where dewatering during construction was possible. The Minnesota Department of Transportation (MnDOT) (17) has identified Matrix Riprap (PGR in HEC-23 (1)) as a countermeasure to provide erosion resistance for minimizing scour and erosion in open channel flow. MnDOT performed a demonstration application of Matrix Riprap installation in the dry as a scour countermeasure at abutments of an existing bridge in MnDOT District 3. The bridge abutments had existing riprap of a size suited for Matrix Riprap application. For monitoring performance over time, MnDOT applied the Matrix Riprap treatment to only one of the two abutments (17). The existing riprap at the abutment was rounded, whereas ideally the riprap should be angular to sub-angular. Further, in some areas the rock gradation was uniform. In other areas, some very large rocks were surrounded with much smaller rocks that led to small-sized voids. Additionally, sediment and soil had washed into the voids of the original riprap in a few areas, thus decreasing the amount of open void area available for grout penetration such that, grout only puddled on the surface. Subsequent to the installation of the Matrix Riprap, seven grout mix designs without anti-wash additive for construction in the dry were batched and tested at Colorado State University (17). The flow ability of each batch was tested using standard American

test equipment and compared to the results from the European Flow Table “TAP” test, which was used as the standard QA/QC test for the grout component of Matrix Riprap. Of all the standard American devices investigated, the results from the American slump cone test (ASTM C143) exhibited the best correlation to the European Flow Table results (1, 13). The partial grouting of the matrix riprap was delivered by a grout pump. The pump delivered the grout in pulses with each pulse delivering a large volume of grout in a short period of time (2-3 seconds). The rate of grout delivery was too great for accurate placement of the grout, resulting in excessive splash on the surface of the stones.

In 2011, New Hampshire Department of Transportation (NH DOT) utilized PGR as a scour countermeasure at “Holderness Bridge No. 109/109” (single span concrete slab bridge) placed in the dry (18). HEC 23 Design Guide 12 (1) was applied to the Holderness bridge abutments. It demonstrated that construction in-the-dry requires water diversions and dewatering. These operations can have severe impact on the environment. In addition, a costly process required a phased approach. The site was inspected after two years, and no adverse effects were observed upstream or downstream. In addition, the streambed was uniform on both sides and no scour holes were observed.

The available information in the literature demonstrates that although Pennsylvania’s practices with scour countermeasures have been successful to this point, there is still an opportunity to expand PennDOT’s practices by using PGR. Such technology of scour countermeasures may demonstrate to be more successful, easily installed with less effort to maintain, and more economical in many locations than the current practices.

# CHAPTER 3: DRAFT DESIGN GUIDELINES OF PGR AT BRIDGE PIERS AND ABUTMENTS IN-THE-DRY AND IN-THE-WET, AND APPLICATION OF PGR TO SCOUR CRITICAL BRIDGE IN PENNDOT DISTRICT 6-0

---

## 3.1 DRAFT DESIGN GUIDELINES OF PGR AT BRIDGE PIERS AND ABUTMENTS IN-THE-DRY AND IN-THE-WET

Draft design guidelines of PGR at bridge piers and abutments in-the-dry and in-the-wet were submitted to the Technical Advisors (PennDOT District 6-0) and the Technical Panel (regulatory agencies) for review and comments. Based on their feedback and comments the design guidelines were modified. The draft design guidelines provided the technical approach, applicable standards, and specifications for utilizing PGR as a scour countermeasure for bridges in PennDOT District 6-0 and the State of Pennsylvania. The draft design guidelines included a description of PGR, materials, design standards, construction specifications, water quality management, and measurement and payment.

### 3.1.1 DESCRIPTION

This work consists of constructing PGR scour countermeasures around bridge piers and abutments in-the-dry or underwater in-the-wet conditions in accordance with PennDOT Standard Specification Publication 408.

PGR construction involves furnishing and placing rock riprap at designated locations shown in the contract drawings and specifications, and project special provisions. The riprap is placed on top of a filter layer consisting of a geotextile fabric and a granular material. The voids of the riprap are then partially filled with a Portland cement-based grout by hose or tremie placement technique. The final configuration results in a partially grouted layer that retains approximately one-half to two-thirds of the void space of the original placement configuration.

### 3.1.2 MATERIALS

All materials shall satisfy the requirements of the designated PennDOT Specification (Publication 408) and are listed in PennDOT Bulletins 14, 15, and 42.

### 3.1.2.1 ROCK

The Contractor shall furnish only rocks that meet the requirements of Class Size No “R-6” of Section 850 “Rock Lining” or any of the modified Class Size No R-5M, R-6M, and R-7M that meets the rocks size and gradation shown in Table 1. All rocks in the modified rock sizes shall conform to the requirement of Section 850.2 (a) 1. See Appendix A for further detailed information on rocks. The Class Size No of riprap required shall be as shown in the contract drawings and specification, and project special provisions.

<b>Table 1: Size and Gradation of the Modified Class Size No</b>			
	Percent Passing (Square Openings)		
Modified Class Size No.	R-7M	R-6M	R-5M
Rock Size, millimeters (inches)			
1070 (42)			
760 (30)	100*		
610 (24)		100*	
460 (18)	65-85		100*
380 (15)	35-55	65-85	
300 (12)	5-15	35-55	65-85
230 (9)			35-55
150 (6)		5-15	5-15
100 (4)			
75 (3)			
50 (2)			
Nominal Placement Thickness, millimeters (inches)	915 (36)	800 (30)	610 (24)

\* Maximum allowable rock size

### 3.1.2.2 GROUT

The Contractor shall furnish Portland cement base concrete with grout mix design that meets the requirements of Section 2.2.1 “Grout Mix”. Use the following materials:

- a. Cement – Type I or Type II, Section 701
- b. Fine Aggregate – Type A, Section 703.1
- c. Coarse Aggregate – AASHTO Number 8, Section 703.2
- d. Water – Section 720.1
- e. Air Entraining Admixture –Section 711.3(d)
- f. Water-Reducing Admixture – Section 711.3(f)
- g. Anti-washout Admixture – Section 711.3(f)

### 3.1.2.2.1 GROUT MIX

The contractor will be required to submit grout mix results from a certified material testing laboratory for review and approval. The grout mix must comply with design parameters in Table 2 and the material testing requirements of this section. See Appendix B for further detailed information on grout mix. Construction shall not commence prior to the approval of grout mix.

<b>Table 2: Target Grout Mix Design</b>	
Material	Quantity by weight for one cubic yard of grout, pounds
Portland cement, Type I or Type II	740 to 760
Fine Aggregate, dry	1,180 to 1,200
¼" crusher chips or AASHTO No. 8 (coarse aggregate), dry	1,180 to 1,200
Water-Cement Ratio (w/c)	0.40 to 0.45
Air entrained Admixture	Manufacturer Recommendation
Water-Reducing Admixture	Manufacturer Recommendation
Anti-washout Admixture (AWA) (used only for placement underwater)	Manufacturer Recommendation

- The targeted grout mix should result in a wet grout density ranging from 120 to 140 lb/ft<sup>3</sup>. Wet densities outside this range shall be rejected and the mix re-evaluated for material properties of the individual constituents.
- The targeted grout mix shall result a minimum air content of 6% in the plastic state.
- For placement in-the-wet the contractor will be required to submit results from the US Army Corp of Engineers (ACOE) CRD\_C 61 – 89A Test Method for Determining the Resistancy of Freshly Mixed Concrete to Washing Out in Water”. The Grout mix should result in a maximum permissible mass loss of grout materials of 6%.

- Spread Test – Using ASTM C 1611 “Standard Test Method for Slump of Self-Consolidating Concrete” Procedure B, referenced as “Spread-Test”, is used to evaluate grout quality and consistency. The target values for the Spread-Test measurements are presented in the Table 3.

<b>Table 3: Grout Diameter During Spread Test</b>	
For placement in-the-dry	15.0 to 18.0 inch
For placement in-the-wet	12.0 to 15.0 inch

### 3.1.2.2.2 FIELD QUALITY ASSURANCE REQUIREMENTS

Conduct a consistency test on the grout mix using ASTM C 1611 “Standard Test Method for Slump of Self-Consolidating Concrete” Procedure B, referenced as “Spread-Test.” The “Spread-Test” shall be performed a minimum of two times per batch. The consistency test shall be completed once at the beginning of the grout mix and once at approximately halfway of the grouting operations.

### 3.1.2.2.3 CONSISTENCY “SPREAD-TEST” REQUIREMENTS

- Upon arrival at the site, add the required admixtures per material specification and mix for five minutes. Discharge a small sample into wheelbarrows for testing.
- Perform an initial “Spread-Test” as specified in ASTM C 1611, Procedure B. Record the average measurement in the orthogonal direction and compare with the grout mix requirement of Table 3 above. The Engineer shall verify that the grout mix complies with the required parameters.
- Add additional water if indicated, remix for five minutes, and retest.
- If the tested grout does not meet the spread limit requirements of Table 3, add more water, remix for an additional five minutes, and retest.
- The Engineer shall not approve the grout mix if the total elapsed time since the initial batching exceeds 100 minutes.
- Grout that meets the spread test and elapsed time requirements shall be considered approved and can be used for partially grouting the riprap.

### 3.1.2.3 COMBINED GEOTEXTILE AND GRANULAR FILTER

Use 6-inch layer of AASHTO Number 57 Type A coarse aggregate that meet the requirements of Section 703.2 on top of Geotextiles - Class 4, Type A non-woven geotextiles, as specified in Sections 735, 212.2 and 212.3(d).

### 3.1.3 TURBIDITY CURTAIN

The Contractor shall furnish, construct, install, maintain, and remove a commercially available and pre-assembled turbidity curtain to minimize dispersion of sediment/suspended particles and minimize pH level increase outside the turbidity curtain during the construction of PGR in-the-wet. The selected turbidity curtain must conform to the site-specific conditions and be stable. Additional measures to reduce stream flow velocity and to stabilize the turbidity curtain, such as energy dissipation mechanisms, can be used in conjunction with the turbidity curtain to provide effective containment of the turbidity curtain that is a bridge site specific characteristic. The turbidity curtain must contain non-corroded elements and includes geotextile, floatation system, bottom weight, and anchoring and securing system. Prior to the installation of the turbidity curtain and its accessories, or any additional measures to provide an effective containment of the turbidity curtain, the Contractor shall submit the manufacturer's drawing and technical specification to the Engineer for approval. The construction of the turbidity curtain and any additional measures shall be as shown on the Plans, and as directed by the manufacturer and the Engineer.

The curtain shall be made of a synthetic material coated with suitable elastomeric or polymeric compound and have a high resistance to weathering, hydrocarbons, fresh and saltwater, and temperature extremes. The material shall meet the requirements of Table 4

Minimum Strength Class Requirements				Turbidity Class requirements		
Percent Elongation, %	Grab Strength, lbf	Tear Strength, lbf	Puncture Strength, lbf	Apparent Opening Size (Maximum)		Minimum Permittivity, sec <sup>-1</sup>
				Sieve Size, inch	Sieve Designation	
<50	247	90 <sup>1</sup>	495	0.0117	No. 50	0.4
≥50	157	56	309			

<sup>1</sup> For woven monofilament geotextiles the minimum average value is 56 lbf

Hemmed pockets shall be sewn/or heat bonded to contain flotation material, bottom weights, and anchor lines. The flotation material shall maintain buoyancy if punctured or cut. Flotation units shall be flexible, buoyant units contained in a flotation sleeve or collar attached to the turbidity curtain. Buoyancy provided by the flotation units shall be adequate to support the

required width of the turbidity curtain and maintain a freeboard of at least 4-inches above the water surface level to prohibit escape of turbid water over the top. The bottom weight shall be adequate to hold the curtain in a vertical position. For sites not subject to tidal or heavy wave action, the curtain shall be capable of molding to conform to bottom contours so that suspended sediment is prevented from escaping underneath the curtain.

Anchorage lines shall be provided of minimum breaking strength of 10,000 lbf and sufficient number of anchor lines to support the curtain and maintain it in position under normally expected conditions. The size, weight, and overall number of the anchors shall be adequate to hold the turbidity curtain in its intended location, and the anchoring details for the site-specific conditions shall be included on the design plans. Where the turbidity curtain is constructed in panels, anchor-line and shackle connections securing the panels together shall be adequate for normally expected current and wind conditions.

The curtain height shall provide adequate slack to allow the top of the curtain to rise to the maximum expected high-water level (including waves), while the bottom maintains continuous contact with the bottom of the water body. The bottom edge of the curtain shall have a weight system capable of holding the bottom of the curtain down and conforming to the water body, to prohibit escape of turbid water under the curtain.

For a turbidity curtain constructed in panels, the panels shall be connected in such a manner as to prevent suspended particles passing through joints. Load lines shall be connected to develop the full strength of the line across the joint

### 3.1.4 DESIGN STANDARDS

#### 3.1.4.1 LAYOUT DIMENSIONS

##### 3.1.4.1.1 PIERS

The PGR shall be installed to the limits and details indicated on the design plans. Sample plans showing PGR layout/dimensions and details for protecting existing piers are presented in Figure 1. In general, the final elevation of PGR countermeasure at the upstream and downstream placement limits shall be flush/blended with the natural riverbed material.

##### 3.1.4.1.2 ABUTMENTS

The PGR shall be installed to the limits and details indicated on the design plans. Sample plans showing PGR layout/dimensions and details for protecting existing abutments are presented in Figure 2. In general, the final elevation of PGR countermeasure at the upstream and downstream placement limits shall be flush/blended with the natural riverbed material.

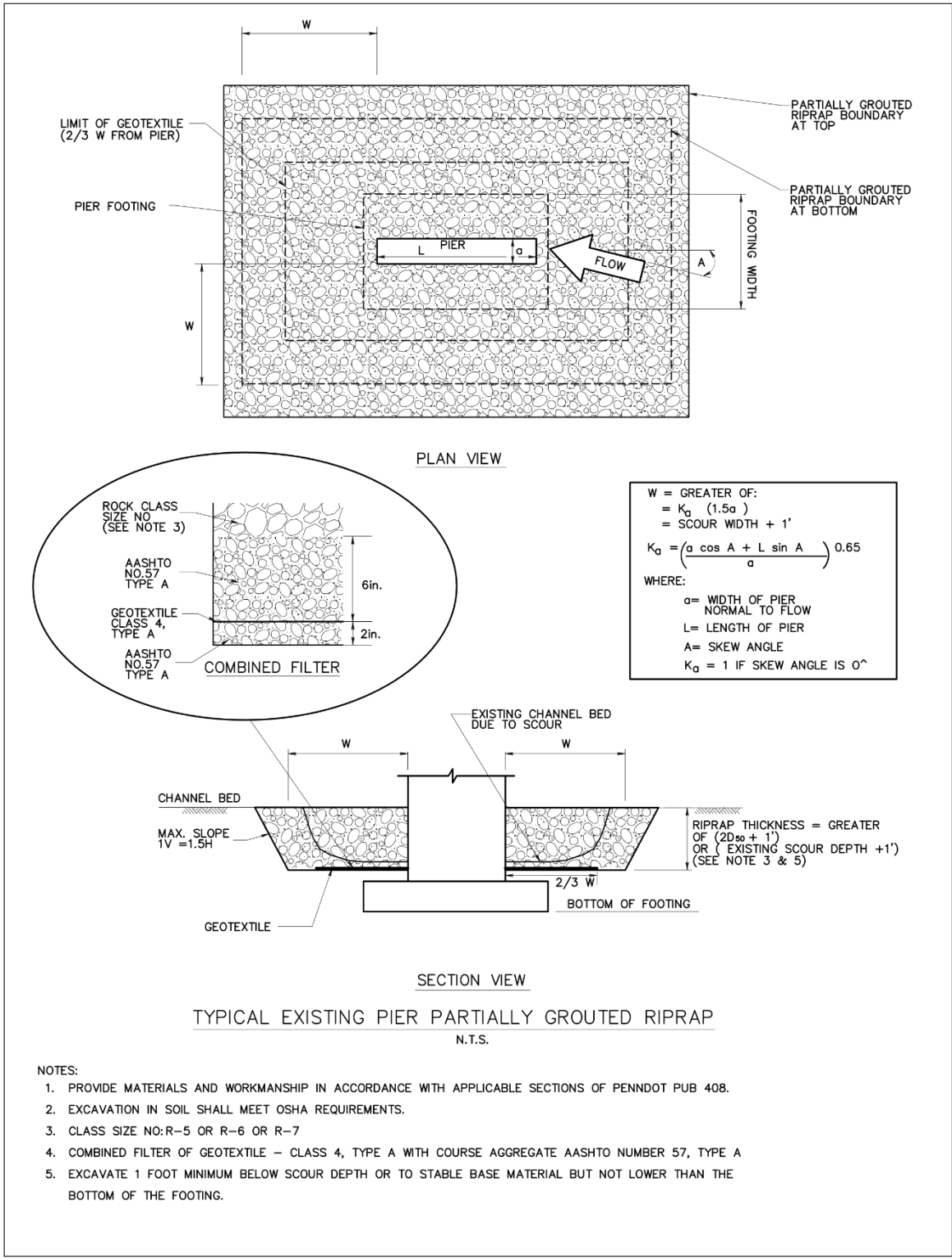

**Figure 1 Existing Pier PGR Layout Dimensions**

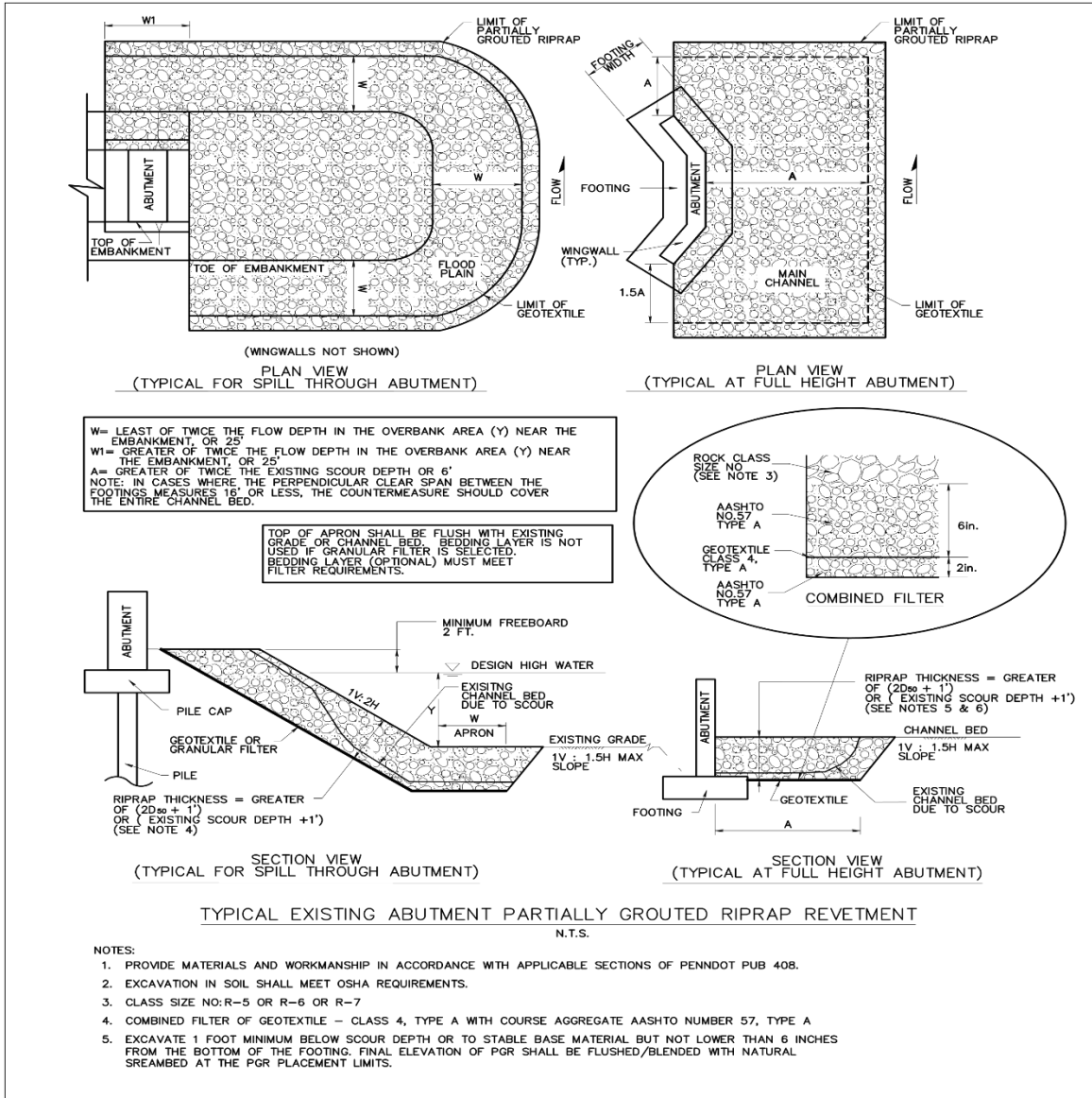

**Figure 2 Existing Abutment PGR Layout Dimensions**

### 3.1.5 CONSTRUCTION SPECIFICATIONS

#### 3.1.5.1 GENERAL

PGR should be installed in a pre-excavated area such that the top surface elevation of the final installation is level with the natural geometry of the streambed. The original excavated material shall be used to maintain the streambed grade and shall be blended to meet the natural bed materials at the upstream and downstream placement limits. Excavation limits are defined on the design plans and described in Section 3.1.5.3.

The edges of the PGR installation shall be toed into the streambed (deeper) as shown on the design plans and blended to match/meet the existing streambed. Grouting along the immediate interface of the piers or abutments shall be in accordance with the design plans.

Handling and transportation of filter and riprap materials shall minimize segregation of the materials and shall be in accordance with PennDOT standards.

Grout delivered to the site for installation of PGR in-the-wet shall be limited to two cubic yards per truck unless approved by the Engineer.

Following acceptance of the grouting procedure, the area along the perimeter toe of the installation shall be backfilled with native streambed material from the initial excavation.

A phased approach may be recommended at a site to minimize costs and reduce impacts on stream flow management. Additional details will be included in the design plans as needed.

#### 3.1.5.2 CONTRACTOR REQUIREMENTS

The Contractor shall comply with the following:

- Strict adherence to environmental protection and permit restrictions, regardless of whether the installation shall be performed in-the-dry or in-the-wet by underwater grouting.
- Careful attention to the strict requirements of the grout mix design that includes several admixtures, and potential refinement in the field prior to grout acceptance and placement.
- The Contractor shall comply with Section 3.1.2.2.1 Grout Mix.
- Willingness and ability to work cooperatively with others beyond the normal construction inspector expectations, which may include other representatives of PennDOT, PADEP, COE, and Engineers.

The Contractor shall conduct a demonstration of the various aspects of this work for observation and ultimate approval by the Engineer. The demonstration activities shall include the following, at a minimum:

- Development of grout mixes (lab results) – dry application and underwater application in accordance with section 3.1.2.2.1
- Upon approval of the grout mix, the contractor shall conduct a demonstration in accordance with the “PGR Mock-up Training Test Pit Set Up” shown in Figure 3 for observation and the Engineer’s approval. The test pit shall be the same thickness as the standard riprap section plus allowance for an additional one foot “water column” atop the riprap for grout placement in-the-wet.
- Line the test pit with plastic sheets (2 layers of “poly”) that have a minimum thickness of 6mil per layer.
- Fill the test pit with riprap to the same thickness as the standard riprap section and grout. For placement in-the-wet fill the test pit with the riprap and water and grout in-the-wet
- For placement in-the-wet and after 24 hours, drain the test pit to allow inspection to confirm that the proper grout coverage and penetration depths have been achieved.
- Once approved, the same method/application used in the test pit shall be reproduced for the PGR project installation at the bridge site.

### 3.1.5.3 EXCAVATION

#### 3.1.5.3.1 GENERAL

Prior to any streambed excavation, the existing riverbed and bank geometry shall be documented, with focus on the existing streambed elevations upstream and downstream of the proposed limits of the PGR installation. Excavation limits shall follow the design plans and meet PennDOT standards.

#### 3.1.5.3.2 EXCAVATION IN-THE-DRY

The Contractor shall perform all work in a dewatered and dry environment. The Contractor shall prepare the area required for the full cross section of PGR as indicated in the design plans while providing a low flow channel. This preparation may include, but is not limited to, excavating,

removing unsuitable material, backfilling, clearing and grubbing as specified in Section 201.3. Stockpile excavated streambed material to backfill the PGR installation.

#### 3.1.5.3.3 EXCAVATION IN-THE-WET

The Contractor shall perform all work in-the-wet and wet environment. The Contractor shall prepare the area required for the full cross section of PGR as indicated in the design plans while providing a low flow channel. This preparation may include, but is not limited to, excavating, removing unsuitable material, backfilling, clearing and grubbing as specified in Section 201.3.

#### 3.1.5.4 COMBINED FILTER PLACEMENT

##### 3.1.5.4.1 GENERAL

Regardless of whether the filter is installed in-the-dry or in-the-wet, the granular filter must be placed onto the geotextile carefully to avoid voids, gaps, tears, or holes in the geotextile. If any damages are observed, the geotextile must be either repaired or replaced.

##### 3.1.5.4.2 IN-THE-DRY

The Contractor shall place an approximate 2-inch layer of AASHTO Number 57 Type coarse aggregate, as specified in Section 703.2, on top of the subgrade to level the subgrade base. On top of the approximate 2-inch layer of AASHTO Number 57 Type coarse aggregate, the Contractor shall place geotextile Class 4, Type A non-woven geotextiles, as specified in Sections 735, 212.2 and 212.3(d). The Contractor shall then carefully place 6-inch of No. 57 Coarse Aggregate, Type A, on the geotextile to avoid voids, gaps, tears or holes in the geotextiles as shown on the design plans. If any damages are observed, the geotextile must be either repaired or replaced.

##### 3.1.5.4.3 IN-THE-WET

For underwater granular filter placement around bridge piers and abutments, it is recommended that tremie hose can be used to control the placement location, thickness, and minimize the potential for segregation of the granular filter. The Contractor shall place an approximate 2-inch layer of AASHTO Number 57 Type coarse aggregate, as specified in Section 703.2, on top of the subgrade to level subgrade base. On top of the approximate 2-inch layer of AASHTO Number 57 Type coarse aggregate, the Contractor shall place geotextile Class 4, Type A non-woven geotextiles, as specified in Sections 735, 212.2 and 212.3(d). Finally, the Contractor shall carefully place 6-inch of No. 57 Coarse Aggregate, Type A, on the geotextile to avoid voids, gaps, tears or holes in the geotextiles as shown on the design plans. If any damages are observed, the geotextile must be either repaired or replaced.

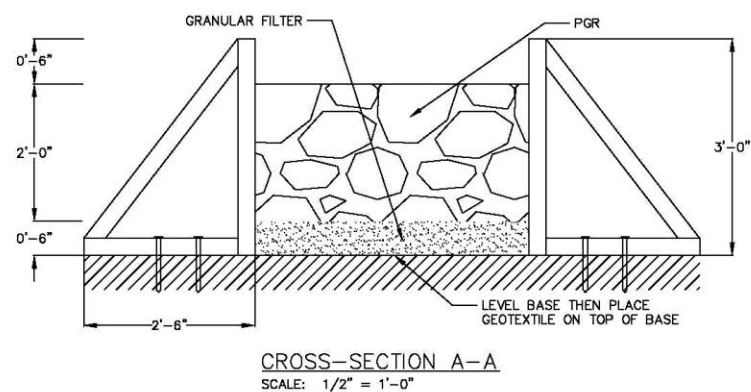
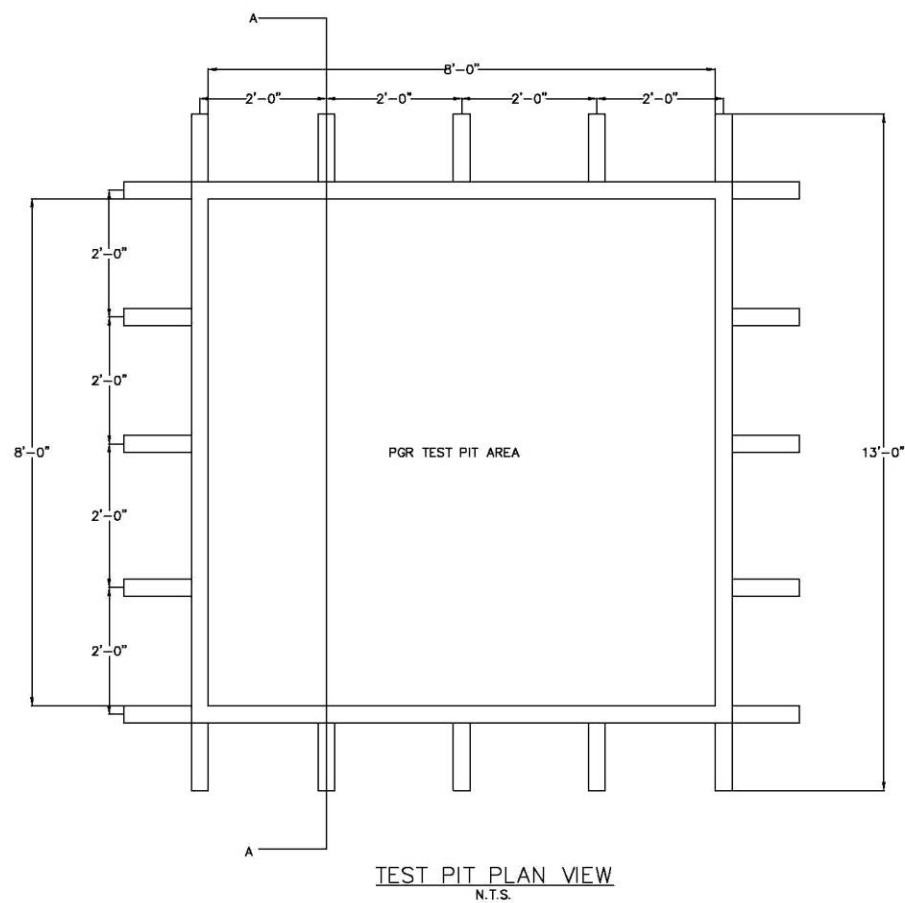

**PGR CONSTRUCTION IN THE DRY MOCK-UP TRAINING PROTOCOL FOR SR 2026 PROJECT:**

1. CREATE A TEST PIT OF AN AREA OF 8'-0" X 8'-0" AS SHOWN IN PLANS.
2. CONSTRUCT FORM WITH A DEPTH OF 3'-0" AS SHOWN IN CROSS-SECTION A-A.
3. PLACE CLASS 4, TYPE A NON-WOVEN GEOTEXTILE MATERIAL ON A LEVEL BASE AT THE BOTTOM OF THE TEST PIT. GEOTEXTILE CLASS 4, TYPE A MUST MEET PENNDOT SPECIFICATIONS, SECTION 735.1 AND 735.1 (b).
4. PLACE 0'-6" LAYER OF GRANULAR FILTER, AASHTO NUMBER 57 TYPE A OR BETTER, ON TOP OF THE GEOTEXTILE MATERIAL. GRANULAR FILTER AASHTO NUMBER 57 TYPE A MUST MEET THE REQUIREMENTS OF PENNDOT SPECIFICATIONS, SECTION 703.2.
  - 4.a. THE GRANULAR FILTER MUST BE PLACED ONTO THE GEOTEXTILE CAREFULLY TO PREVENT VOIDS, GAPS, TEARS, AND/OR HOLES IN THE GEOTEXTILE.
  - 4.b. IF ANY DAMAGES ARE OBSERVED, THE GEOTEXTILE MUST BE EITHER REPAIRED OR REPLACED.
  - 4.c. THE CONTRACTOR SHALL MEET THE REQUIREMENTS OF PENNDOT STANDARDS FOR FILTER PLACEMENT IN THE DRY.
5. PRESSURE WASH CLASS R-6 ROCKS PRIOR TO PLACEMENT IN THE TEST PIT. THE ROCKS SHALL BE FREE OF SILT OR ANY OTHER DEBRIS ACCORDING TO THE DESIGN PLANS. CREEK WATER IS ACCEPTABLE FOR WASHING AS LONG AS IT IS CLEAN WATER.
6. PLACE CLASS R-6 ROCKS CONFORMING TO REQUIREMENTS SPECIFIED IN SECTION 850.2(a) 1 AND 850.2(a) 2 AND TO HAVE A DEPTH OF 2'-0". THE THICKNESS OF THE RIPRAP LAYER SHALL BE PLACED WITH A TOLERANCE OF +/- 10% OR AS APPROVED BY THE ENGINEER.
7. PARTIALLY GROUT THE VOID SPACES WITHIN THE RIPRAP USING THE ZIG-ZAG PARTIALLY GROUT TECHNIQUE, IN ORDER TO FILL APPROXIMATELY 1/3 TO 1/2 THE VOID SPACES.
  - 7.a. REFER TO THE TABLE BELOW FOR THE GROUT MIX DESIGN FOR ONE CUBIC YARD.
  - 7.b. THE TARGETED GROUT MIX SHOULD RESULT IN A WET GROUT DENSITY RANGING FROM 120 TO 140 LB/FT<sup>3</sup>. WET DENSITIES OUTSIDE THIS RANGE SHALL BE REJECTED AND THE MIX RE-EVALUATED FOR MATERIAL PROPERTIES OF THE INDIVIDUAL CONSTITUENTS.
  - 7.c. THE TARGETED GROUT MIX SHALL RESULT A MINIMUM AIR CONTENT OF 6% THE TARGETED GROUT MIX SHALL RESULT A MINIMUM AIR CONTENT OF 6% IN THE PLASTIC STATE.
  - 7.d. THE GROUT MUST HAVE A COMPRESSIVE STRENGTH OF 2500 PSI.
  - 7.e. ASTM C 1611 "STANDARD TEST METHOD FOR SLUMP OF SELF-CONSOLIDATING CONCRETE," PROCEDURE B (SPREAD TEST) MUST BE PERFORMED TO EVALUATE GROUT QUALITY AND CONSISTENCY. THE TARGET VALUE FOR THE GROUT DIAMETER DURING THE 'SPREAD TEST' FOR GROUT PLACEMENT IN THE DRY IS 15" TO 18".
  - 7.f. THE AMOUNT OF GROUT TO BE INSTALLED IS DEPENDENT ON THE CLASS OF ROCKS USED. SINCE CLASS R-6 ROCKS IS BEING USED FOR THIS PROJECT, 2.7 TO 3.2 CUBIC FEET/SQUARE YARD SHOULD BE APPLIED.
8. REMOVE FORMS TO EVALUATE THE GROUT PLACEMENT.

**EQUIPMENT:**

1. SMALL BACKHOE.
2. GROUT PUMP WITH DELIVERY HOSE DIAMETER BETWEEN 1.5" TO 2", HAVE AN ADJUSTABLE FLOW CONTROL, HAVE 20 TO 30' OF HOSE, AND ABILITY TO HANDLE 3/8" DIAMETER AGGREGATE. GROUT PUMP UTILIZED MUST REPLICATE THE GROUT PUMP THAT WILL BE USED FOR FIELD PLACEMENT.
4. CONCRETE TRUCK
5. WATER SUPPLY OR WATER TRUCK
6. WHEEL BARROW FOR TESTING THE CONSISTENCY OF THE GROUT

**MATERIAL:**

1. CLASS 4, TYPE A NON-WOVEN GEOTEXTILE
2. AASHTO NUMBER 57, TYPE A GRANULAR FILTER
3. CLASS R-6 ROCKS
4. GROUT MIX MATERIALS
5. FORMWORK AS NEEDED

GROUT MIX DESIGN FOR ONE CUBIC YARD	
MATERIAL	QUANTITY BY WEIGHT FOR ONE CUBIC YARD OF GROUT, LB
PORTLAND CEMENT, TYPE I OR TYPE II	740 - 760
TABLE A, SECTION 703.1, FINE AGGREGATE, DRY	1,180 - 1,200
AASHTO NO. 8, TABLE C SECTION 703.2 Coarse Aggregate, MUST BE WASHED	1,180 - 1,200
WATER-CEMENT RATIO (w/c)	0.40 - 0.45
AIR ENTRAINED ADMIXTURE	MANUFACTURER RECOMMENDATION
WATER-REDUCING ADMIXTURE	MANUFACTURER RECOMMENDATION

SHEET NUMBER:	TEM-001
SHEET TITLE:	PGR MOCK-UP TRAINING TEST-PIT

Figure 3 PGR Mock-UP Training Test-Pit

The following steps should be taken when laying a geotextile filter underwater:

- Submerge the roll of geotextile material atop the riverbed.
- Weigh down the leading edge of the geotextile with sandbags or loose stones to keep the geotextile in place while it is unrolled.
- The geotextile should be unrolled in the direction of the flow and weighed down at frequent intervals to ensure a flat and tight fit.
- The geotextile must be anchored with nails or stakes at approximate two-foot spacing.
- When placement is complete, ensure the geotextile material is laid flat and wrinkle free, without folds, creases, or loose areas

The Contractor shall document proper surface profile following placement of the filter material and prior to installation of the riprap. If nominal water depths are greater than 5 feet, an underwater diving subcontractor may be required to facilitate the installation of the materials and to assist with documentation of the surface profiles and adequate thicknesses.

### 3.1.5.5 RIPRAP PLACEMENT

#### 3.1.5.5.1 IN-THE-DRY

Riprap shall be placed to the depth indicated on the design plans. The thickness of the riprap layer shall be placed with a tolerance of +/- 10% or as approved by the Engineer. Place the rock in 18-in minimum lifts to prevent segregation and to avoid displacement of the underlying material. Do not place rock by dumping into chutes or by similar methods likely to cause segregation or geotextile damage. Rearrange individual rocks, if necessary, to ensure uniform distribution. Riprap shall be free of silt or any other debris. If during the installation of rocks, the de-watered area becomes flooded, wash the rock to remove sediments and fines before commencement of grouting. At the upstream and downstream limits of the riprap shown on the contract drawings, for the final one foot of length, provide an additional one foot of depth of riprap to toe into the streambed and tie into the existing streambed elevations in accordance with the "Upstream/Downstream PGR Toe" detail shown on the design plan.

#### 3.1.5.5.2 IN-THE-WET

Riprap shall be placed to the depth indicated on the design plans. The thickness of the riprap layer shall be placed with a tolerance of +/- 10% or as approved by the Engineer. The depth of the layer may be required to be deeper, as directed by the Engineer, to account for "unknowns" associated

with under-water placement when the water depth is greater than 5 feet. Place the rock in 18-in minimum lifts to prevent segregation and to avoid displacement of the underlying material. Do not place rock by dumping into chutes or by similar methods likely to cause segregation or geotextile damage. Rearrange individual rocks, if necessary, to ensure uniform distribution. Riprap shall be free of silt or any other debris. At the upstream and downstream limits of the riprap shown on the contract drawings, for the final one foot of length, provide an additional one foot of depth of riprap to toe into the streambed and tie into the existing streambed elevations in accordance with the "Upstream/Downstream PGR Toe" detail shown on the design plan.

### 3.1.5.6 GROUTING

#### 3.1.5.6.1 IN-THE-DRY

The riprap shall be free of silt or any other debris in accordance with the design plans. Prior to grouting, power wash the riprap to remove silt and fines. The amount of grout to be installed shall be in accordance with the Table 5 below, dependent on the rock class size number. The grout pump shall have an adjustable flow control, delivery hose diameter between 1 ½ inch to 2 inches, and the ability to handle 3/8-inch diameter aggregate. Partially grout the void spaces within the riprap using a zig-zag grouting technique, to fill approximately one-third to one-half the void spaces. The target distribution of grout within the riprap matrix shall be such that about 2/3 of the grout should reside in the upper half of the riprap layer, with 1/3 of the grout penetrating the lower half. The grout shall not segregate when being applied to the riprap. The grout must not be allowed to pool on the surface of the riprap, nor puddle onto the filter at the base of the riprap. Grout along the immediate interface between the riprap and piers/abutments should be in accordance with the design plans. Allow open voids at the surface to maintain permeability in the PGR matrix. Closely monitor the construction methods to ensure surface openings are present and voids are distributed throughout the entire rock matrix. Allow the grout to cure twenty-four hours before permitting any activities on the PGR matrix.

<b>Table 5: Grouting Rate in-the-Dry Grouting Material Quantities</b>			
Riprap Size Class	Approximate $d_{50}$ size, inches	Nominal placement thickness, $2d_{50}$ , inches	Application Quantity (cubic ft / square yards)
R-6	12	24	2.7 – 3.2
R-5M	9	18	2.0 – 2.2
R-6M	12	24	2.7 – 3.2
R-7M	15	30	3.4 – 4.1

### 3.1.5.6.2 IN-THE-WET

The riprap shall be free of silt or any other debris in accordance with the design plans. The amount of grout to be installed shall be in accordance with the Table 6 below, dependent on the rock class size number. If the water depth exceeds five feet, the Contractor shall use an underwater diving subcontractor to assist with the installation of the grouting and to provide video and photographic documentation of the final installation. The grout pump shall have an adjustable flow control, delivery hose diameter between 1 ½-inch to 2-inches, and the ability to handle 3/8-inch diameter aggregate. Partially grout the void spaces within the riprap using the zig-zag grouting technique, to fill approximately one-third to one-half the void spaces. The target distribution of grout within the riprap matrix shall be such that about 2/3 of the grout should reside in the upper half of the riprap layer, with 1/3 of the grout penetrating the lower half. The grout shall not segregate when being applied to the riprap. The grout must not be allowed to pool on the surface of the riprap, nor puddle onto the filter at the base of the riprap. Grout along the immediate interface between the riprap and piers/abutments should be in accordance with the design plans. Allow open voids at the surface to maintain permeability in the PGR matrix. Closely monitor the construction methods to ensure surface openings are present and voids are distributed throughout the entire rock matrix. Allow the grout to cure twenty-four hours before permitting any activities on the PGR matrix.

<b>Table 6: Grouting Rate in the Wet Grouting Material Quantities</b>			
Riprap Size Class	Approximate $d_{50}$ size, inches	Nominal placement thickness, $2d_{50}$ , inches	Application Quantity (cubic ft / square yards)
R-6	12	24	2.7 – 3.2
R-5M	9	18	2.0 – 2.2
R-6M	12	24	2.7 – 3.2
R-7M	15	30	3.4 – 4.1

**3.1.5.7 DEWATERING**

When the construction can be performed with limited water diversion methods, as approved by the Engineer, then the installation of PGR shall proceed in the dry as defined on the design plans.

**3.1.5.8 SEDIMENTATION AND EROSION CONTROL SYSTEM**

A comprehensive Erosion and Sediment Pollution Control Plan (E&SPCP), in accordance with PennDOT standards and following the Pennsylvania Code Title 25 Environmental Protection Chapter 102 “Erosion and Sediment Control shall be provided with the design plans for the project.

**3.1.5.9 7.4 WATER QUALITY MANAGEMENT**

The Contractor shall meet the requirements of Section 3.1.6 and PennDOT standards for water quality management when construction is in-the-dry or in-the-wet and any conditions included in the permit requirements.

**3.1.5.10 TURBIDITY CURTAIN PLACEMENT**

The construction of the turbidity curtain for construction in-the-wet shall be as shown on the Plans, and as directed by the manufacturer and the Engineer for the designated site conditions.

To help minimize the adverse impact on the ecology in the immediate work area, the turbidity curtain shall initially be installed (unwrapped) as close as possible to the shore/bank area or adjacent to the bridge abutment or pier and gradually moved outward to its final location. This outward dragging motion help to prevent the inadvertent trapping of any aquatic organisms/invertebrates inside the curtained area. When the curtain reaches the final phased installation location (per design specifications/plans) the weight system at the base of the curtain shall rest uniformly on the riverbed and be anchored to the riverbank securely according to the

manufactures specification or as directed by the engineer using posts/stakes and ties. Depending on the length of the material, an overlap according to the manufacturer's specifications shall be included. The Contractor is responsible to maintain the stability of the turbidity curtains to effectively contain the work area as directed by the Engineer

In general, the turbidity curtain shall not be installed perpendicular to the direction of stream flow, such as across a river. Where applicable, the turbidity curtain shall be installed parallel to the normal flow of water, such as along a riverbank, and taper at a gradual angle toward the shore/bank. The final placement location and geometry shall be based on site conditions, site access areas, stable bank area, diverted water flow patterns and riverbed elevations. All construction activities that generate any sediment or turbidity into the waterway shall be contained within the turbidity curtain.

Unless otherwise directed by the Engineer, the Contractor shall begin installation from a shoreline anchorage and work along with the current in a downstream direction.

The turbidity curtain shall form a continuous vertical and horizontal barrier to suspended sediment. The bottom of the turbidity curtain shall rest in contact with the bottom of the waterway for the entire length of the turbidity curtain. The top of the turbidity curtain shall extend above the water surface with at least a 4-inch freeboard for all stages of water levels.

For installation of a floating turbidity curtain, it shall be floated into position, attached to the anchor lines, and then unfurled. The Contractor shall securely attach curtain panel ends together using rope lashings. The top lashing shall be securely tied to the anchor line. The Contractor shall place the anchors such that the turbidity curtain remains in the Plan location and none of the flotation devices are pulled under the water surface. If directed by the Engineer, the Contractor shall supply and place additional anchorage.

For installation of a staked turbidity curtain, stakes shall be installed along the turbidity curtain alignment as shown on the Plans. The stakes shall be driven into the ground to the depth and spacing as shown on Standard Construction Detail, Turbidity Curtain.

The curtain shall be securely fastened to the side of the stakes facing the work area generating the sediment and turbidity. At curtain panel ends, the two panels shall be overlapped a minimum of 6 inches and rolled and fastened together around a common stake to ensure a sediment-tight seam.

### 3.1.6 WATER QUALITY MANAGEMENT

#### 3.1.6.1 GENERAL

The standard presented in this document provides procedures and limitations for PGR construction in-the-dry and the in-the-wet.

The placement of PGR in-the-wet or in-the-dry shall meet the requirements of the PA Code Title 25, Chapter 93 “Water Quality Standards” and Pennsylvania Code Title 25 Environmental Protection Chapter 102 “Erosion and Sediment Control.

Circumstances that exclude the option of placing PGR in-the-wet (or without dewatering) include but are not limited to:

- Exceptional value streams
- Presence of threatened or endangered aquatic species within the work area or within (2) two miles downstream

Circumstances that should be evaluated based on site condition and could exclude the option of placing PGR without dewatering include but are not limited to:

- High quality streams
- Site with very little stream flow

The following requirements will be placed on all project that entail placement of PGR in-the-dry:

- Stream flow should not be returned to the project area until the grout has cured/or the surface has hardened (no less than (1) one-hour cure time) and the grout is flushed with stream water until the pH level falls below 9.0. The wash water must be pumped to an upland site located or filter bag to prevent reentry of the wash water to the waterway.

The placement of PGR in-the-dry requires dewatering of the site or working area using acceptable standard practice (see Section 3.1.5.5.1 and 3.1.5.6.1).

The placement of PGR in-the-wet requires turbidity curtains that enclose the site or working area and continuous monitoring of water quality (see Sections 3.1.5.5.2 and 3.1.5.6.2).

### 3.1.6.2 PLACEMENT OF PGR IN-THE-DRY

The Contractor shall meet the requirements of PennDOT standards for water quality management when construction is in the dry and any conditions included in the permit requirements.

### 3.1.6.3 PLACEMENT OF PGR IN-THE-WET

#### 3.1.6.3.1 GENERAL REQUIREMENTS

- a. The grout mix must have anti-washout admixture and must have mass loss less than 6 percent in accordance with US Army of Engineers Standards CRD-C 61 –

89A “Test Method for Determining the Resistance of Freshly Mixed Concrete to Washing Out in Water”.

- b. A turbidity curtain meeting the material guidelines mentioned in subsection 3.1.3 above and any other measure to minimize dispersion of sediment/suspended particles and minimize pH level increases outside the turbidity curtain shall be incorporated during the construction of PGR. For specific site conditions where water velocities impact the contained area an energy dissipation system might be required to maintain the effective function of the turbidity curtain per manufacturing requirements. Turbidity curtain placement shall extend a minimum of ten feet upstream and 10 feet downstream from PGR placement limits.
- c. The stream flow volume must be established, and the rate of pumping grout shall not exceed the stream flow to grout pumping ratio of 100 to 1.
- d. After completion of grout placement, the turbidity curtain and other measurements shall remain in place until pH of the water returns to the baseline levels.

#### 3.1.6.3.2 MONITORING WATER QUALITY

- a. Use pH probes with data logger to provide continuous monitoring. Sampling equipment shall be calibrated and available at the monitoring site prior to construction in order to establish the baseline water quality values. A minimum of two pH probes shall be on site and operational.
- b. There are always natural variations in pH levels in a stream. A “baseline” pH level shall be determined for the site from average readings for each day.
- c. Identify the baseline at thalweg (if present) and pools (if present), or the following locations, or as shown in the contract drawings and specification, or in the permit requirements:
  - 1. At thalweg (if present) and pools (if present), or at mid-channel of the bridge location, at the upstream and downstream faces of the superstructure.

2. At thalweg (if present) and pools (if present), or at mid-channel upstream at fifty feet, and (100) hundred feet from the turbidity curtain locations.
  3. At thalweg (if present) and pools (if present), or at mid-channel downstream at fifty feet, and hundred feet from the turbidity curtain locations.
- d. During the grout placement, the pH levels inside the turbidity curtain shall be measured at the start of grouting and every thirty minutes until the grout placement is completed. Measurement shall then be taken every hour until the pH level returns to the measured baseline inside the turbidity curtain.
  - e. During the grout placement, the pH levels at fifty and hundred feet downstream from turbidity curtain shall be measured at the start of grouting and every 15 minutes until the grout placement is completed. Measurement shall then be taken every hour until the pH level returns to the measured baseline at hundred feet from turbidity curtain.
  - f. Pumping of grout shall cease if pH levels at the downstream monitoring location outside the turbidity curtain reach a value of 8.5. Pumping may resume only if pH level remains at 8.5 for thirty minutes after cessation or begin to decline below pH level of 8.5. If pH level remains above 8.5, operation shall remain suspended until pH levels at monitoring locations return to 8.5 and either remain at that level for thirty minutes or continue to decline below pH level of 8.5. The pumping rate shall be reduced to prevent additional rises in pH levels.
  - g. If pH level rises to/or above 9.0 at the sampling locations (does not include levels within the turbidity curtain area if used), an inspection of downstream areas extending at least five-hundred feet shall be performed and any aquatic life impacts shall be recorded. If impacts are observed, the inspection shall then be extended downstream until occurrences have ceased.

- h. PA-DEP and the EPA Fish and Boat Commission shall be notified immediately if any aquatic life injury or mortality were observed, or any breach of containment area occurs.
- i. A report detailing the pH levels and operational adjustment that occurred during the project within thirty days of completion of the project shall be provided to the PA-DEP.

### 3.1.7 MEASUREMENT AND PAYMENT

#### 3.1.7.1 MEASUREMENT

The measurement for payment of PGR will be the total number of cubic yards of partially grouted riprap installed.

The demonstration of the Contractor's experience with PGR installation shall not be measured and shall be considered incidental to the work.

Excavation and filter material are not included in the bid item for PGR and will be measured separately under their respective items.

Water containment areas, dewatering measures, energy dissipation system, silt fence, water treatment basins, cleanup of the materials associated with providing the water containment area for sediment removal, and water pre-treatment prior to release back into the stream shall be measured separately.

#### 3.1.7.2 BASIS OF PAYMENT

The bid price shall include all costs for supplying, transporting, stockpiling, mixing, and placing all riprap and grout, along with all other related and necessary materials, work, equipment, and testing in accordance with the drawings and specifications.

Excavated material will be paid for separately under Item 204, Class 2. Waste material shall be disposed of in accordance with Section 105.14 of Publication 408.

Geotextile filter material shall be paid for under Item 212.

Granular filter material shall be paid for under Item 350.

## 3.2 PERMIT APPLICATION OF PGR TO SCOUR CRITICAL BRIDGE IN PENNDOT DISTRICT 6-0

With the assistance of PennDOT District 6-0 Technical Advisor, an existing scour critical bridge SR 2028 was selected to have PGR to protect the structure from scour. The bridge consists of a two-span concrete encased rolled steel I-beam structure. The bridge has a scour critical designation and it was originally constructed in 1931. The project was determined not to cause a significant reduction in the existing waterway opening, or significant change to the grades of approach roadways, or significant change to the overtopping characteristics, or significant change of the alignment, and most importantly, the existing structure will not be modified. When the available information for the selected bridge was reviewed, it was determined that a Hydrologic and Hydraulic (H&H) analysis was required for the selected bridge to determine the scour countermeasure design parameters and to show that the proposed countermeasure design would maintain and/or reduce water surface elevations during the regulated (100-yr) flood event. Additionally, bridge SR 2028 is classified as an Urban Collector; therefore, the PennDOT District 6-0 design (25-yr) flood was assessed for any increases in water surface elevation. The H&H Analysis for bridge SR 2028 was conducted in accordance with the design criteria provided in the Pennsylvania Department of Transportation's (PennDOT's) Publication 13M, Design Manual, Part 2, Highway Design, Chapter 10 (DM-2).

The H&H Analysis was performed to determine the flow velocity and peak discharge at the crossing of bridge SR 2028 and Sandy Run during various peak discharges. The information was then used to determine the impact of recurring floods on the bridge foundation and substructure, and to estimate the type and effects of scour at the bridge piers, bridge abutments, and stream bed/banks so that the structural integrity of the bridge can be maintained. Further, variables obtained from H&H Analysis were utilized to evaluate the potential impacts to Sandy Run following the installation of a structural countermeasure along the bridge abutments and pier, and to set the final countermeasure design.

The installation of the proposed countermeasure followed an assumed phased approach that allowed for access to parts of the channel, abutments and pier. The phase approach did not represent the finale design approach. Further, since all work for the proposed project was to be completed near the foundations of the existing structure, it was not anticipated that a detour or temporary bridge would be necessary. An explanation of the assumed phasing, H& H Analysis, and the summary of PGR scour countermeasure design parameter are presented in Appendix C

Following the selection of the existing scour critical bridge SR 2028 and the determination of PGR scour countermeasure design parameters, the final draft design guidelines of PGR at bridge piers and abutments was utilized to develop recommendations for the Plans, Specs, & Estimate (PS&E) package. The preparation and support service were done only Chapter 105 Water Obstruction and Encroachment Permit Under General Permit BWEW-GP-11 – Maintenance, for submittal to the Pennsylvania State Department of Environmental Protection (PSDEP) by District 6-0.

The recommended PS&E package includes layout dimensions for PGR at piers and abutments for construction in-the-dry and in-the-wet; riprap size and mechanical and physical properties of riprap; grout requirements for construction in-the-wet and in-the-dry; filter requirements; Type Site and Location (TSL); construction plans; construction specification; engineering calculations and estimates; recommendation for erosion and sedimentation pollution control plan (E&S plan); recommendation for environmental documentation; recommendation for environmental monitoring before, during, and after construction; recommendations for environmental testing. The recommended PS&E is presented in Appendix D.

### 3.2.1 OUTCOME OF PREAPPLICATION MEETING WITH COE AND DEP

A pre-application meeting was held with the DEP and COE to review/discuss in detail each phase of PGR construction at bridge SR 2028 and to determine the level of permitting required for the project. At the conclusion of the meeting, both regulatory agencies indicated a General Permit BWEW-GP-11 (GP-11) for maintenance, testing, repair, rehabilitation, or replacement of water obstructions and encroachments would not be applicable and required the highest level of permitting, Individual Permits (IP)—both agencies having determined that construction of PGR in-the-wet will likely cause more than minimal adverse impacts to aquatic life. The COE also specifically required a 404(b)(1) Guideline Analysis, which includes rigorous purpose, need, and alternative analysis.

The DEP and COE were mainly concerned with the level of water quality impacts from PGR installation in-the-wet and questioned the effectiveness and integrity of turbidity curtains as a Best Management Practice (BMP). Furthermore, the COE and DEP were concerned that the chemical integrity of the water quality would have adverse effects on aquatic life when installing PGR in-the-wet. The COE and DEP believed that the increase in alkalinity caused by the Portland cement-based grout would exceed the tolerance limits for most plants, invertebrate, and vertebrate aquatic species. Although the pH levels would be monitored as specified in the design guidelines, the DEP and COE felt that the water quality impacts would cause more than minimal adverse impacts on aquatic life. It should be noted that the DEP and COE mentioned that controlling the rate of grout application could correlate to the assimilation capacity of the waterway to insure dilution of the alkaline pollutants

According to PA Code Title 25, Chapter 93 (§ 93.7) Table 3 (19), which displays specific water quality criteria, pH levels for all surface waters must remain between 6.0 and 9.0. The design guidelines abide by this regulation since it specifically states that construction should cease if pH levels at the downstream monitoring location outside the turbidity curtain reach a value of 8.5 and that the pumping may only resume if pH level remain at 8.5 for thirty minutes after cessation or begin to decline below pH level of 8.5. This is clearly stated in Section 3.1.6.3 above in regard to the water quality management procedure intended to be implemented on site by the Temple research team.

The COE and DEP stated that the use of turbidity curtains may be appropriate in low gradient, low flow conditions, but the effectiveness of the turbidity curtain as a pollution control method would significantly decrease in high gradient or flooding conditions. Given this information the COE and DEP did not feel as though turbidity curtains could withstand the current site conditions. The COE quoted the PADEP Erosion and Sediment Pollution Control Program Manual (20), stating that turbidity curtains are generally used where earthwork (e.g. dredging operations, stream bank improvements, bridge pier construction, etc.) occurs within a water body, or along the shoreline, for relatively short periods of time, usually less than 1 month. Turbidity curtains should not generally be used where strong currents exist and should never be placed across flowing watercourses. They should also not typically be left in place during winter (20). For these reasons the COE concluded that turbidity curtains are rarely used as an erosion and sediment pollution control measure for the installation of scour protection along bridge piers and abutments in streams.

It should be noted that the PADEP Erosion and Sediment Pollution Control Program Manual (20) does not restrict the use of turbidity curtains in fast moving streams, it only recommends using a stronger curtain. The design considerations stated in the PADEP Erosion and Sediment Pollution Control Program Manual (20) listed below were used to develop the design guidelines specifications stated in Section 3.1.3 above.

- a) For ponds and other relatively still water bodies, the fabric should be relatively impermeable so as to provide a barrier between the clean water and the sediment-laden water. Runoff into this type of curtain should be minimized, due to limited available capacity.
- b) For moving water, such as in lakes and stream channels, provision should be made to allow passage of water through the curtain. This is normally done by constructing at least part of the curtain from a heavy filter fabric. While such curtains allow for some water movement through the curtain, the flow rate is low. Therefore, these curtains should not be installed across flowing watercourses. Turbidity barriers placed in stream channels should be placed parallel to the flow direction.
- c) Wherever the water body is not subject to tidal and/or wind and wave action, the curtain should extend the entire depth of the water and rest on (or be anchored to) the bottom. Failure to maintain contact with the bottom will allow sediment to move under the curtain. It is recommended that the height of the curtain be 20% greater than the depth of the water to allow for fluctuations.
- d) Wherever the water body is subject to significant tide, wind, or wave action, the weighted bottom of the curtain should not extend to the bottom of the water body. Wind and wave action can cause the bottom of the curtain to move along the bottom, stirring up sediment. Therefore, a minimum 1-foot gap should be provided between the bottom of the curtain and the bottom of the water body at mean low water.

- e) Curtain heights beyond 12-feet are generally not practical. Curtains installed deeper than this are subject to very large loads with consequent strain on curtain materials and the anchoring system.
- f) The overall length of the curtain should be 10% to 20% greater than the straight-line measurement of the perimeter to facilitate installation and reduce stress caused by wind and/or waves.
- g) Both ends of the curtain should be securely anchored to the shoreline.
- h) An excessive number of joints should be avoided. A minimum continuous span of 50-feet between joints is recommended. For stability purposes, the maximum span between joints should be 100-feet.
- i) For applications where it is desirable for water to pass through the curtain (e.g. when used instead of a baffle in a sediment basin), a curtain with one or more panels of screen fabric should be used. In this application, the curtain may remain in place over winter months.

The PADEP Erosion and Sediment Pollution Control Program Manual (March 2012) states that the turbidity curtain should be installed according to the manufacturer's standard guidelines (20). It also notes that the contractor should make sure all obstacles, impediments, and potentially damaging objects have been removed from the installation area prior to beginning the installation.

Due to extensive permit requirements necessary for an Individual Permit application, PennDOT District 6's Technical Advisors established a Permitting Team that had experience with Individual Permits. The goal of the Permitting Team was to modify or revise the project proposal in order to convince the DEP/COE to reduce the permit requirements from an IP to a GP-11. If the DEP/COE insisted on IP after project proposal revisions, the Permitting Team would evaluate the likelihood of the IP being approved by the State and Federal regulatory agencies

After further review of the construction phasing it became clear to the Permitting Team that the DEP/COE issues were not, necessarily, all about the means and methods but more about the magnitude of the project as a whole. The Permitting Team believed that the minimization of the environmental impacts would be key to obtaining permit approval. The best way the Permitting Team believed this could be accomplished was by scaling down the construction size in order to reduce the total impact on the stream. The Permitting Team suggested repairing only one span in the wet and performing the grouting application in small sub-sections, which would be staked out prior to grouting. By scaling down the grouting application, the temporary negative water quality impacts would be reduced.

The Permitting Team noted that the second pre-application meeting with the regulatory agencies must emphasize the water quality monitoring that will be performed during construction as well as the contingency plans to the DEP/COE at the next pre-application meeting. The team also emphasized that the project must be treated and presented as a research project and not a

specification. The five major points that were presented at the second pre-application meeting are listed below.

1. There is an immediate need for scour maintenance on the bridge SR 2028 abutments and pier.
2. Emphasize the construction phasing modification that scaled down the project's magnitude and grout application in-the-wet, which inevitably reduces the water quality impacts.
3. Emphasize that the project is specifically for research purposes, not specification development.
4. Emphasize that the site preparation procedures are similar to those already performed in-the-wet for other in stream construction applications.
5. Emphasize the purpose and need for the project which includes the following:
  - a. PGR is a permanent bridge scour solution
  - b. PGR installation in-the-wet will have less environmental impacts (short and long-term) than PGR application in-the-dry.
  - c. PGR installation in-the-wet will have less construction costs than those associated with installation in-the-dry.

The Permit Team presented a refined proposal that focused on the testing nature of the project, reduced the scope, and incorporated several different BMPs for pH control. BMP's for pH control were proposed as part of a multi-stage contingency plan. The plan, along with revised E&S phasing concepts, was presented to the agencies in a "working meeting" environment. Despite agency acknowledgement of the improvements and the merits of PGR, there continued to be doubt about the effectiveness of the proposed BMPs to avoid or reduce the significant water quality impacts and the BMP's applicability to real world application if cost savings is a goal of installing PGR in-the-wet. Additionally, the agencies did not see sufficient justification for the need to conduct PGR in-the-wet when a less impacting in-the-dry application is currently available and permissible. Agencies affirmed their decision to require the highest-level individual permits with a robust Environmental Assessment (EA) for the DEP Joint Permit application (JPA) and full-scale Section 404(b)(1) alternatives analysis for the United States Army Corps of Engineers (COE) Individual Permit (IP). COE indicated that the viable alternative to consider for alternative analysis in the permit application is large scale testing in a lab. For comparison, only a few projects in District 6-0 have previously required this level of permitting and these were large scale corridor-wide new capacity projects such as I-476 (Blue Route) and the more recent S.R. 202, Section 700 Parkway project.

The following statement was provided by the Permitting Team, which outlined their major findings regarding the likelihood of permit approval/denial and ultimately support their conclusion of a relatively high risk of permit denial for installation of PGR in the wet.

1. The 404(b)(1) analysis being referred to by the COE are the set of mandatory guidelines from the Clean Water Act and embedded in the COE-EPA MOA which guides the review of project alternatives as part of a permitting decision. The guidelines are considered “substantive criteria” for COE to determine impacts of a project and are also considered “binding regulations,” which means non-compliance is sufficient basis for permit denial. The COE’s repeated emphasis on this requirement suggests their intention towards strictness in permit and willingness to deny if the project is not shown to be the “least environmentally damaging practicable alternative to achieve the project purpose.”

There are three major and inter-related components to the 404(b)(1) alternatives analysis that are mandatory, which the Permitting Team did not believe this project could fully meet:

- a) A clear and concise Purpose and Need that justifies the impact
- b) Persuasive documentation that the proposed option is the least environmentally damaging practicable alternative to achieve the project purpose
- c) Documentation of effective impact avoidance and minimization

These are inter-related, especially the first two items because the project purpose and need are tied to the availability of other options. To gain acceptance of the purpose and need the project team would essentially have to show that the in-the-wet option is the only way to achieve Temple’s project goal of evaluation of effectiveness of the PGR technique. While Temple may insist that the PGR technique works optimally while constructed in-the-wet, the benefits of doing so must be shown to far outweigh the impacts to the affected environment and must meet the test of being a significantly better technique compared to the available alternative of doing the same process in-the-dry.

2. The identification of practicable alternatives is similar to The National Environmental Policy Act (NEPA) requirements in that the alternatives must be real options and achieve the same basic project purpose. In this case, PennDOT has traditional ways of performing scour countermeasure protection that are more familiar and acceptable to the regulatory agencies. Those existing methods, including PGR in-the-dry, are in fact typically approved as part of a Statewide Programmatic General Permit (SPGP). If the effort and time requirements to deploy this same project in-the-dry using a State Programmatic General Permit (SPGP) General Permit GP-11 versus an IP/JPA are compared, the difference would be considerable and only worthwhile if the justification for in-the-wet deployment is far superior to current techniques and can be done with minimal environmental impact.

With respect to the least damaging alternative review criteria, the burden is on the applicant to show that there is no less environmentally damaging and practicable alternative available. Given that the COE and DEP have approved PGR in-the-dry, this criterion will be the biggest obstacle to permitting and the lack of documentation will be adequate grounds for denial.

3. While it may seem self-determining at first glance, the COE and DEP must also determine if the project is “water-dependent” because there is in the law a “rebuttable presumption” that there is always a non-aquatic alternative. There may be the perception that any bridge project crossing a waterway inherently meets the water dependency rule. But in the Permitting Team’s review, the bridge is not the project, the countermeasure is the project, and that in itself is not necessarily water-dependent action. The agencies may not press this particular criterion in their review but if so, the applicant would again be in the position of having non-aquatic options such as PGR in-the-dry that could still meet the basic purpose and need.
4. The key recurring obstacle is a clear and environmentally justified construction of PGR in-the-wet. Any evidence must be sufficiently rigorous to show that it would outperform all other options and would be less damaging (or even “comparable in impacts”) than our current in-the-dry option. The lab options show general performance and cost effectiveness but never included testing of effective water quality BMPs at the same time. Although turbidity barriers were tested to determine their effect on water quality, pH levels with the turbidity barriers installed were shown to be significantly higher than allowed by the agencies. Right now, the only justifiable situations for using the in-the-wet option are in emergency repair situations or in excessively deep-water conditions where standard cofferdam or other in-the-dry methods would be infeasible

The Permitting Team believed that every effort was made to modify the scope of the project to meet agency concerns regarding water quality and has concluded that the applicant will have a less than reasonable chance (significantly less than 50%) of obtaining a permit with the current approach. Due to the substantial effort required to complete a draft of the required permit (significant Environmental Assessment, Pre and Post biological studies) it is recommended that it would be beneficial to conduct further complimentary research on developing a strong purpose and need statement for PGR construction in-the-wet. The purpose and need statement would need to thoroughly explain why construction of PGR in-the-wet is not only far superior to construction of PGR in-the-dry, but also outline the reasons why installing PGR in-the-wet has less of an environmental impact than installing PGR in-the-dry.

The following explains what would need to be researched, and what facts would need to be presented to the regulatory agencies for permit approval

The research study carried out so far highlights the lack of quantified documentation of the typical impacts associated with standard scour countermeasures constructed in-the-dry. The Permitting

Team suggested carrying out a research study using a combination of historical maintenance data and other data sources, in order to document and outline the environmental footprint of existing countermeasures used by various DOTs throughout the nation for scour countermeasures. The environmental impacts should include but are not limited to water quality and aquatic life impacts. The study should specifically include the duration of the environmental impacts and the ultimate consequences of the impacts so each impact can be scaled and quantified accordingly. The study should attempt to quantify the following information for both the standard scour countermeasure construction methods in-the-dry, as well as those associated with construction of PGR in-the-wet:

- a) Environmental impacts associated with the initial construction
- b) Environmental impacts associated with the maintenance required for both standard scour countermeasures and PGR installed in-the-wet
- c) Average service life of each scour countermeasure
- d) Average service life of scour critical bridges
- e) Average number of maintenance projects needed to be performed during each scour countermeasure's service life
- f) Average number of scour countermeasures installed during a scour critical bridge's service life

These figures could then be used to quantify the environmental impacts caused by construction and maintenance of scour countermeasures constructed in-the-dry and in-the-wet for a scour critical bridge's service life. In order for this to be performed, a mathematical model would need to be developed to quantify the environmental impacts, duration of impacts, and consequences that result from the impacts. This information could then be compared and evaluated to help justify the merits for longer term maintenance solutions such as PGR, especially in combination with high quality BMPs. The study would also provide the regulatory agencies with an in-depth, detailed report outlining the environmental impacts associated with both (dry and wet) construction methods, with the intention of proving that construction in-the-wet has less of environmental impact than construction in-the-dry

### **3.3 MODIFICATION OF PGR PERMIT APPLICATION TO SCOUR CRITICAL BRIDGE SR 2028 IN PENNDOT DISTRICT 6-0**

The Temple research team believes the design guidelines, E&S plans, and construction phasing for PGR installation in-the-wet presented to the regulatory agencies met the standards stated in the PA Code Title 25 (19) and PADEP Erosion and Sediment Pollution Control Program Manual (March 2012) (20) specifically relating to the use of turbidity curtains and water quality monitoring.

The main issue the Temple research team was not able to address without further research was the purpose and need statement required by the COE and DEP. According to the Permitting Team, in order to develop a clear and effective purpose and need statement, the Temple research team would need to carry out a study similar to the one suggested in Section 3.2.1 above. Although, the suggested study in Section 3.2.1 would be helpful to provide the DEP and COE a strong purpose and need statement, it would be difficult to perform since there is limited research available for construction of PGR in-the-wet. The only research study that would be applicable to evaluate the environmental impacts of construction of PGR in-the-wet is the one performed by Lagasse at the University of Colorado (8). Although Lagasse's research did provide beneficial information used for this research project, a field test in the open environment was not performed. The construction of PGR in-the-wet field test proposed by Temple's research team would provide the information necessary to directly compare construction in-the-wet to construction in-the-dry. The proposed field test would also provide the necessary information to perform the suggested research study in Section 3.2.1 above. Without the field study, Temple's research team feels as though there is not enough scientific research information available to directly compare the environmental impacts associated with PGR construction in-the-dry to PGR construction in-the-wet. Thus, the Temple research team feels as though the study recommended by the Permitting Team would not yield valid results with the current information available and would not be feasible without performing construction of PGR in-the-wet through a field study first.

If the proposed field study were carried out and construction of PGR in-the-wet were performed, Temple's research team would be able to directly evaluate the environmental impacts of construction PGR in-the-wet to construction in-the-dry by performing the study suggested in Section 3.2.1. If the study suggested in Section 3.2.1 concluded that the environmental impacts associated with standard scour countermeasure construction in-the-dry were greater than those associated with PGR construction in-the-wet, the team would be able to develop a strong purpose and need statement which would convince the regulatory agencies to provide permitting for PGR construction in-the-wet. But without performing the field study proposed by Temple's research team first, it would not be feasible to provide the DEP and COE with valid scientific research comparison results.

Given the above information, the Temple research team and PennDOT District 6-0 Technical Advisors decided to change the application of PGR to the selected scour bridge SR 2028 to only be installed in-the-dry, which allowed the permit to be reviewed as a GP-11. Although construction will be performed in-the-dry for this project, it is important for PennDOT to evaluate construction of PGR in-the-wet as a viable scour countermeasure option and is insistent that the design guidelines provided to the DEP and COE meet the regulations set forth by both regulatory agencies

Although this research project can be used as a standalone document, it would be beneficial to conduct further, complimentary research on PGR in-the-wet. The research study of PGR in-the-wet should quantify the environmental impacts with the initial impact of construction and maintenance on the water quality and aquatic life. Such research would allow the State of

Pennsylvania to expand their knowledge and experience with PGR as a scour countermeasure and create more economical and functional practices throughout the state.

## CHAPTER 4: APPLICATION OF PGR IN-THE-DRY TO PENNDOT DISTRICT 6-0

### SCOUR CRITICAL BRIDGE SR 2028

---

Based on the design guidelines developed in Section 3.1, the PS&E package and the General Permit BWEW-GP-11 for the construction of PGR in-the-dry at PennDOT District 6-0 scour critical bridge SR 2028 was prepared by Designer and approved by the designated agencies. Under Force Account Agreement, PennDOT District 6-0 selected an experienced contractor to construct the PGR in-the-dry at bridge SR 2028. The construction of PGR at bridge SR 2028 started on November 10, 2017 and was completed on December 18, 2017. Based on the construction process, the test-pit and “Design Guidelines of PGR at Bridge Piers and Abutment” are revised accordingly.

#### 4.1 SITE DESCRIPTION

To determine the effectiveness of PGR as a scour countermeasure, the developed design guidelines of PGR at bridge piers and abutments was applied to PennDOT District 6-0 bridge carrying State Route (SR) 2028 (Camp Hill Road) over Sandy Run, in Whitmarsh Township, Montgomery County PA. The intent of the project was to restore the original streambed condition by repairing a scour hole, removing a sediment bar, and installing PGR to prevent future scour. Six inches of natural streambed material will be placed over the PGR to achieve the original streambed condition.

The existing structure shown in Figure 4 was originally constructed in 1931. The bridge is a two-span concrete encased rolled steel I-beam bridge, with a total length of approximately 46-feet and a width of 36-feet. The bridge features one 3-foot wide, reinforced concrete pier that runs parallel to Sandy Run, as well as two reinforced concrete abutments that taper in width from 4'-6" at the bottom to 2'-6" at the top. The structure is surrounded by hills and valleys with steep side slopes in convex linear shapes. Due to degradative scour action, the structural longevity of the bridge has come into question. The existing flow conditions have caused an accumulation of sediment and debris, as well as deep scour holes throughout the project area. The streambed elevation under Span 2 (right span looking downstream), between the abutment and the pier, has steadily increased in height due to particle migration as shown in Photo 1. Additionally, a large scour hole has formed below Span 1 (left span looking downstream), between the abutment and the pier as shown in Photo 2.

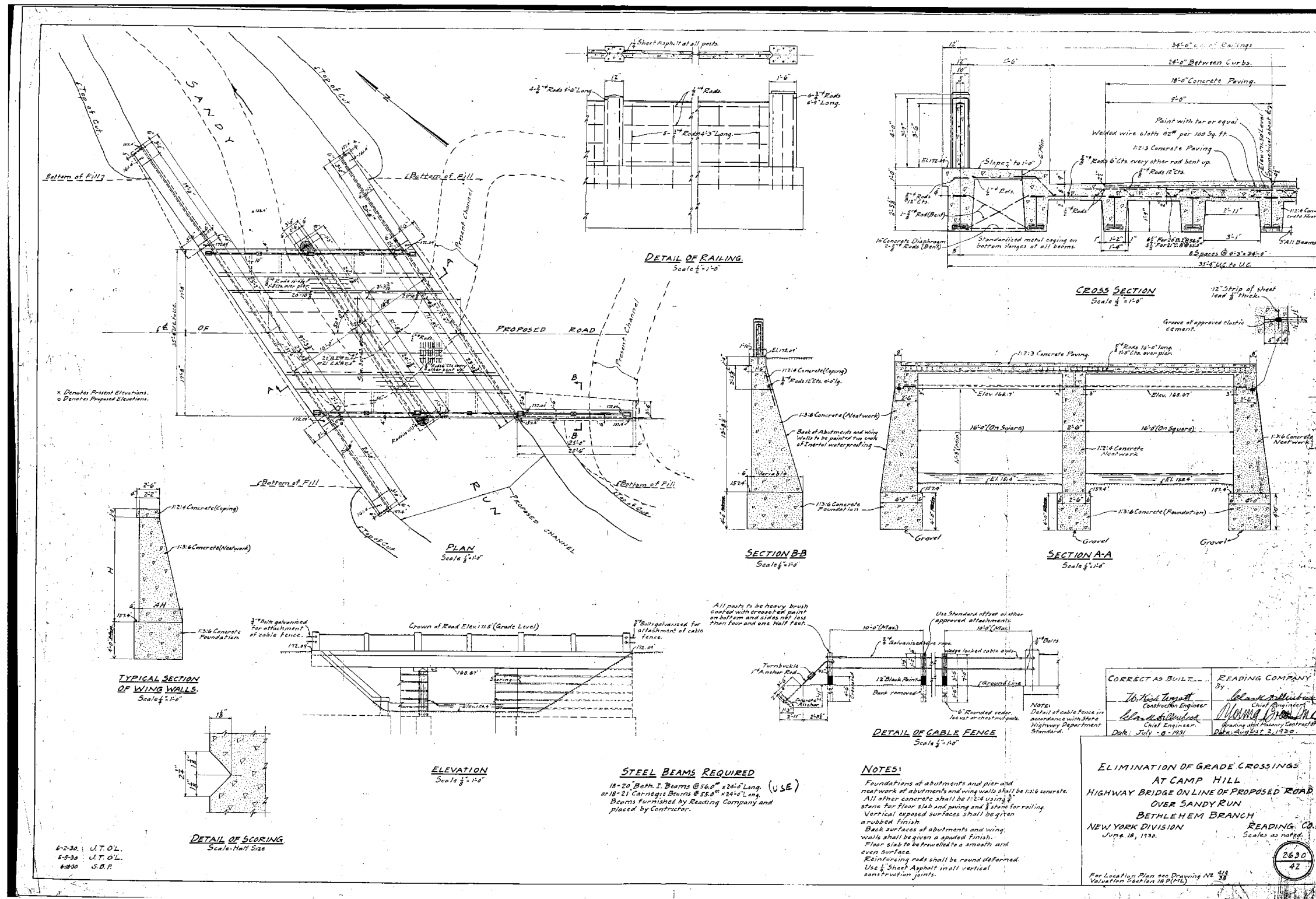

Figure 4 Bridge carrying State Route (SR) 2028 (Camp Hill Road) over Sandy Run



Photo 1 Span 2 Looking Upstream Sediment Deposition



Photo 2 Span 1 Looking Down Stream Formation of Scour Hole

#### 4.2 EROSION AND SEDIMENT CONTROL PLAN – SEQUENCE OF CONSTRUCTION

As part of the pre-application meetings with DEP and COE, it was determined that the PGR riprap must be installed in-the-dry to satisfy GP-11 permit requirements. As such, the PGR countermeasure will utilize temporary phased stream diversion to complete the required work. Further, the PGR countermeasure will re-establish the existing riverbed geometry/elevations, will be installed across the full channel of the bridge, and will include a low flow channel in Span 1 to encourage aquatic organism passage. The PGR countermeasure will be installed flush with the streambed such that the top surface elevation of the final installation is level with the natural geometry of the surrounding streambed. The E&S sequence of construction is as follows:

- I. During Phase 1, Span 2 will be isolated and the stream will be diverted under Span 1 as shown in Figure 5, allowing the contractor to complete the required work under Span 2. The construction sequences of Phase 1 are:
  1. Install compost filter socks and other E&S control measures as shown on the plans.
  2. Install temporary protection fencing along wetland mitigation limits as shown on plans.
  3. Construct rock construction entrance (RCE) for site access. Clear and grub only as needed to access work area.
  4. Install temporary stream diversion devices for phase 1 work as shown on plans.
  5. Dewater the construction area and begin work under Span 2 in dry conditions.
  6. Remove accumulated sediment under Span 2 and excavate to achieve subgrade elevation for PGR installation.
  7. Stockpile waste materials upland as indicated on the E&S plans.

8. Place stone layers as required for partial grouting of the rocks as indicated on E&S plans.
  9. Replace streambed material above PGR as indicated on the E&S plans to restore natural channel bottom.
  10. Upon completion of in stream work, remove temporary stream diversion devices and prepare for Phase 2 construction.
- II. During Phase 2, Span 1 will be isolated, and the stream will be diverted under Span 2 as shown in Figure 6. This will allow the contractor to work within the stream bank and install the PGR in-the-dry. The construction sequences of Phase 2 are:
1. Inspect all perimeter erosion and sediment control devices.
  2. Install rock causeway with pipes as shown on E&S plans and details.
  3. Install temporary stream diversion devices for Phase 2 work to establish dry work area as shown on plans.
  4. Dewater the construction area and begin work under Span 1.
  5. Remove sediment and perform minimal grading to shape the streambed for the installation of the PGR. Excavate as needed at pier and abutment to achieve subgrade elevation.
  6. Place stone layers as required for partial grouting as shown on E&S plan details.
  7. PGR as indicated on the E&S plans.
  8. Place streambed material back on top of the PGR to restore natural channel bottom.
  9. Haul excess waste materials offsite.
  10. Upon completion of work in the stream, remove temporary stream diversion devices and rock causeway.
  11. Permanently stabilize and restore disturbed areas by placing topsoil, seeding, mulch and soil supplements as depicted on the plans.
  12. Remove E&S control measures after all areas have been permanently stabilized. Refer to stabilization notes for permanent stabilization requirements.
  13. Remove temporary access road from downstream right bank and re-establish surface.

DISTRICT	COUNTY	ROUTE	SECTION	SHEET
6-D	MONTGOMERY	2028	PGR	8 OF 9
WHITEMARSH TOWNSHIP				
REVISION NUMBER	REVISIONS	DATE	BY	

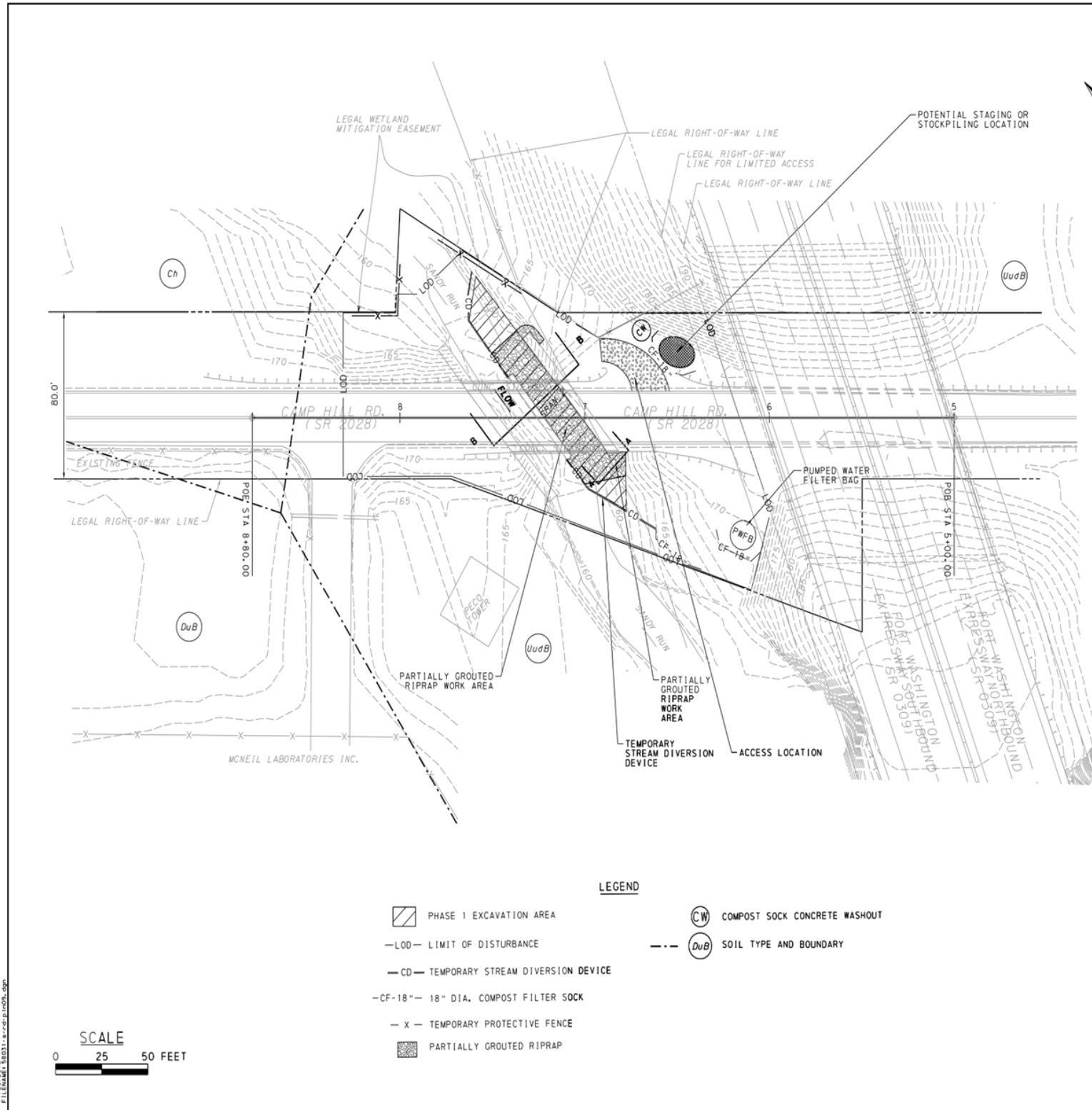

**NOTES**

1. PHASE 1 EXCAVATION TO OCCUR WITHIN DESIGNATED AREAS ONLY.
2. PUMP AS REQUIRED TO MAINTAIN DRY WORK AREAS. PUMP WATER FROM WORK AREAS MUST BE DISCHARGED THROUGH A SEDIMENT CONTROL DEVICE SUCH AS A PUMPED WATER FILTER BAG.
3. TEMPORARY PROTECTIVE FENCING SHALL BE PLACED ALONG WETLAND MITIGATION LIMITS DOWNSTREAM OF THE BRIDGE TO PREVENT ACCESS TO THE RESTRICTED AREA.
4. INSTALL PARTIALLY GROUDED RIPRAP IN DESIGNATED AREAS IN DRY CONDITIONS.
5. AT ALL SUBSTRUCTURES, PGR SHALL BE INSTALLED LEVEL WITH THE TOP OF FOOTINGS.
6. THE PGR SHALL BE INSTALLED TO THE LIMITS AND DETAILS INDICATED ON THE DESIGN PLANS. REFER TO PARTIALLY GROUDED RIPRAP DETAILS.

**LEGEND**

- PHASE 1 EXCAVATION AREA
- LOD - LIMIT OF DISTURBANCE
- CD - TEMPORARY STREAM DIVERSION DEVICE
- CF-18 - 18" DIA. COMPOST FILTER SOCK
- X - TEMPORARY PROTECTIVE FENCE
- PARTIALLY GROUDED RIPRAP
- CW - COMPOST SOCK CONCRETE WASHOUT
- DuB - SOIL TYPE AND BOUNDARY

**PHASE 1  
EROSION AND SEDIMENT  
CONTROL PLAN**



**Figure 5 E&S Sequence of Construction – Phase 1**

DISTRICT	COUNTY	ROUTE	SECTION	SHEET
6-0	MONTGOMERY	202B	PGR	9 OF 9
WHITEMARSH TOWNSHIP				
REVISION NUMBER	REVISIONS	DATE	BY	

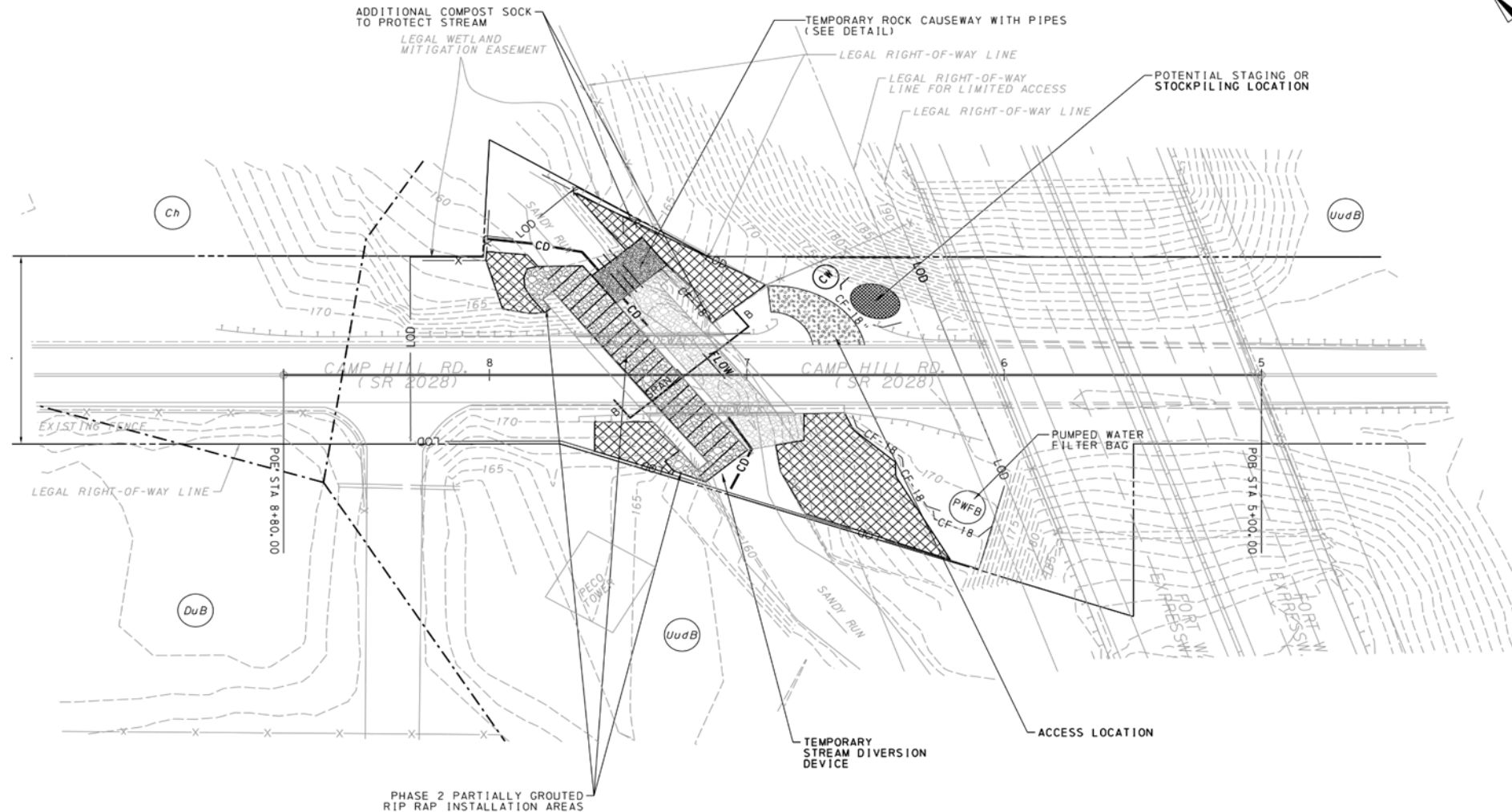

**NOTES**

1. PUMP WORK AREA AS REQUIRED TO MAINTAIN DRY WORK AREAS. PUMPED WATER FROM WORK AREAS MUST BE DISCHARGED THROUGH A SEDIMENT CONTROL DEVICE SUCH AS A PUMPED WATER FILTER BAG.
2. TEMPORARY CONSTRUCTION FENCING SHALL BE PLACED ALONG WETLAND MITIGATION LIMITS DOWNSTREAM OF THE BRIDGE TO PREVENT ACCESS TO THE RESTRICTED AREA.
3. ADJUST AND INSTALL ADDITIONAL COMPOST FILTER SOCK AS REQUIRED FOR PHASE 2.
4. INSTALL PARTIALLY GROUTED RIP RAP IN DESIGNATED AREAS IN DRY CONDITIONS.
5. AT ALL SUBSTRUCTURES, PGR SHALL BE INSTALLED LEVEL WITH THE TOP OF FOOTINGS.

**LEGEND**

- PHASE 2 EXCAVATION AREA
- LOD- LIMIT OF DISTURBANCE
- PIPES UNDER TEMP CAUSEWAY
- CD- TEMPORARY STREAM DIVERSION DEVICE
- CF-18"- 18" DIA. COMPOST FILTER SOCK
- X - TEMPORARY PROTECTIVE FENCE
- EROSION CONTROL BLANKET
- PARTIALLY GROUTED RIPRAP
- (CW) COMPOST SOCK CONCRETE WASHOUT
- (DuB) SOIL TYPE AND BOUNDARY

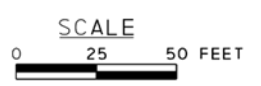

PHASE 2  
EROSION AND SEDIMENT  
CONTROL PLAN

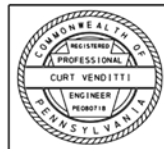

**Figure 6 E&S Sequence of Construction – Phase 2**

The estimated cost for the construction of the PGR scour countermeasure is \$260,415.25. The breakdown of the cost is shown in Table 7.

Table 7 Estimated Construction Cost of PGR Scour Countermeasure					
Item Number	Description	Quantity	Unit	Unit Cost	Total Item Cost
0201-0001	CLEARING AND GRUBBING	1	LS	\$15,000.00	\$15,000.00
0203-0001	CLASS 1 EXCAVATION	485	CY	\$50.00	\$24,250.00
0212-0002	GEOTEXTILE, CLASS 2, TYPE A	484	SY	\$2.00	\$968.00
0212-0014	GEOTEXTILE, CLASS 4, TYPE A	45	SY	\$5.25	\$236.25
0601-0311	12" THERMOPLASTIC PIPE, GROUP I, 15'-1.5' FILL	60	LF	\$65.00	\$3,900.00
0608-0001	MOBILIZATION	1	LS	\$50,000.00	\$50,000.00
0703-0025	NO. 57 COARSE AGGREGATE	68	CY	\$57.00	\$3,876.00
4703-0025	*NO. 57 COARSE AGGREGATE, MODIFIED	23	CY	\$120.00	\$2,760.00
0803-0001	PLACING STOCKPILED TOPSOIL	65	CY	\$65.00	\$4,225.00
0811-0003	TEMPORARY PROTECTIVE FENCE	70	LF	\$12.00	\$840.00
0845-0001	UNFORESEEN WATER POLLUTION CONTROL	5000	DOL	\$1.00	\$5,000.00
0849-0010	ROCK CONSTRUCTION ENTRANCE	1	EA	\$1,750.00	\$1,750.00
0850-0031	ROCK, CLASS R-3	25	CY	\$115.00	\$2,875.00
0850-0034	ROCK, CLASS R-6	270	CY	\$150.00	\$40,500.00
0855-0003	PUMPED WATER FILTER BAG	1	EA	\$1,000.00	\$1,000.00
0855-0004	REPLACEMENT PUMPED WATER FILTER BAG	1	EA	\$550.00	\$550.00
0867-0018	COMPOST FILTER SOCK, 18" DIAMETER	140	LF	\$17.50	\$2,450.00
0868-0100	COMPOST BLANKET - SEEDED WITH FORMULA B	288	SY	\$7.50	\$2,160.00
0868-0104	COMPOST BLANKET - SEEDED WITH FORMULA L	125	SY	\$8.00	\$1,000.00
0901-0001	*MAINTENANCE AND PROTECTION OF TRAFFIC DURING CONSTRUCTION	1	LS	\$2,000.00	\$2,000.00
9000-0001	*TEMPORARY STREAM DIVERSION SYSTEM	1	LS	\$40,000.00	\$40,000.00
9000-0002	*PARTIALLY GROUTING OF RIPRAP	54	CY	\$550.00	\$29,700.00
9000-5000	*CONCRETE WASHOUT	1	EA	\$1,700.00	\$1,700.00
Sub Total					\$236,740.25
10% Contingency					\$23,675.00
TOTAL					\$260,415.25

#### 4.3 SPECIFICATION ITEM 9000-0002 PARTIALLY GROUTED RIPRAP

Specifications were developed for the PGR countermeasure and they are as follows:

**DESCRIPTION** - This work is the construction of partially grouted riprap scour protection at existing piers and abutments.

**MATERIAL** –

(a) Rock –

1. General- Use rocks conforming to requirements as specified in Section 850.2 (a) 1.
2. Size and Gradation- Use only Class R-6 rocks as specified in Section 850.2 (a) 2.

(b) Geotextile –

1. General – Use geotextiles conforming to requirements as specified in Section 735.1
2. Use only Geotextile – Class 4, Type A as specified in Section 735.1 (b)

1.

(c) Grout –

1. Cement- Type I or Type II, Section 701.

2. Fine Aggregate- Type A, Section 703.1.
  3. Coarse Aggregate- AASHTO Number 8, Section 703.2.
  4. Water- Section 720.1
  5. Air Entraining Admixtures- Section 711.3(d).
  6. Water Reducing Admixtures- Section 711.3 (f).
- (d) Granular Filter- Coarse Aggregate- AASHTO Number 57 Type A, Section 703.2.

**MATERIAL TESTING –**

The contractor is to submit grout mix results from a certified material testing laboratory for the Department review and approval. The grout mix must comply with design parameters in Table 8 and the material testing requirements of this section. Do not begin the construction prior to the approval of grout mix

<b>Table 8: Target Grout Mix Design</b>	
<b>Material</b>	<b>Quantity by weight for one cubic yard of grout (pounds)</b>
Cement- Type I or Type II	740 to 760
Fine Aggregate - Type A	1,180 to 1,200
Coarse Aggregate- AASHTO Number 8	1,180 to 1,200
Water-Cement Ratio (w/c)	0.40 to 0.45
Air Entrained Admixture	Manufacturer Recommendation
Water-Reducing Admixture	Manufacturer Recommendation

- The grout mix shall result in a wet grout density ranging 120 to 140 lb/ft<sup>3</sup>. Wet densities outside this range must be rejected and the mix must be reevaluated for material properties of the individual constituents.
- Spread Test - Using ASTM C 1611 “Standard Test Method for Slump of Self-Consolidating Concrete” Procedure B, referenced as “Spread Test”. The average measure diameter of the “Spread Test” is 15.0 to 18.0 inches.
- The grout mix shall result a minimum air content of 6% in the plastic state.
- The grout mix shall result a minimum strength of 2500 psi at 28 days.

***PARTIALLY GROUTED RIPRAP TEST PIT –***

Upon approval of the grout mix, the contractor shall conduct a demonstration in accordance with the provided “PGR Mock-up Training Test Pit Set Up” for observation and the Engineer’s approval. The Department will confirm the location, date and time of the test.

***FIELD QUALITY ASSURANCE PROCEDURE FOR GROUT MIX –***

Conduct the Spread Test per the Material Testing Section. Perform the Spread Test a minimum of two times per batch, once upon delivery and once approximately when half of the batch has been used

The grout shall be delivered to the site with 10% less water than indicated in the approved grout mix design. The final grout consistency shall be developed via a trial and error procedure according to the following steps:

- Upon arrival at the site, add the required admixtures per material specification and mix for five minutes. Discharge a small sample into wheelbarrows for Spread Test.
- Perform an initial Spread Test as specified in ASTM C 1611 Procedure B. Record the average measurement in the orthogonal direction and compare with the required design parameters of the Material Testing Section. The Engineer will verify that the grout mix complies with the required parameters.
- Add additional water if required and remix for five minutes, and retest.
- The Engineer will not approve the grout mix if the total elapsed time since the initial batching exceeds 100 minutes.
- Grout that meets the Spread Test and elapsed time requirements shall be considered approved and can be used for partially grouting the riprap.

***CONSTRUCTION*** – Perform this work as shown on the plans and as follows:

(a) Prior to any streambed excavation, document existing streambed elevations upstream and downstream of the proposed limits of the partially grouted riprap installation.

(b) Perform all work in a dewatered and dry environment.

(c) Excavation and Streambed Preparation- Prepare the area required for the full cross section of partially grouted riprap as indicated in the design plans while providing a low flow channel. This preparation may include, but is not limited to excavating, removing unsuitable material, backfilling, clearing and grubbing as specified in Section 201.3. Stockpile excavated streambed material to backfill the partially grouted riprap installation. Place 2” of No. 57 Coarse Aggregate as shown on the design plans to create a level base.

(d) Geotextiles- Place Class 4, Type A non-woven geotextiles, as specified in Sections 735, 212.2 and 212.3(d). Carefully place 6” of No. 57 Coarse Aggregate, Type A, on the geotextile to avoid

voids, gaps, tears or holes in the geotextiles as shown on the design plans. If any damages are observed, the geotextile must be either repaired or replaced.

(e) Riprap Placement- Riprap shall be placed to the depth indicated on the design plans. Place the rocks in 18-in minimum lifts to prevent segregation and to avoid displacement of the underlying material. Do not place rocks by dumping into chutes or by similar methods likely to cause segregation or geotextile damage. Rearrange individual rocks, if necessary, to ensure uniform distribution. Riprap shall be free of silt or any other debris. If, during the installation of R-6 rocks, the dewatered area becomes flooded, wash the R-6 rocks to remove sediments and fines before commencement of grouting. At the upstream and downstream limits of the riprap shown on the contract drawings, for the final 1-ft of length, provide an additional 1-ft of depth of riprap to toe into the streambed and tie into the existing streambed elevations in accordance with the “Upstream/Downstream PGR Toe” detail.

(f) Grouting- Prior to grouting, power wash the riprap to remove silt and fines. The amount of grout to be installed shall be in accordance with the Table 9 below, dependent on the type/size of rock riprap used. The grout pump shall have an adjustable flow control, delivery hose diameter between 1 ½” and 2”, and the ability to handle 3/8” diameter aggregate. Partially grout the void spaces within the riprap using the zig-zag grouting technique to fill approximately one-third to one-half the void spaces. Grout along the immediate interface between the riprap and piers/abutments should be in accordance with the design plans. The stockpile of natural streambed material shall be placed to the depth indicated on the design plans. The top surface elevation for the final riprap installation shall be consistent with the natural geometry of the surrounding streambed and with the documented existing streambed elevations.

<b>Table 9: Grouting Rate in-the-Dry Grouting Material Quantities</b>			
Riprap Size Class	Approximate d50 size, inches	Nominal placement thickness, 2d50, inches	Application Quantity (cubic ft / square yards)
R-6	12	24	2.7 – 3.2

Notes:

1. The thickness of the riprap layer shall be placed with a tolerance of +/- 10% or (as approved by the Engineer).
2. The grout shall not segregate when being applied to the riprap.
3. The target distribution of grout within the riprap matrix shall be such that about 2/3 of the grout should reside in the upper half of the riprap layer, with 1/3 of the grout penetrating the lower half.

4. Allow open voids at the surface to maintain permeability in the rock matrix. Closely monitor the construction methods to ensure surface openings are present and voids are distributed throughout the entire rock matrix.
5. The grout must not be allowed to pool on the surface of the riprap, nor puddle onto the filter at the base of the riprap.
6. Do not fill more than 50% of the total voids with grout.
7. Do not grout the entire surface of the rock.
8. Fully grout the rock along vertical surfaces of the abutments and pier.
9. Allow the grout to cure 24 hours before permitting water to inundate the rock matrix.
10. Bury ends of Partially Grouted Riprap at upstream and downstream limits of work.
11. Place 6" of natural stream bed material on top of the completed Partially Grouted Riprap as shown on construction plans

**MEASUREMENT AND PAYMENT** – Cubic Yard.

#### 4.4 TEST-PIT

As specified in the PGR specification and prior to the construction of PGR countermeasure, the contractor shall conduct a demonstration of the various aspects of PGR for scour countermeasures at bridge piers and abutment for observation and ultimate approval by PennDOT District 6-0 engineer. The demonstration activities include grout mix design for dry application and the construction of a test-pit having the same thickness as the standard riprap section shown on the plan.

The test-pit plan of the draft design guidelines of PGR at bridge piers and abutment, Section 3.1.5.2 Figure 3, was constructed by the contractor without lining the tested-pit with plastic sheeting.

The Contractor furnished the materials needed to build the form for the test-pit, Class R-6 rocks, Geotextile – Class 4, Type A, and coarse aggregate AASHTO Number 57 Type A. The delivered Class R-6 rocks had substantial amount of rock size of 24" and larger. The delivered Class R-6 rocks seemed to be more toward Class R-7 and R-8 than R-6. Further, the delivered rocks had substantial amount of silt and sediments on the surface. The contractor attempted to pressure wash the entire pile with a pressure washer but had no success. Eventually, the contractor pressure washed each rock individually before placing it in the test-pit.

At the PennDOT Montgomery County Maintenance Facility yard, the test-pit form was constructed using 8'-0" long by 8'-0" wide by 3'-6" deep frame. The base of the test-pit was leveled and a sheet of Geotextile – Class 4, Type A was placed on top. The frame was placed on top of the geotextile as shown in Photo 4, and 5. Coarse aggregate AASHTO Number 57 Type A was placed in a 6-inch layer on top of the geotextile as can be seen in Photo 6. Individual Class R-6 rocks were pressure washed with a pressure washer. Due to the considerable number of rocks size 24" and larger the contractor attempted to place the smaller sized rocks on top of the coarse aggregate to minimize the void size between the individual rocks as shown in Photo 7. This was difficult to manage since most of the rocks were of size 24" and larger. In various sections of the test-pit one rock of size 24" covered the entire depth of the cross-section of 24", which did not exhibit the intended standard riprap section shown on the plan. The contractor attempted to use the smaller rocks to fill the void between the larger size rocks but there was insufficient amount of smaller rocks to properly fill the voids. Hand placed rocks were placed at one side of the test-pit to simulate an abutment or pier wall. Further, the containment of the test-pit form made it difficult for the contractor to properly place the rocks. Photo 8 shows the final rocks placement in the test-pit.



Photo 3 Test-Pit Forum

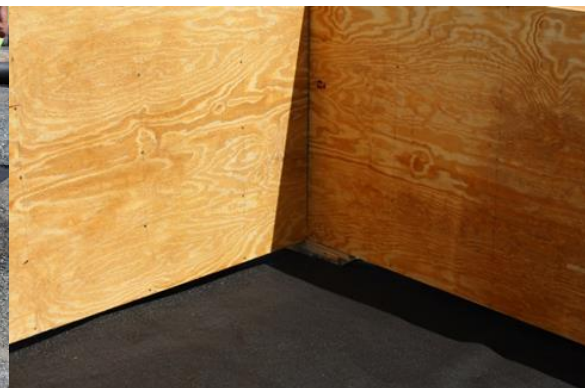

Photo 4 Interior of Test-Pit Form



Photo 5 Test-Pit Form with Exterior Support



Photo 6 Six-inch Number 57 Type A Aggregates Spread on Top of the Geotextile Class 4, Type A



Photo 7 Placement of Rocks



Photo 8 Final Rock Placement in the Form

An unspecified amount of the required grout mix was delivered to the site in a concrete truck mixer. The design specifications state that the grout shall be delivered to the site without admixtures and with 10% less water than indicated in the approved grout mix design. According to design specifications, it states that the final grout consistency shall be developed via a trial and error procedure according to the following steps:

- Upon arrival at the site, add the required admixtures per material specification and mix for five minutes. Discharge a small sample into wheelbarrows for Spread Test;
- Perform an initial Spread Test as specified in ASTM C 1611 Procedure B. Record the average measurement in the orthogonal direction and compare with the required design parameters of the Material Testing Section. The Engineer will verify that the grout mix complies with the required parameters;
- Add additional water if required and remix for (5) five minutes, and retest.

The design specifications were not followed by the contractor. When the grout arrived, a small amount was discharged into wheelbarrow for testing. The tests, ASTM C 1611 “Standard Test Method for Slump of Self-Consolidating Concrete” Procedure B (referenced as “Spread Test”), and the European Flow Table Test “Tap-Test,” were conducted. The spread test had an average measured diameter of 16.5” and the Tap-Test had an average measured diameter of 12.5” before tapping and 18.5” after tapping. The spread-test result was within design specification of average measure diameter of 15.0 to 18.0 inch. Thus, the grout mix was approved to partially grout the riprap in the test-pit.

The grout was transferred into the screen of the hopper of a line grout pump. The pump had a 2-inch diameter flexible placing hose. The end of the hose was attached to 90-degree elbow tube. Before partially grouting the riprap in the test-pit a small amount of grout was pumped on the ground to test the flow rate. The grout pump was clogged due to the present of large chip of concrete and aggregate size greater than 3/8 inch. The pump was cleaned and tested again. The grout slowly flowed out of the hose and the operator was able to control the flow of the grout. The grout was pumped along the side of the form that was intended to simulate the wall of an abutment or pier and then the void spaces of the riprap were partially grouted using a zig-zag

grouting technique. Photo 9 shows the grout along the side of the test-pit wall. Due to the large size of the rocks and large void spaces between them, the grout spread to the bottom of the test-pit without filling the voids along the vertical section as shown in Photo 10. Further, the elbow tube, shown in Photo 11, was very difficult to maneuver around the surface of the rocks. The final grouting of the test-pit can be seen in Photo 12. The grout was left to cure for 24 hours. After 24 hours curing, the wooden frame was taken off the test-pit as shown in Photos 13 through 15. As these photos show, the voids were large, and the grout was unable to fill most of them. Also, as shown in Photo 14, most of the grout settled at the top of the coarse aggregate filter. Similar observations were seen throughout the cross section.



Photo 9 Grout Alongside the Form Wall



Photo 10 Grout Fell to the Bottom of the Voids



Photo 11 Elbow Tube Used to Deliver Grout



Photo 12 Final Grouting



Photo 13 Exposed PGR After 24 hours



Photo 14 Grout Settlement at the Bottom



Photo 15 Unfilled Voids

Based on the learned experience from the construction of the proposed test-pit, the following are recommended for future test-pits:

1. To eliminate the four walls confinement of the test-pit and to represent the actual site condition, the test-pit should have one 12'-0" long wall that will represent the wall of an abutment or pier and a surface area of 48 square feet.
2. The rock size must follow the size and gradation standards of specification Section 850.2 (a) 2. Larger rocks should be removed from the pile. A site visit to the quarry must be done before final approval of the rocks' size and gradation.
3. The grout pump should be cleaned thoroughly before pumping and a double screen should be used on top of the hopper to screen out large pieces of stone.
4. The grout pump should include a way to regulate the delivery flow so that it can be determined how much grout is in the voids.
5. For the delivery of grout into the rock's voids, use a straight tube in conjunction with an elbow tube to easily maneuver grout delivery.

#### 4.5 CONSTRUCTION OF PGR SCOUR COUNTERMEASURE AT PENNDOT BRIDGE SR 2028

On August 28, 2017 the Contractor started construction at bridge SR 2028. The Contractor worked on installing compost filter and other E&S control measures as shown on the plan. While the Contractor worked on locating the gas main line, they accidentally damaged a small section of the gas main line downstream and work came to a halt for two months. During that time, the original E&S plans went through various revisions. Due to the close proximity of the gas main line to upstream and downstream near abutment wingwall of span 1, and the location of scour holes, the PGR around the end of the near abutment wingwall was eliminated. Further, since the flow was mostly directed to Span 1 due to misalignment of the upstream channel with the bridge opening and constant sediment built up in Span 2, the District 6-0 Bridge engineer, decided to eliminate

PGR in Span 2 based on their engineering judgement and the knowledge that Span 2 was constantly blocked by sediment build up that would prevent flow of water into Span 2. As a result, the dimensions of the PGR were reduced to one span. Also, the temporary stream diversion devices were replaced by a bypass pumping system. The construction of PGR at bridge SR 2028 started on November 10, 2017 and was completed on December 18, 2017. The estimated cost of constructing PGR countermeasure at Bridge SR2028 was \$209,784.00. The breakdown of the estimated cost is presented in Table 10.

<b>Table 10 Modified Estimated Construction Cost of PGR Scour Countermeasure</b>					
<b>Item</b>	<b>Description</b>	<b>Quantity</b>	<b>Unit</b>	<b>Unit Price</b>	<b>Total Price</b>
0201-0001	CLEARING AND GRUBBING	1	LS	-	\$15,000.00
0203-0001	CLASS 1 EXCAVATION	311	CY	\$50.00	\$15,550.00
0212-0014	GEOTEXTILE, CLASS 4, TYPE A	218	SY	\$5.50	\$1,199.00
0608-0001	MOBILIZATION	1	LS	\$50,000.00	\$50,000.00
0703-0025	NO. 57 COARSE AGGREGATE	31	CY	\$65.00	\$2,015.00
4703-0025	NO. 57 COARSE AGGREGATE, MODIFIED	11	CY	\$120.00	\$1,320.00
0803-0001	PLACING STOCKPILED TOPSOIL	65	CY	\$65.00	\$4,225.00
0811-0003	TEMPORARY PROTECTIVE FENCE	70	LF	\$12.00	\$840.00
0845-0001	UNFORESEEN WATER POLLUTION CONTROL	5000	DOLLA	\$1.00	\$5,000.00
0849-0010	ROCK CONSTRUCTION ENTRANCE	2	EA	\$2,250.00	\$4,500.00
0850-0033	ROCK, CLASS R-5	3	CY	\$220.00	\$660.00
0850-0034	ROCK, CLASS R-6	147	CY	\$150.00	\$22,050.00
0855-0003	PUMPED WATER FILTER BAG	1	EA	\$1,000.00	\$1,000.00
0855-0004	REPLACEMENT PUMPED WATER FILTER BAG	1	EA	\$550.00	\$550.00
0867-0018	COMPOST FILTER SOCK, 18" DIAMETER	140	LF	\$17.50	\$2,450.00
0868-0100	COMPOST BLANKET - SEEDDED WITH FORMULA B	310	SY	\$7.50	\$2,325.00
0868-0104	COMPOST BLANKET - SEEDDED WITH FORMULA L	175	SY	\$8.00	\$1,400.00
0901-0001	MAINTENANCE AND PROTECTION OF TRAFFIC DURING	1	LS	-	\$20,000.00
9000-0001	TEMPORARY STREAM DIVERSION SYSTEM	1	LS	-	\$40,000.00
9000-0002	PARTIALLY GROUTING OF RIPRAP	30	CY	\$600.00	\$18,000.00
9000-5000	CONCRETE WASHOUT	1	EA	\$1,700.00	\$1,700.00
<b>TOTAL PROJECT COST</b>					<b>\$209,784.00</b>

PGR was installed (in dry condition) in two phases. In Phase 1, per revised E&S plan shown in Figure 7, compost filter socks were installed, and the work area was cleared and grubbed. For site access, rock construction entrance was constructed upstream on side of the right abutment (looking downstream) as shown in Photo 16. Upstream and downstream cofferdams were installed as shown in Photos 17a and 17b. Downstream after the cofferdam, an energy dissipater was installed as shown in Photo 18. A pump water filter bag was also installed downstream of temporary dam as shown in Photo 19. A bypass pumping system was installed as shown in Figure 7. The pump discharge pipe ran along Span 2 as shown in Photo 20 and discharged onto the energy dissipater (Photo 19). An 8-inch pump and a 6-inch backup pump were installed upstream as shown in Photo 21. In order to work in Span 1 in a dry condition the construction area between the upstream and downstream cofferdam was dewatered as shown in Photo 22.



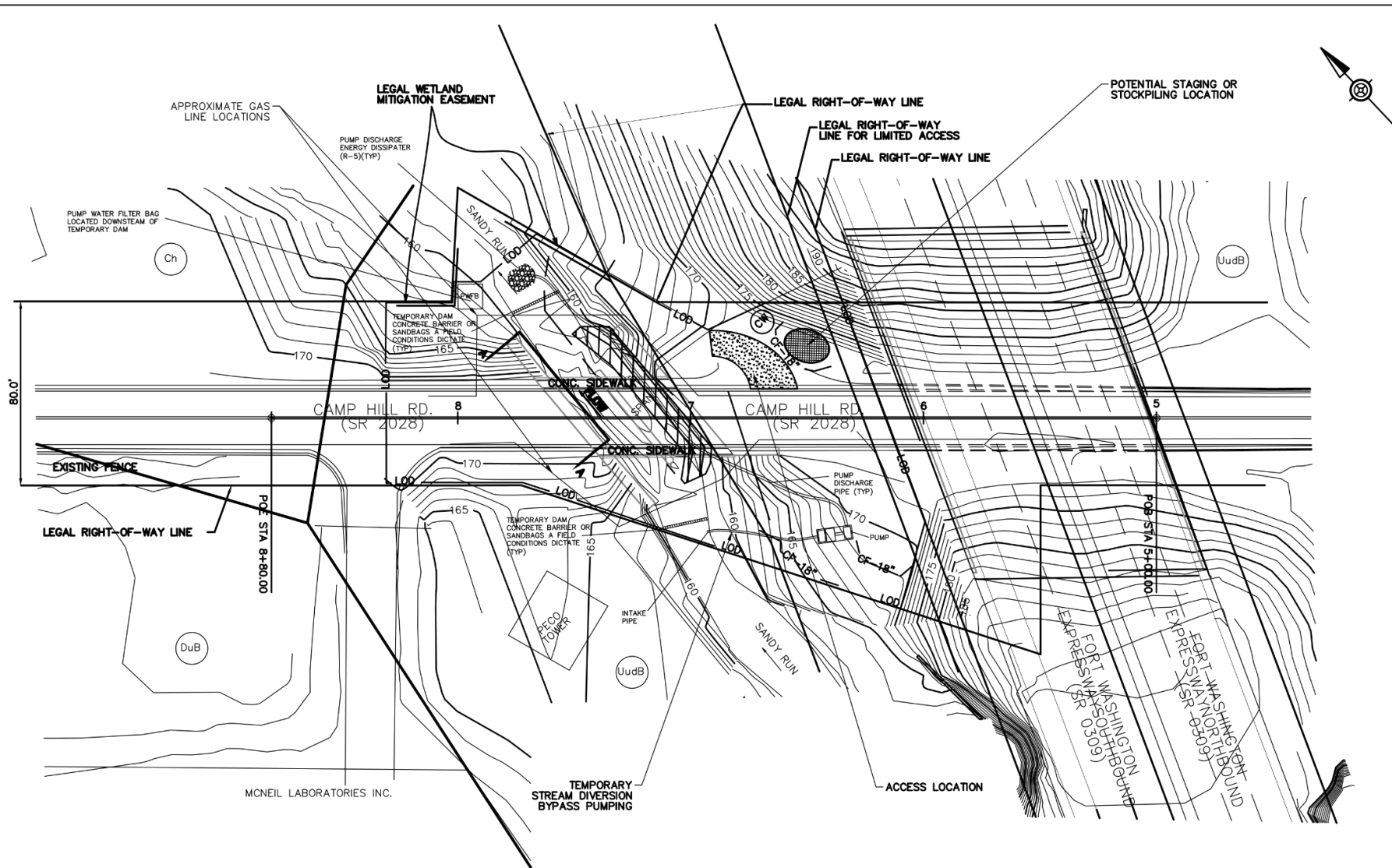



DISTRICT	COUNTY	ROUTE	SECTION	SHEET
6-0	MONTGOMERY	202B	PGR	9 OF 10
WHITEMARSH TOWNSHIP				
REVISION NUMBER	REVISIONS	DATE	BY	



**NOTES**

1. PHASE 1 EXCAVATION TO OCCUR WITHIN DESIGNATED AREAS ONLY.
2. PUMP AS REQUIRED TO MAINTAIN DRY WORK AREAS. PUMP WATER FROM WORK AREAS MUST BE DISCHARGED THROUGH A SEDIMENT CONTROL DEVICE SUCH AS A PUMPED WATER FILTER BAG.
3. TEMPORARY PROTECTIVE FENCING SHALL BE PLACED ALONG WETLAND MITIGATION LIMITS DOWNSTREAM OF THE BRIDGE TO PREVENT ACCESS TO THE RESTRICTED AREA.
4. MAINTAIN 5' MINIMUM CLEARANCE FROM EXISTING GAS LINES.

**LEGEND**

-  PHASE 1 EXCAVATION AREA
-  -LOD- LIMIT OF DISTURBANCE
-  -CF-18" - 18" DIA. COMPOST FILTER SOCK
-  - X - TEMPORARY PROTECTIVE FENCE
-  COMPOST SOCK CONCRETE WASHOUT
-  SOIL TYPE AND BOUNDARY

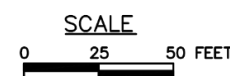

**PHASE 1  
EROSION AND SEDIMENT  
CONTROL PLAN**

**Figure 7 Modified E&S Sequence of Construction – Phase 1**



Photo 16 Upstream Construction Entrance



Photo 17a Upstream Cofferdam



Photo 17b Downstream Cofferdam



Photo 18 Downstream Energy Dissipater



Photo 19 Water Filter Bag



Photo 20 Pump discharge pipe in Span 2



Photo 21 Water Pumps



Photo 22 Preconstruction Condition of Span 1

In Phase 2, per revised E&S plan shown in Figure 8, construction of PGR was done in-the-dry. Due to the height and location of the bridge, equipment accessibility and maneuverability were very limited and time consuming, slowing productivity. Access to Span 1 was made from the upstream right bank area. Two track excavators were used to transfer the material under Span 1. One large track excavator was positioned on the upstream bank while a mini track excavator was positioned on the dry stream as shown in Photo 23. Existing rocks and sediments were removed from Span 1 as shown (Photo 24) and at the pier-nose using the mini track excavator. Some of the sediments were stockpiled downstream for later use. Prior to excavation the streambed in Span 1 as well as Upstream/and Downstream bed were surveyed to determine streambed elevations. Due to the track movement of the mini excavator, the level base became unstable. To stabilize the level base a layer of AASHTO Number 1 coarse aggregate was placed as shown in Photo 25. Excavation at abutment and pier of Span 1 were done to achieve subgrade elevation. Additional excavation was done to achieve the low flow channel subgrade elevation. Starting from downstream and moving upstream, a 2-inch layer of AASHTO Number 57 coarse aggregate was placed to level subgrade base as shown in Photo 26. A combined filter was installed by placing Geotextile Class 4, Type A, with a layer of 6-inches of AASHTO Number 57 coarse aggregate on top of the 2-inch layer of coarse aggregate as shown in Photo 27. The R6 rocks were stockpiled at the site.

An attempt was made to prewash the rocks to remove excessive silt. The prewashing of the rocks was ineffective due to site limitation and while the front-loader operator moved the washed rocks from the stockpile, the rocks were again contaminated with silt. Furthermore, the quarry made substantial effort to deliver clean rocks. Thus, the rocks were not prewashed. A layer of minimum thickness of 24 inch of R6 rock was placed on top of the combined filter as shown in Photo 28. After the R6 rocks were placed, they were power washed to remove excess dirt and material from their surface and to ensure adherence of grout to rock faces. Using a grout pump with 2-inch diameter hose with a modified grout end delivery as shown in Photo 29, the grout was placed in a zig-zag grout technique in the void to fill approximately one-third to one-half the void spaces as shown in Photo 30.

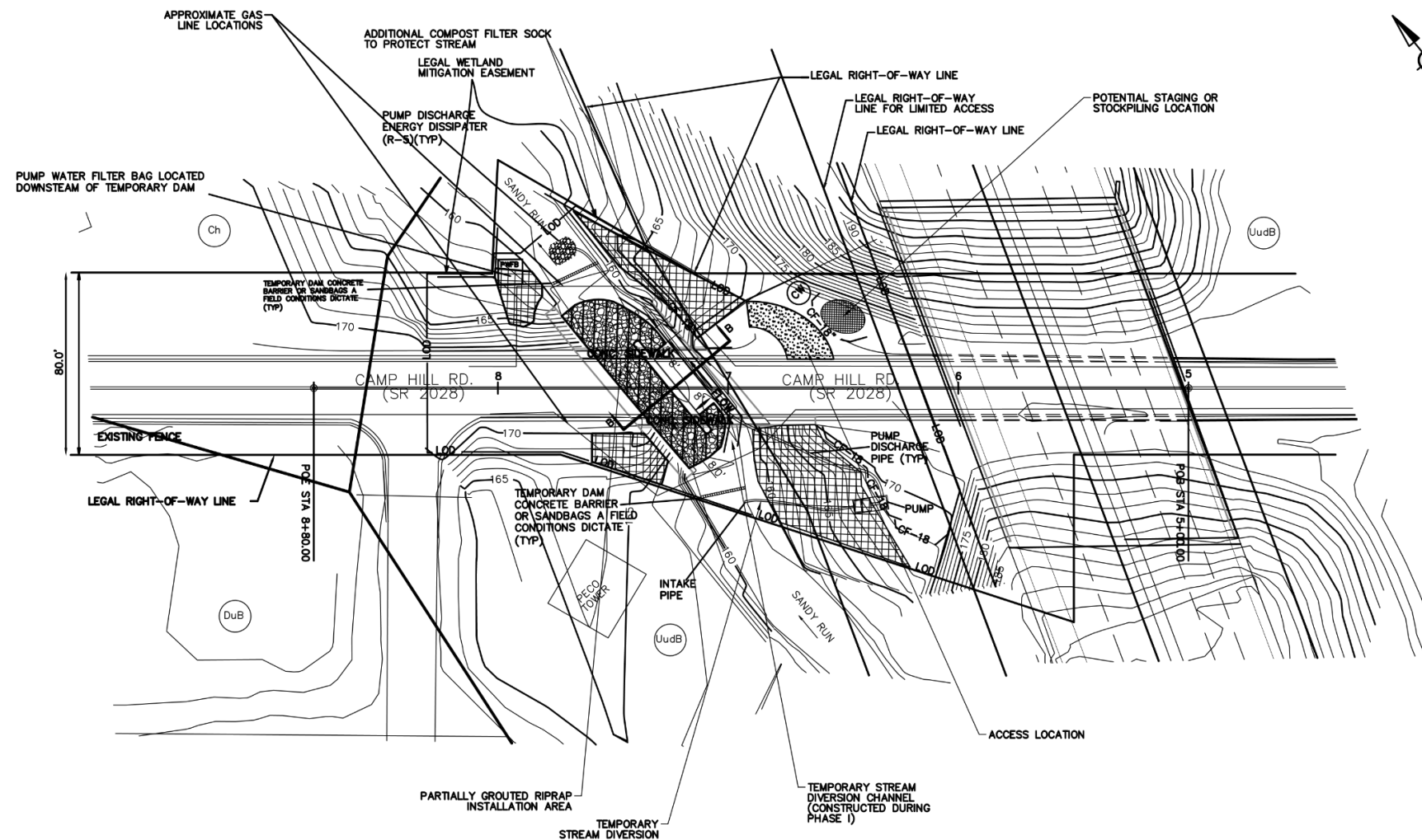

Photo 23 Large and Mini Track Excavators



Photo 24 Removal of Existing Rocks in Span 1

DISTRICT	COUNTY	ROUTE	SECTION	SHEET
6-0	MONTGOMERY	2028	PGR	10 OF 11
WHITEMARSH TOWNSHIP				
REVISION NUMBER	REVISIONS	DATE	BY	



**NOTES**

1. PUMP WORK AREA AS REQUIRED TO MAINTAIN DRY WORK AREAS. PUMPED WATER FROM WORK AREAS MUST BE DISCHARGED THROUGH A SEDIMENT CONTROL DEVICE SUCH AS A PUMPED WATER FILTER BAG.
2. TEMPORARY CONSTRUCTION FENCING SHALL BE PLACED ALONG WETLAND MITIGATION LIMITS DOWNSTREAM OF THE BRIDGE TO PREVENT ACCESS TO THE RESTRICTED AREA.
3. ADJUST AND INSTALL ADDITIONAL COMPOST FILTER SOCK AS REQUIRED FOR PHASE 2.
4. INSTALL PARTIALLY GROUTED RIP RAP IN DESIGNATED AREA IN THE DRY CONDITION.
5. MAINTAIN 5' MINIMUM CLEARANCE FROM EXISTING GAS LINES.

**LEGEND**

- PHASE 2 EXCAVATION AREA
- LOD- LIMIT OF DISTURBANCE
- CF-18" - 18" DIA. COMPOST FILTER SOCK
- X - TEMPORARY PROTECTIVE FENCE
- EROSION CONTROL BLANKET
- PARTIALLY GROUTED RIPRAP
- COMPOST SOCK CONCRETE WASHOUT
- CF-18" - 18" DIA. COMPOST FILTER SOCK
- SOIL TYPE AND BOUNDARY

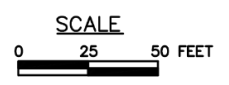

**PHASE 2  
EROSION AND SEDIMENT  
CONTROL PLAN**

**Figure 8 Modified E&S Sequence of Construction – Phase2**



Photo 25 Placing AASHTO Number 1 Course Aggregate



Photo 26 Placing 2-inch of AASHTO No 57 to Level Base



Photo 27 Placement of Combined Filter



Photo 28 Placement of R6 Rocks on Top of Combined Filter



Photo 29: Modified Grout End Delivery



Photo 30: Placing Grout in Voids

Grout was also placed along the immediate interface between the rocks and piers/abutments as shown in Photo 31. After 24 hours of grout placement, the stockpile of natural streambed material was placed on top of PGR to the depth indicated on the design plan and as shown in Photo 32. The streambed in Span 2 was regraded to the depth indicated on the design plan with a low flow channel as shown in Photo 33. The final streambed elevations of the completed PGR work were verified using the documented streambed elevations prior to excavation. Finally, all temporary stream diversion devices were removed. All E&S control measures were also removed after all

areas had been stabilized, and the water was allowed to flow back onto the original streambed through Span 1 and 2 as shown in Photo 34.



Photo 31 Grout Placement at Interface



Photo 32 6-inches of Streambed Material Placed on Top of PGR



Photo 33 Regraded Streambed with Low Channel in Span 2



Photo 34 Post Construction of PGR

As reported by the contractor under Force Account Agreement, the actual cost of PGR scour countermeasure construction at bridge SR 2028 was \$209,784.00 without the Test-Pit construction and was \$226,121.99.76 with the Test-Pit construction. Table 11 shows the comparison between the estimated and actual construction cost of PGR scour countermeasures at bridge SR 2028. The contractor did not provide a cost-per-item number but a lump-sum amount that reflected the work period. Based on observation of construction, an attempt was made to relate each work period (actual) to item number as shown in Table 11. The overall comparison between the estimated and actual cost of PGR construction at the bridge SR 2028 site was very close. However, the comparison between lump-sum for each period of work and the item period

for that lump-sum was not conclusive. This is expected because the construction was done under Force Account Agreement where the contractor did not have to itemize the construction process.

<b>Table 11 Comparison Between Estimated and Actual Construction Cost of PGR Scour Countermeasure at Bridge SR 2028</b>				
<b>Item Number</b>	<b>Description</b>	<b>Estimated</b>	<b>Actual</b>	
0201-0001	Clearing and Grubbing	\$15,000.00	\$16,083.58	
0608-0001	Mobilization, Gas Main, Clearing	\$50,000.00		
0901-0001	Maintenance and Protection of Traffic During Construction	\$20,000.00		
	<b>Subtotal</b>	<b>\$85,000.00</b>	<b>\$16,083.58</b>	
0203-0001	Class 1 Excavation	\$15,550.00	\$99,065.35	
0811-0003	Temporary Protective Fence	\$840.00		
0849-0010	Rock Construction Entrance	\$4,500.00		
0850-0033	Rock, Class R-5	\$660.00		
0855-0003	Pumped Water Filter Bag	\$1,000.00		
0855-0004	Replacement Pumped Water Filter Bag	\$550.00		
0867-0018	Compost Filter, 18" Diameter	\$2,450.00		
9000-0001	Temporary Stream Diversion System	\$40,000.00		
	<b>Subtotal</b>	<b>\$65,550.00</b>		<b>\$99,065.35</b>
0212-0014	Geotextile, Class 4, Type A	\$1,199.00		\$93,074.20
0703-0025	No. 57 Coarse Aggregate	\$2,015.00		
4703-0025	No. 57 Coarse Aggregate, Modified	\$1,320.00		
0803-0001	Placing stockpiled Topsoil	\$4,225.00		
0845-0001	Unforeseen Water Pollution Control	\$5,000.00		
0850-0034	Rock, Class R-6	\$22,050.00		
0868-0100	Compost Vblanket-Seeded With Formula B	\$2,325.00		
0868-0104	Compost Vblanket-Seeded With Formula L	\$1,400.00		
9000-0002	Partially Grouting of Riprap	\$18,000.00		
9000-0005	Concrete washout	\$1,700.00		
	<b>Subtotal</b>	<b>\$59,234.00</b>	<b>\$93,074.20</b>	
	Test Pit		\$17,898.63	
	<b>Subtotal Without Test Pit</b>	<b>\$209,784.00</b>	<b>\$208,223.13</b>	
	<b>Total with Test Pit</b>		<b>\$226,121.76</b>	

#### 4.5.1 ENVIRONMENT TESTING AND MONITORING OF PGR CONSTRUCTION AT BRIDGE SR 2028

It was necessary to protect the environment surrounding the construction of PGR at bridge SR 2028. In addition to utilizing bypass pumping, the dewatering effluent within Span 1 and 2 were emptied into a large water filter bag located downstream which vented and allowed to flow back into the stream. The entire construction area was enclosed by composite filter socks and other E&S measures.

Water quality was monitored before, during, and after the construction of the PGR. Water quality parameters monitored were pH, temperature, and turbidity. Based on research done by Fitch (2003) and Lagasse et.al (NCHRP Report 593), pH is the only water quality parameter that is expected to change significantly during grout placement.

The YSI Model 63 handheld pH, Conductivity, Salinity, and Temperature System shown in Photo 35 was used to measure pH and temperature at upstream intake of the pump as shown in Photo 17a and downstream after the pump discharge energy dissipater as shown in Photo 18. LaMotte 2020 we/wi Turbidimeter meter as shown in Photo 36 was used to measure turbidity at the upstream intake of the pump and downstream after the pump discharge energy dissipater.



Photo 35 YSI Model 63



Photo 36 LaMotte we/wi Turbidimeter

Results from pH testing before, during, and after the construction of PGR at bridge SR 2028 is shown in Figure 9. The upstream and downstream follow the same trend. The pH level for upstream and downstream ranged from 6.89 to 8.32. The high pH level in the downstream is attributed to the discharge from the water filter bag located downstream. On December 7, 2017, during the placement of rocks, it was observed that the level of the stream at the pump intake was unexpectedly high at 1:00 pm and it is believed to be due to discharge of water at further distance upstream. During that time the level of pH spiked at 1:00 pm as shown in Figure 9 and returned to normal at 2:30 pm. It was believed to be due to the sudden discharge of water further upstream. Partial grouting of the riprap started at 9:00 am on December 11, 2017. As shown in Figure 9 the pH level downstream increased up to 7.97 with an average of 0.8 higher than upstream. After grouting was completed at 1:30, the pH level returned to normal.

Results from turbidity testing before, during, and after the construction of PGR at bridge SR 2028 is shown in Figure 10. Upstream turbidity was between 0.2 and 1.0 nephelometric turbidity units (NTUs). Turbidity downstream peaked at 7.42, 79.77, and 18.8 NTUs during bypass pumping, excavation, and placement of filter and rocks, respectively. There was no increase in turbidity during grouting as shown in Figure 10.

Results from temperature testing before, during, and after the construction of PGR bridge SR 2028 is shown in Figure 11. Upstream and downstream temperature was nearly the same throughout the construction period of PGR as shown in Figure 11.

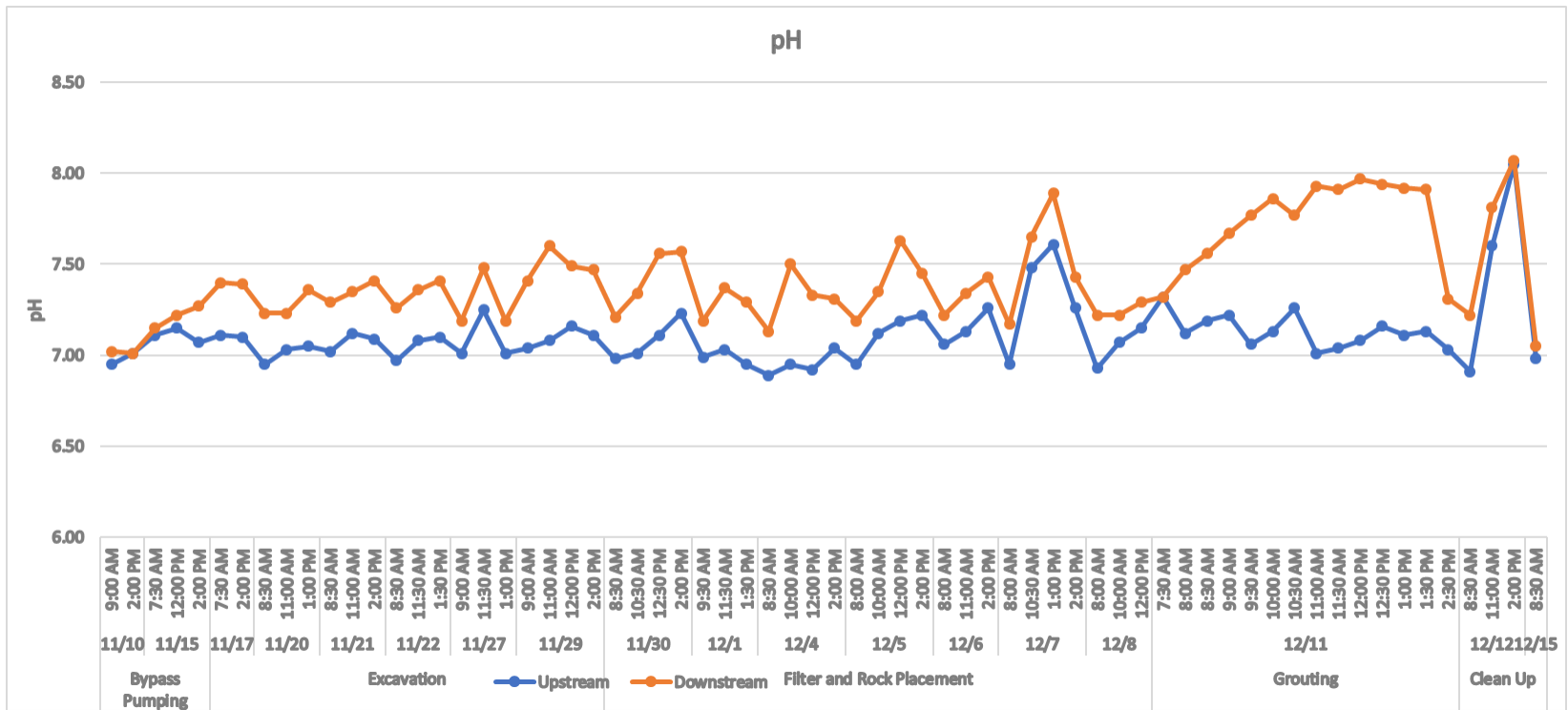

Figure 9: Results from pH Testing before, during, and after the construction of PGR at Bridge SR 2028

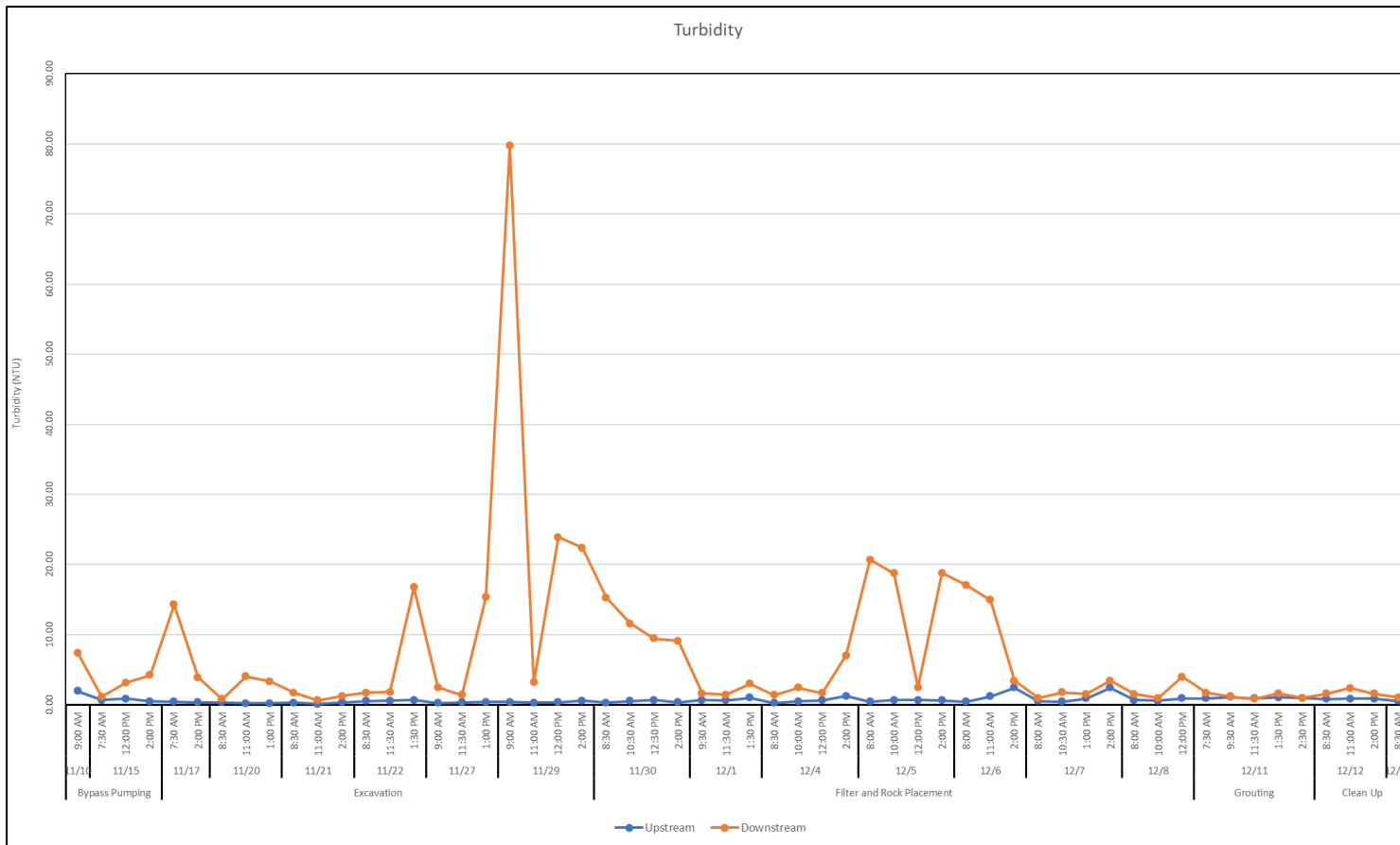

Figure 10: Results from turbidity Testing before, during, and after the construction of PGR at Bridge SR 2028

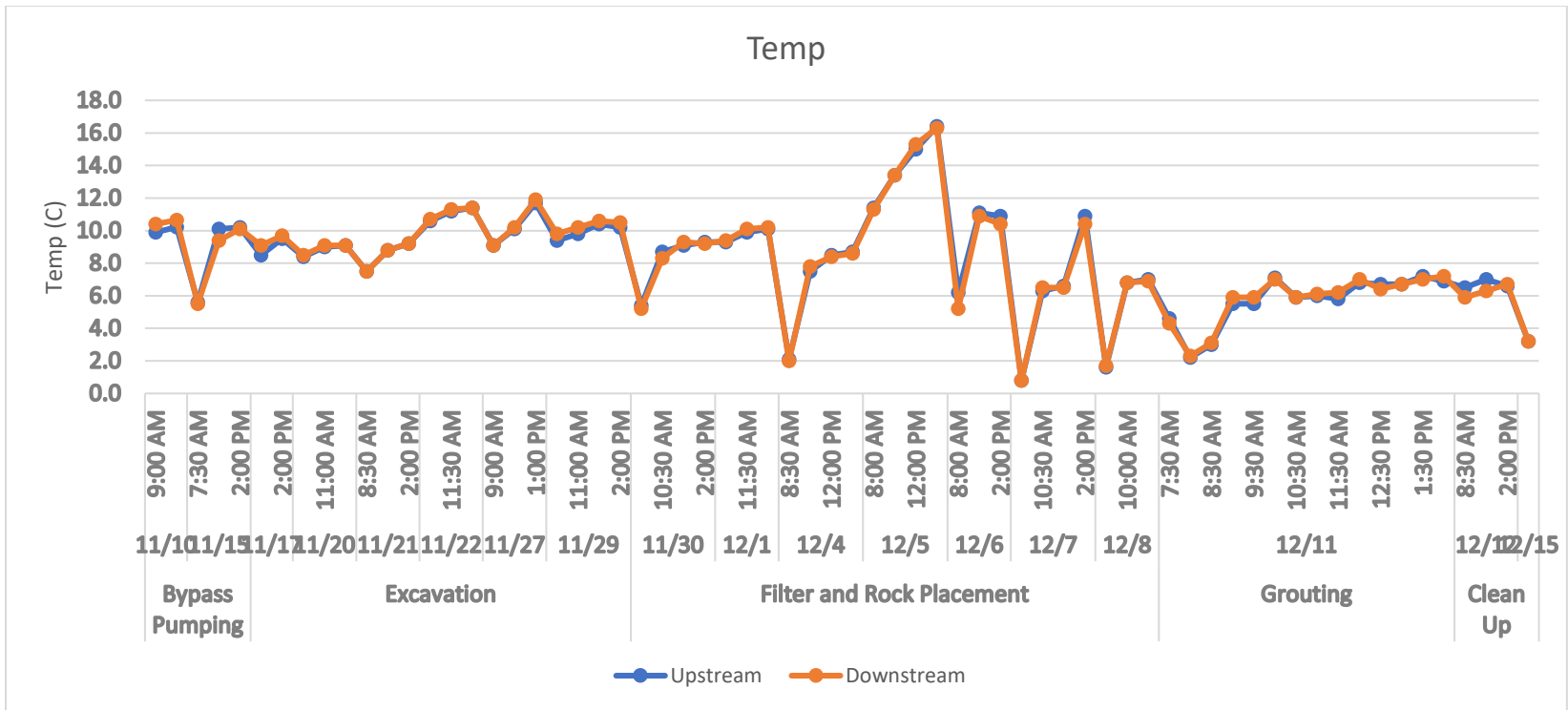

Figure 11: Temperature measurements before, during, and after the construction of PGR at Bridge SR 2028

#### 4.5.2 ON-SITE ASSESSMENT AFTER PGR CONSTRUCTION AT BRIDGE SR 2028 PIER AND ABUTMENT

The construction of PGR at bridge SR 2028 was completed on December 18, 2017 and the condition of the constructed PGR as a scour countermeasure at bridge SR 2028 was evaluated visually by two site assessments conducted by the Temple research team on March 26, 2019 and September 7, 2019. Additionally, as mandated by FHWA PennDOT District 6-0 conducted two-year cycle of NBIS Bridge Inspection on October 9, 2018.

During the first on-site assessment (March 26, 2018) an underwater video as well as pictures were taken to document the condition of PGR. The underwater video footage is attached to this report. Additionally, a visual inspection of the downstream condition was done to determine if there were any dislodged rocks in and around the PGR. No rocks were observed to be dislodged as confirmed by inspecting the PGR in Span 1. Photo 37 and 38 show the upstream and downstream view of bridge SR 2028 before and after construction, respectively. As can be seen from Photo 37 and 38, the stream was flowing freely through Span 1 and 2, and the stream started to return to its original condition. The water depth in Span 1 at the pier/abutment side was approximately 15 inches whereas the depth of water at the low-flow-channel was approximately 32 inches. The water depth at Span 2 was approximately 15 inches. It appears that the 6 inches of placed sediment on top of the PGR at the pier and abutment side has eroded in some locations. This is especially true in the middle of the longitudinal length of Span 1 as shown in Photo 39 and 40. However, the 6 inches of placed sediments at the low-flow channel remain intact with no evidence of erosion as shown in Photo 41. Similar observations were seen upstream and downstream of the pier and abutment side. It should be noted that there was no evidence of erosion in Span 2. Further, it seems that aquatic life has rebounded close to its original state in and around the PGR location. Some fishes as well as filamentous algae growth could be seen on top of the PGR as shown in Photo and 42.



Before Construction

After Construction

Photo 37 Upstream View at Bridge SR 2028



Before Construction



After Construction

Photo 38 Downstream View at Bridge SR 2028



Photo 39 Under Water View of PGR at Abutment side

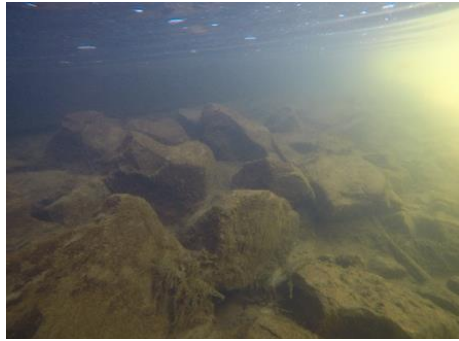

Photo 40 Under Water of PGR at Pier side



Photo 41 Under Water View of Low-Flow Channel



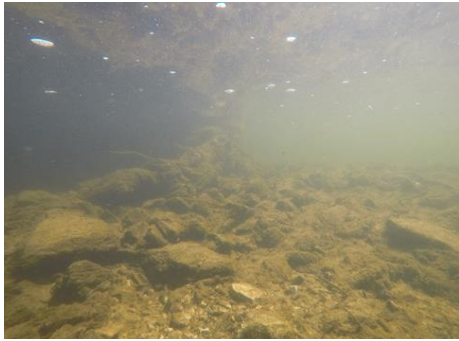

Photo 42 Filamentous Algae Growth on Top of PGR

During the second on-site assessment (September 7, 2018) after PGR construction at bridge SR 2028, underwater video and pictures were taken to document the condition of PGR. The underwater footage is attached to this report. Additionally, a visual inspection of the downstream condition was done to determine if there were any dislodged rocks in and around the PGR. During inspection of Span 1, it was confirmed that no rocks were observed to be dislodged from the PGR. Photo 43 and 44 show the upstream and downstream view of bridge SR 2028 during the first and second on-site assessments, respectively. As can be seen from Photo 43 and 44, the stream was flowing freely through Span 1 and 2 returning to its original condition. Vegetation naturally returned to the areas that were disturbed by construction. Debris at upstream of Pier nose crossing to Span 1 were observed and shown in Photo 45. Sediment and debris buildup downstream of Span 2 were observed and shown in Photo 46. The return of sediment built-up at downstream of Span 2 confirmed the assumption made by District 6-0 Bridge Engineer that sediment built-up would prevent flow of water in Span 2, and further substantiate the decision to eliminate PGR in Span 2.



First On-Site Inspection



Second On-Site Inspection

Photo 43 Upstream View at SR 2028



First On-Site Inspection



Second On-Site Inspection

Photo 44 Downstream View at SR 2028



Photo 45 Debris at Upstream of Pier Nose and Span 1



Photo 46 Sediments Built-up and Debris in Downstream of Span 2

The water depth in Span 1 and Span 2 is shown in Figure 12. The average water depth at the pier/abutment side of Span 1 was approximately 10 inches whereas the depth of water at the low-flow-channel of Span 1 was approximately 25 inches (location number 2, 5, and 8). The average water depth at the abutment side of Span 2 was approximately 6 inches (location number 18, 15, and 12). Whereas, the average water depth at the upstream and downstream of Span 2 at the pier side was 9.5 inches (location number 16 and 10) and at location number 13 was 3 inches indicating

sediment buildup. The water depth at location number 11 and 14 was 21.5 inches and 14.5 inches, respectively, indicating streambed erosion at the upstream of Span 2 and the development of scour holes at these locations.

It appears that the 6 inches of sediment on top of PGR at the Pier/abutment side of Span 1 has eroded as shown in Photos 47, 48, and 49. However, the 6 inches of sediment at the low-flow channel remain intact with no evidence of erosion. Furthermore, it appears that aquatic life has rebounded close to its original state in and around the PGR as fish and filamentous algae growth could be seen.

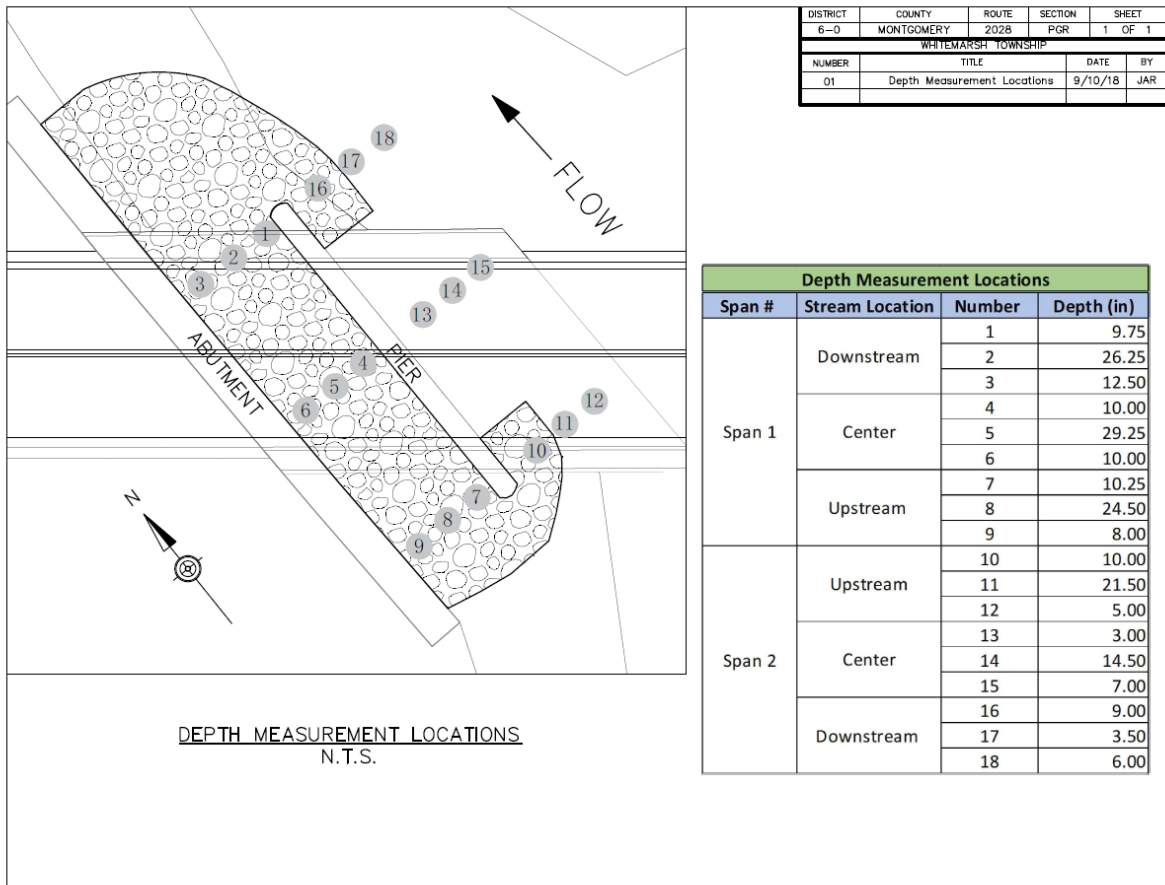
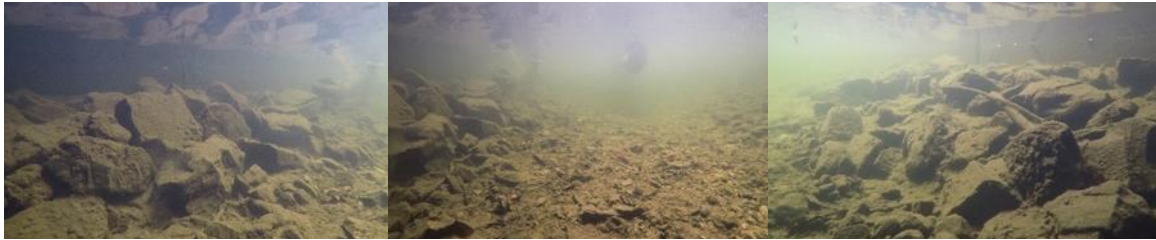

Figure 12 Water Depth at Bridge SR 2028



Location Number 9

Location Number 8

Location Number 7

Photo 47 Under Water View of PGR at Upstream of Span 1



Location Number 6

Location Number 5

Location Number 4

Photo 48 Under Water View of PGR at Middle of Span 1



Location Number 3

Location Number 2

Location Number 1

Photo 49 Under Water View of PGR at Downstream of Span 1

As mandated by FHWA, a subcontractor of PennDOT District 6-0 conducted a two-year cycle of NBIS Bridge Inspection (District Inspection) on October 9, 2018. The District Inspection report, generally, agreed with the Temple research team assessments, except for a disagreement on the scour condition of Span 2. The District Inspection report indicated that there is advanced scour along the far abutment and minor scour along the center, far face of Pier 1. The pier and far abutment footings were detected 1.8 feet below the water line through silt and sand. Based on PennDOT Pub # 100A (2018 edition), IN05 Scour Hole (SC), Scour Definition Diagram, the reported classification of “Advance Scour” is within PennDOT classification. Therefore, bridge SR 2028 is designated as scour critical. The author of this report raised a concern when comparing previous PennDOT inspection reports to findings in the most recent inspection reports, as there was no recordable receding of the streambed as shown in Table 12 and Photo 50, which indicates there

is no scour present. Additionally, the intended design of the scour countermeasure for bridge SR 2028 was to direct all the water flow into Span 1 due to miss alignment of the upstream channel with the bridge opening and the constant sediment built up in Span 2 that would prevent water flow through Span 2. The observed scouring of the streambed in Span 2 and the sediment built-up in Span 2 after one year of completing the PGR construction should not be used to define the scour condition of bridge SR 2028. Furthermore, there is no scour in Span 1, bridge SR 2028 should be classified as non-scour critical due to implementation of PGR as a permanent scour countermeasure.



Photo 50 Cross-Section of the Streambed in Span 2

**Table 12 Summary of Inspection Reports**

Inspection/Item	11/30/2010	11/16/2012	10/14/2014	10/11/2016	Construction 11/10/2017 - 12/18/2017	Site Assessment 3/26/2018	Site Assessment 9/7/2018	10/9/2018
Channel	<p>Advanced scour is exposing the footing of the near abutment and pier 1. The banks are typically eroded 2' to 5' above the water surface, along the edge of water. Exposed and undermined roots are present on the near right embankment. There is knocked down vegetation, indicating that the banks overtop in high flow. The channel has migrated towards the near abutment and a large sediment deposit is restricting flow through span 1 (80 C.Y.). There are also moderate accumulations of miscellaneous and timber debris in the channel (1 C.Y.). The alignment flows impacts near the right wing wall.</p>	<p>The near abutment is encroaching on the channel. During normal flow conditions the channel is directed into the near right wingwall and through span 1. Span 2 is blocked by a sediment deposit. Advanced scour has exposed the footings at the near abutment and pier.</p>	<p>POOR – The majority of the flow passes through Span 1 and impacts the near right wingwall. There is sediment deposit under Span 2 and a scour hole up to 2.3' deep under Span 1. Advanced scour is present for the full length of the pier and minor scour exists at the near abutment. Rock protection has been placed in front of the near abutment and near side of the pier since the previous inspection. The top of the footing is exposed and can be probed through the streambed on the far side. All channel banks have scour up to 5' high.</p>	<p>POOR - The flow passes through Span 1 and impacts the free end of the BUILT-UP near right wingwall. There is no flow through Span 2 due to sediment deposits and timber debris accumulation at the upstream end of the pier. There is advanced scour along both sides of the pier and minor scour at the near abutment. The pier footing is exposed up to 0.2' high along the near side and the top of the footing is detected through the streambed along the far side. Rock protection is in place along the near abutment and along the near side of the pier. All channel banks have scour from 2' to 5' high.</p>	See Section 4.5 above	See Section 4.5.2 above	See Section 4.5.2 above	<p>POOR - Channel flow passes through Spans 1 and 2 with flow impacting the free end of the near right wingwall. The sediment deposits blocking flow into span 2 including the timber debris at the upstream nose of the pier have been removed since the previous 10/2016 inspection. Minor timber debris remains at the upstream pier nose. There is advanced scour along the far abutment and minor scour along the center, far face of pier 1. The pier and far abutment footings were detected 1.8' below the water line through silt and sand. Partially grouted riprap (PGR) paving has been installed under span 1 since the previous 10/2016 inspection. The PGR protection is located along the near abutment and the near side of the pier, continuing around the pier noses, and partially on the far side of the pier at the ends. All</p>

									channel banks have scour from 2' to 5' high.	
Maintenance Recommendation			B745301 - Construct rock protection - (Priority 2); C74530 I - Backfill scour hole - (Priority 2); ECREMDP - Remove deposits - (Priority 3); ECREMVG - Remove vegetation and debris- (Priority 3)	B745301 - Install rock protection along the near abutment, pier and upstream channel- (Priority 2); C745301 - Backfill the scour hole under span 1 - (Priority 2); ECREMDP - Remove sediment deposits under span 2 and upstream - (Priority 3); ECREMVG-Remove the debris in the channel- (Priority 3).	B745301: Place rip-rap rock protection at the pier. (Priority 2); C745301: Backfill the scour hole in Span 1. (Priority 2); ECREMDP: Remove the sediment deposits in Span 2 and upstream. (Priority 3); ECREMVG: Remove the channel debris. (Priority 3);	B745301: Place rip-rap rock protection along the pier. (Priority 2); C745301: Backfill the scour hole in Span 1. (Priority 2); ECREMVG: Remove the timber debris at the upstream of the pier. (Priority 2); ECREMDP: Remove the sediment deposits in Span 2, upstream and downstream. (Priority 3)	See Section 4.5 above	See Section 4.5.2 above	See Section 4.5.2 above	B745301: Place riprap protection along the far abutment and at the far face of pier 1 (Priority 2); ECREMDP: Remove the sediment deposits in Span 2, upstream and downstream. (Priority 3); ECREMVG: Remove the timber debris at the upstream of the pier. (Priority 3);
Substructure 1A02	Near Abutment (NAB)	Wings	right - 2 C.Y. erosion at end of win	right - 2 CY erosion at end of wing	WNR has erosion (2 CY) at end of wall.	WNR has erosion (2 CY) at end of wall.	See Section 4.5 above	See Section 4.5.2 above	See Section 4.5.2 above	WNR has erosion (2 CY) at end of wall.
		Footing	exposed full length at 1.8' below water surface, 1.2' maximum vertical exposure from mid abut to right	exposed full length at 1.8' below water surface, 1.5' maximum vertical exposure from mid abut to right corner	Previously noted full length exposed footing has been covered with placed rock since 10/2012 inspection.	Minor scour; Previously noted full length exposed footing has been covered with placed rock since 10/2012 inspection	See Section 4.5 above	See Section 4.5.2 above	See Section 4.5.2 above	No scour; Footing has been covered with PGR protection since the 10/2016 inspection.
		IN20 Scour Undermine	1 - Yes	1 -Yes	1 - Yes	1 - Yes	See Section 4.5 above	See Section 4.5.2 above	See Section 4.5.2 above	0 - No
		Settlement	Advanced scour, no settlement observed	Advanced scour, no settlement observed.	No settlement observed.	No settlement observed	See Section 4.5 above	See Section 4.5.2 above	See Section 4.5.2 above	No settlement observed
	Far Abutment	Wings	-	-						
		Footing	Not visible.	Not visible	Not visible, covered by silt and sand.	Not visible, covered by silt and sand.	See Section 4.5 above	See Section 4.5.2 above	See Section 4.5.2 above	Advanced scour; Footing detected full length of the stem at 1.8' below water line.

	(FAB)	IN20 Scour Undermine	0 - No	0 - No	0 - No	0 - No	See Section 4.5 above	See Section 4.5.2 above	See Section 4.5.2 above	1 - Yes
		Settlement	None observed	None observed.	No settlement observed.	No settlement observed				No settlement observed
Pier Details 5D02 Pier: P01		IN20 Scour Undermine	Yes	Yes	Yes	Yes	See Section 4.5 above	See Section 4.5.2 above	See Section 4.5.2 above	Yes
		Condition Summary	FOOT: exposed full length near and at upstream nose at 2.0' below water surface, 1.8' maximum vertical exposure; heavy scaling on far side.	FOOT: exposed full length near and at upstream nose at 2.3' below water surface, 2.7' maximum vertical exposure; heavy scaling on far side.	FOOTING (Concrete) - Previously noted full length exposed footing along near face and U/S nose has been covered with placed rock since 10/2012 inspection. Top of footing exposed above placed rock full length of near face. Top of footing along far face probed 2.0' below water level covered by silt and sand.	FOOTING (Concrete) - Previously noted full length exposed footing along near face and U/S nose has been covered with placed rock since 10/2012 inspection. Top of footing exposed full length of near face with up to 0.2' of vertical exposure. Top of footing along far face probed 2.0' below water level covered by silt and sand.	See Section 4.5 above	See Section 4.5.2 above	See Section 4.5.2 above	FOOTING (Concrete) - Previously noted full length exposed footing along near face and U/S nose has been covered with grouted placed rock since 10/2012 inspection.  PGR protection installed since the 10/2016 inspection along near side of the pier, continuing around the pier noses, and partially on the far side of the pier at the ends. Top of footing along far face was detected at the center by probing 1.8' below water level through silt and sand. (Assume this area is protected from further scour by partially grouted rock at both ends of the far face of the pier - consider as minor scour).
		Settlement	Advanced scour, no settlement observed.	Advanced scour, no settlement observed.	No settlement observed	No settlement observed				No settlement observed.
FAB IN24			No scour observed	No scour observed.	No scour observed	No scour observed.	See Section 4.5 above	See Section 4.5.2 above	See Section 4.5.2 above	Advanced scour - Far abutment footing top detected full length of the stem at 1.8' below

								the water line through silt.	
P01 IN24		Advanced scour - footing exposed at 2.0' below water surface with 1.8' of vertical exposure.	Advanced scour - footing exposed at 2.3' below water surface with 2.7' of vertical exposure.	Advanced scour - Newly placed rock along full length of near face and both pier noses; Top of footing exposed full length of near face. Top of footing along far face was detected by probing 2.0' below water level through silt and sand	Advanced scour - Placed rock along full length of near face and both pier noses; Top of footing exposed full length of near face with up to 0.2' of vertical exposure. Top of footing along far face was detected by probing 2.0' below water level through silt and sand.	See Section 4.5 above	See Section 4.5.2 above	See Section 4.5.2 above	Minor scour - PGR protection along full length of pier near face and at both pier noses and ends of far face; Top of footing not detected along near face; Previously footing exposed full length of near face with up to 0.2' of vertical exposure (10/11/16 inspection). Top of footing along far face was detected at the center by probing 1.8' below water level through silt and sand. (Assume this area is protected from further scour by partially grouted rock at both ends of the far face of the pier - consider as minor scour)..
NAB IN24		Advanced scour - footing exposed at 1.8' below water surface; max vertical exposure of 1.2'	Advanced scour - footing exposed at 1.8' below water surface; max vertical exposure of 1.5'.	Minor scour - Newly placed rock along full length of NAB; Footing is not visible.	Minor scour - Placed rock along full length of NAB; Footing is not visible.	See Section 4.5 above	See Section 4.5.2 above	See Section 4.5.2 above	No scour - PGR protection along full length of NAB; Footing is not detected. Scour changed from Minor to None due to construction parameters include a new streambed elevation and the grouting of the entire channel under span 1.
	Channel	Advanced scour is exposing the footing of the near abutment and pier 1.	Advanced scour is exposing the footing of the near abutment and pier 1. Flow is through span 1 only. Span 2 has	Majority of flow is through Span 1 with minor flow through Span 2; Advanced scour full length of P1 and minor	Stream flows straight through Span 1 with scour up to 2.3' below the bridge; No flow	See Section 4.5 above	See Section 4.5.2 above	See Section 4.5.2 above	Stream flows straight through Spans 1 and 2 with scour up to 1.5' below the bridge; Previously noted

			partial sediment blockage and sediment bar at far right (upstream).	scour full length of NAB; Newly placed rock along full length of NAB and P1 near face; NAB footing is no longer exposed; P1 near face, the top of footing is exposed full length; P1 far face footing is detected by probing through silt and sand; Span 1 channel scoured up to 2.3' deep; Span 2 has partial sediment blockage and sediment deposit at FR (upstream).	through Span 2 due to 2' high of sediment deposit and debris accumulated at upstream end of Span 2; Advanced scour full length of P1 on near side exposes top of footing with placed rock protection; Minor scour full length of NAB, footing is not visible with placed rock protection. Footing of FAB and far side of P1 is not visible and detected through silt and sand.				sediment deposit blocking flow into span 2 and timber debris at the upstream nose has been removed.  PGR paving has been installed under Span 1 since the 10/2016 inspection. PGR protection installed along the full length of the near abutment and near face of pier 1, and both ends of the far face of pier 1. Minor scour is present at middle of pier at far face. Advanced scour is present along the full length of the far abutment; Footing was detected at 1.8' below the waterline through silt.
Channel 1A05	Banks	Typically eroded 2' to 5' above water surface along edge of water; exposed and undermined roots are present on the near right embankment; knocked down vegetation indicating that the banks overtop in high flow.  Channel has migrated towards the near abutment; large sediment	Typically eroded 2' to 5' above water surface along edge of water; exposed and undermined roots are present on the near right embankment; knocked down vegetation indicating that the banks overtop in high flow.	All banks have scour between 2' to 5' high; NR bank has exposed and undermined roots; Some vegetation along the banks are knocked down indicating that the banks overtop during high flow. The far upstream and downstream banks have vegetation roots undermined with up to 5' high scour.	All banks have scour between 2' to 5' high; NR bank has exposed and undermined roots; Some vegetation along the banks are knocked down indicating that the banks overtop during high flow. The far upstream and downstream banks have vegetation roots undermined with up to 5' high scour.	See Section 4.5 above	See Section 4.5.2 above	See Section 4.5.2 above	All banks have scour between 2' to 5' high; NR bank has exposed and undermined roots; Some vegetation along the banks are knocked down indicating that the banks overtop during high flow. The far upstream and downstream banks have vegetation roots undermined with up to 5' high scour.

		deposit restrict flow through span 2. (80 CY)							
Streambed movements	Channel has migrated towards the near abutment; large sediment deposit restrict flow through span 2. (80 CY)	Channel has migrated towards the near abutment; large sediment deposit restricts flow through span 2. (80 CY)	Channel has migrated towards NAB. Alignment of flow impacts WNR. There is a 2 CY eroded area at the free end of the WNR.	Channel has migrated towards NAB. Alignment of flow impacts WNR. There is a 2 CY eroded area at the free end of the WNR	See Section 4.5 above	See Section 4.5.2 above	See Section 4.5.2 above	Channel has migrated towards NAB. Alignment of flow impacts WNR. There is a 2 CY eroded area at the free end of the WNR.	
Debris. Vegetation	Moderate accumulations of miscellaneous and timber debris in channel. (1 CY)	Moderate accumulations of miscellaneous and timber debris in channel. (1 CY)	None.	Sediment deposit and debris block opening to Span 2 at upstream end; Timber debris (3 CY) is wedged against the upstream nose of pier.	See Section 4.5 above	See Section 4.5.2 above	See Section 4.5.2 above	Minor timber debris at upstream nose (1 CY).	
Drift Other	Alignment flow impacts near right wingwall.	Alignment flow impacts near right wingwall.	Large sediment deposit (50 CY) under span 2 along P1 far face and FAB with branches, leaves and sediment accumulating on channel bottom.	Large sediment deposit (50 CY) under Span 2 along P1 far face and FAB with branches, leaves and sediment accumulating on channel bottom.	See Section 4.5 above	See Section 4.5.2 above	See Section 4.5.2 above	Large sediment deposit (30 CY) below the waterline in Span 2 along P1 far face and FAB with branches, leaves and sediment accumulating on channel bottom. Long term sediment deposit with vegetation at upstream end of span 2.	

## 4.6 REVISED DESIGN GUIDELINES OF PGR AT BRIDGE PIERS AND ABUTMENTS

The design guidelines provide the technical approach, applicable standards and specifications for utilizing PGR as a scour countermeasure for bridges in the State of Pennsylvania. Based on the learned experience of designing and constructing PGR scour countermeasure at Bridge SR2028 in-the-dry, the design guidelines of Section 3.1 were revised. The revised design guidelines include a description of PGR, materials, design standards, water quality management, measurement and payment, and construction specifications for in-the-dry PGR.

### 4.6.1 DESCRIPTION

This work consisted of constructing PGR countermeasures around bridge piers and abutments in-the-dry conditions in accordance with PennDOT Standard Specification Publication 408.

PGR construction involves furnishing and placing rock riprap at designated locations shown in the contract drawings and specifications, and project special provisions. The riprap is placed on top of a filter layer consisting of a geotextile fabric and a granular material. The voids of the riprap are then partially filled with a Portland cement-based grout by hose or tremie placement technique. The final configuration results in a partially grouted layer that retains approximately one-half to two-thirds of the void space of the original placement configuration

#### 4.6.1.1 MATERIALS

##### 4.6.1.1.1 ROCKS

The Contractor shall furnish only rocks that meet the requirements of Class Size No R-5, R-6, and R-7 of Section 850.2 (a) 1 and 850.2 (a) 2.

##### 4.6.1.1.2 GEOTEXTILE

The Contractor shall furnish only Geotextile – Class 4, type A as specified in Section 735.1 (b) and confirm to the requirements of Section 735.1

##### 4.6.1.1.3 GRANULAR FILTER

The Contractor shall furnish only coarse aggregate AASHTO Number 57 Type A as specified in Section 703.2.

##### 4.6.1.1.4 GROUT

The Contractor shall furnish Portland cement base concrete with grout mix design that meets the requirements of Section 1.4.1 “Grout Mix.” Use the following materials:

- a. Cement – Type I or Type II, Section 701
- b. Fine Aggregate – Type A, Section 703.1
- c. Coarse Aggregate – AASHTO Number 8, Section 703.2
- d. Water – Section 720.1
- e. Air Entraining Admixture –Section 711.3(d)
- f. Water-Reducing Admixture – Section 711.3(f)

*Grout Mix*

The contractor will be required to submit grout mix results from a certified material testing laboratory for review and approval. The grout mix must comply with design parameters in Table 13 and the material testing requirements of this section. Construction shall not commence prior to the approval of grout mix.

<b>Table 13: Target Grout Mix Design</b>	
Material	Quantity by weight for one cubic yard of grout, pounds
Portland cement, Type I or Type II	740 to 760
Fine Aggregate, dry	1,180 to 1,200
¼" crusher chips or AASHTO No. 8 (coarse aggregate), dry	1,180 to 1,200
Water-Cement Ratio (w/c)	0.40 to 0.45
Air entrained Admixture	Manufacturer Recommendation
Water-Reducing Admixture	Manufacturer Recommendation

- The targeted grout mix should result in a wet grout density ranging from 120 to 140 lb/ft<sup>3</sup>. Wet densities outside this range shall be rejected and the mix re-evaluated for material properties of the individual constituents.
- The targeted grout mix shall result a minimum air content of 6% in the plastic state.

- Spread Test – Using ASTM C 1611 “Standard Test Method for Slump of Self-Consolidating Concrete” Procedure B, referenced as “Spread-Test” is used to evaluate grout quality and consistency. The target values for the Spread-Test measurements are presented in the Table 14.

<b>Table 14: Grout Diameter During Spread Test</b>	
For placement in-the-dry	15.0 to 18.0 inch

*Field Quality Assurance Requirements*

Conduct a consistency test on the grout mix using ASTM C 1611 “Standard Test Method for Slump of Self-Consolidating Concrete” Procedure B, referenced as “Spread-Test”. The “Spread-Test” shall be performed a minimum of two times per batch. The consistency test shall be completed once at the beginning of the grout mix and once at approximately halfway of the grouting operations.

*Consistency “Spread-Test” Requirements*

The grout shall be delivered to the site without admixtures and with 10% less water than indicated in the approved grout mix design. The final grout consistency shall be developed via a trial and error procedure according to the following steps:

- Perform an initial “spread-Test” as specified in ASTM C 1611, Procedure B. Record the average measurement in the orthogonal direction and compare with the grout mix requirement of Table 6 above. The Engineer shall verify that the grout mix complies with the required parameters.
- Add additional water if indicated, remix for five minutes, and retest.
- If the tested grout does not meet the spread limit requirements of Table 6, add more water, remix for an additional five minutes, and retest.
- The Engineer shall not approve the grout mix if the total elapsed time since the initial batching exceeds 100 minutes.
- Grout that meets the spread test and elapsed time requirements shall be considered approved and can be used for partially grouting the riprap

**4.6.1.1.5 COMBINED GEOTEXTILE AND GRANULAR FILTER**

Use 6-inch layer of AASHTO Number 57 Type A coarse aggregate that meet the requirements of Section 703.2 on top of Geotextiles - Class 4, Type A non-woven geotextiles, as specified in Sections 735, 212.2 and 212.3(d).

## 4.6.2 DESIGN STANDARDS

### 4.6.2.1 LAYOUT DIMENSIONS

#### 4.6.2.1.1 PIERS

The PGR shall be installed to the limits and details indicated on the design plans. Sample plans showing PGR layout/dimensions and details for protecting existing piers are presented in Figure 13. In general, the final elevation of PGR countermeasure at the upstream and downstream placement limits shall be flush/blended with the natural riverbed material.

#### 4.6.2.1.2 ABUTMENTS

The PGR shall be installed to the limits and details indicated on the design plans. Sample plans showing PGR layout/dimensions and details for protecting existing abutments are presented in Figure 14. In general, the final elevation of PGR countermeasure at the upstream and downstream placement limits shall be flush/blended with the natural riverbed material.

## 4.6.3 CONSTRUCTION IN-THE-DRY SPECIFICATION

### 4.6.3.1 GENERAL

PGR should be installed in a pre-excavated area such that the top surface elevation of the final installation is level with the natural geometry of the surrounding streambed. The original excavated material shall be used to maintain the streambed grade and shall be blended to meet the natural bed materials at the upstream and downstream placement limits. Excavation limits are defined on the design plans and described in Section 4.6.3.3.

The edges of the PGR installation shall be toed into the streambed (deeper) as shown on the design plans and blended to match/meet the existing streambed. Grouting along the immediate interface of the piers or abutments shall be in accordance with the design plans.

Handling and transportation of filter and riprap materials shall minimize segregation of the materials and shall be in accordance with PennDOT standards.

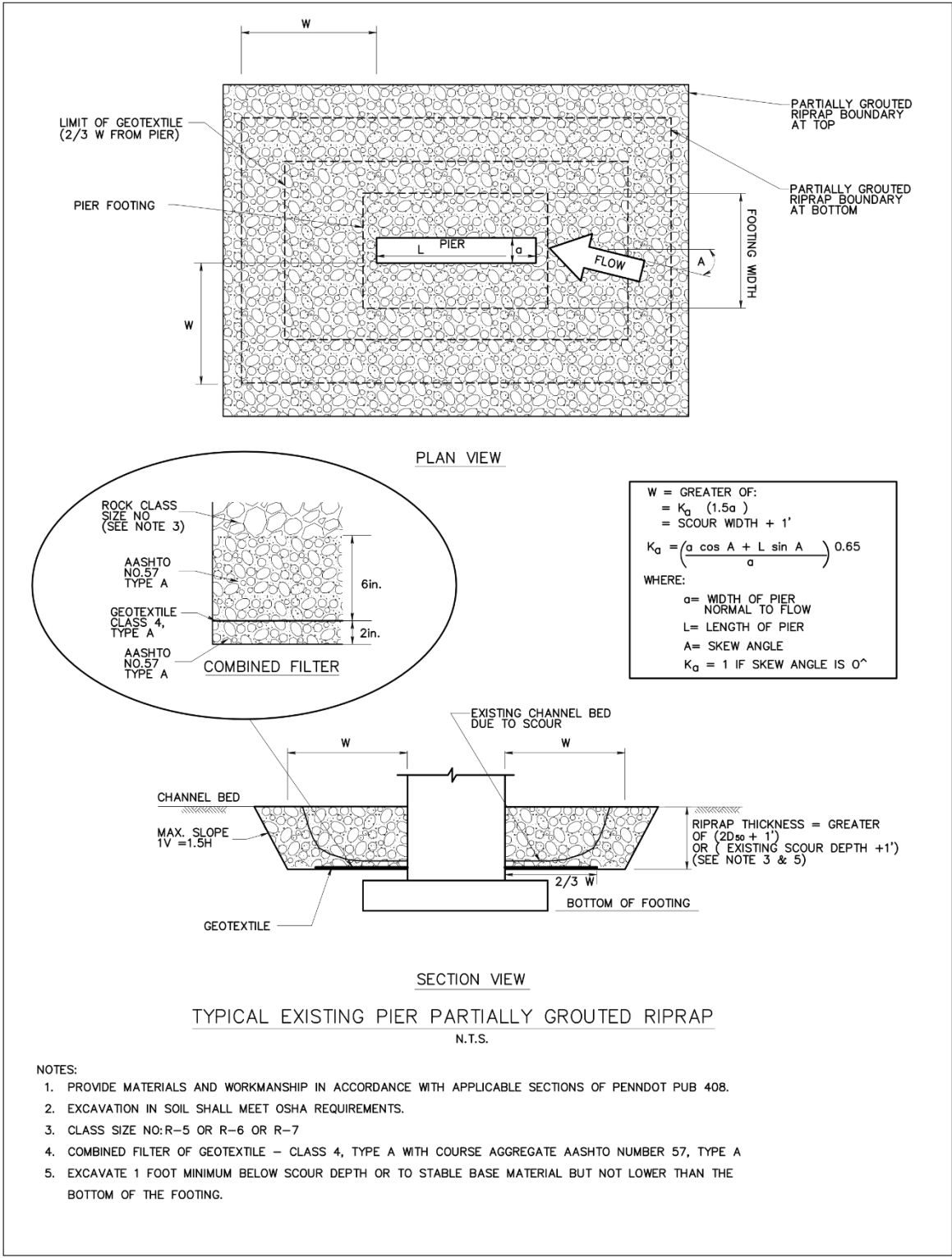

**Figure 13 Existing Pier Layout Dimensions**

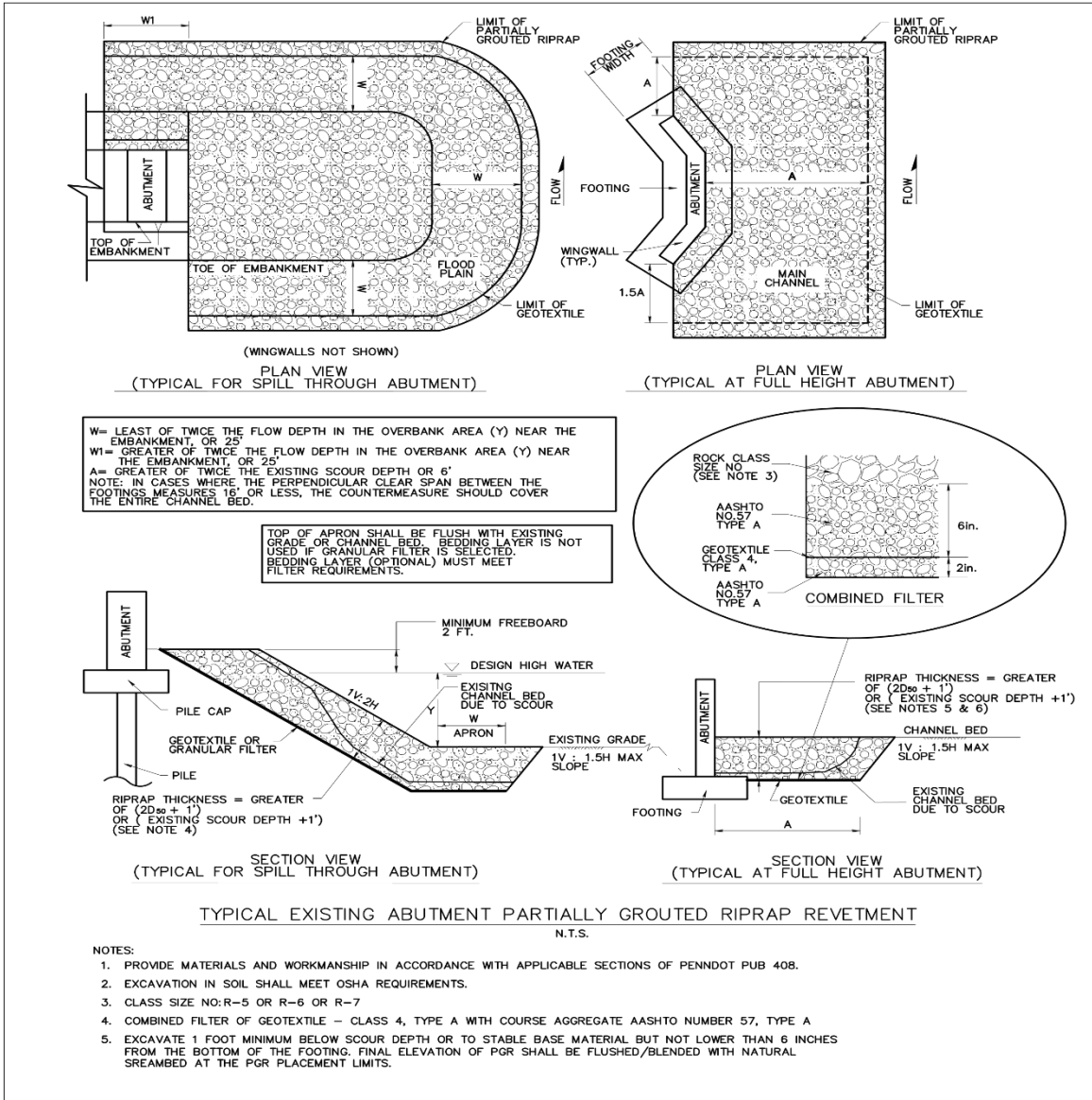

Figure 14 Existing Abutment Layout Dimensions

Following acceptance of the grouting procedure, the area along the perimeter toe of the installation shall be backfilled with native streambed material from the initial excavation.

A phased approach may be recommended at a site to minimize costs and reduce impacts on stream flow management. Additional details will be included in the design plans as needed.

#### 4.6.3.2 CONTRACTOR REQUIREMENTS

The Contractor shall comply with the following:

- Strict adherence to environmental protection and permit restrictions.
- Careful attention to the strict requirements of the grout mix design that includes several admixtures, and potential refinement in the field prior to grout acceptance and placement.
- The Contractor shall comply with Section 4.6.1.1.4 Grout Mix.
- Willingness and ability to work cooperatively with others beyond the normal construction inspector expectations, which may include other representatives of PennDOT, PADEP, USACE, and Engineers.

The Contractor shall conduct a demonstration of the various aspects of this work for observation and ultimate approval by Engineer. The demonstration activities shall include the following, at a minimum:

1. Development of proposed grout mixes (lab results) in accordance with section 4.6.1.1.4
2. Upon approval of the grout mix, the contractor shall conduct a demonstration in accordance with the “PGR Mock-up Training Test Pit Set Up” shown in Figure 13 for observation and the Engineer’s approval.
3. Fill the test pit with riprap to the same thickness as the standard riprap section and grout.

Once approved, the same method/application used in the test pit shall be reproduced for the PGR project installation at the bridge site

#### 4.6.3.3 EXCAVATION

Prior to any streambed excavation, the existing riverbed and bank area geometry shall document existing streambed elevations upstream and downstream of the proposed limits of the PGR installation. Excavation limits shall follow those depicted on the design plans and meet PennDOT standards

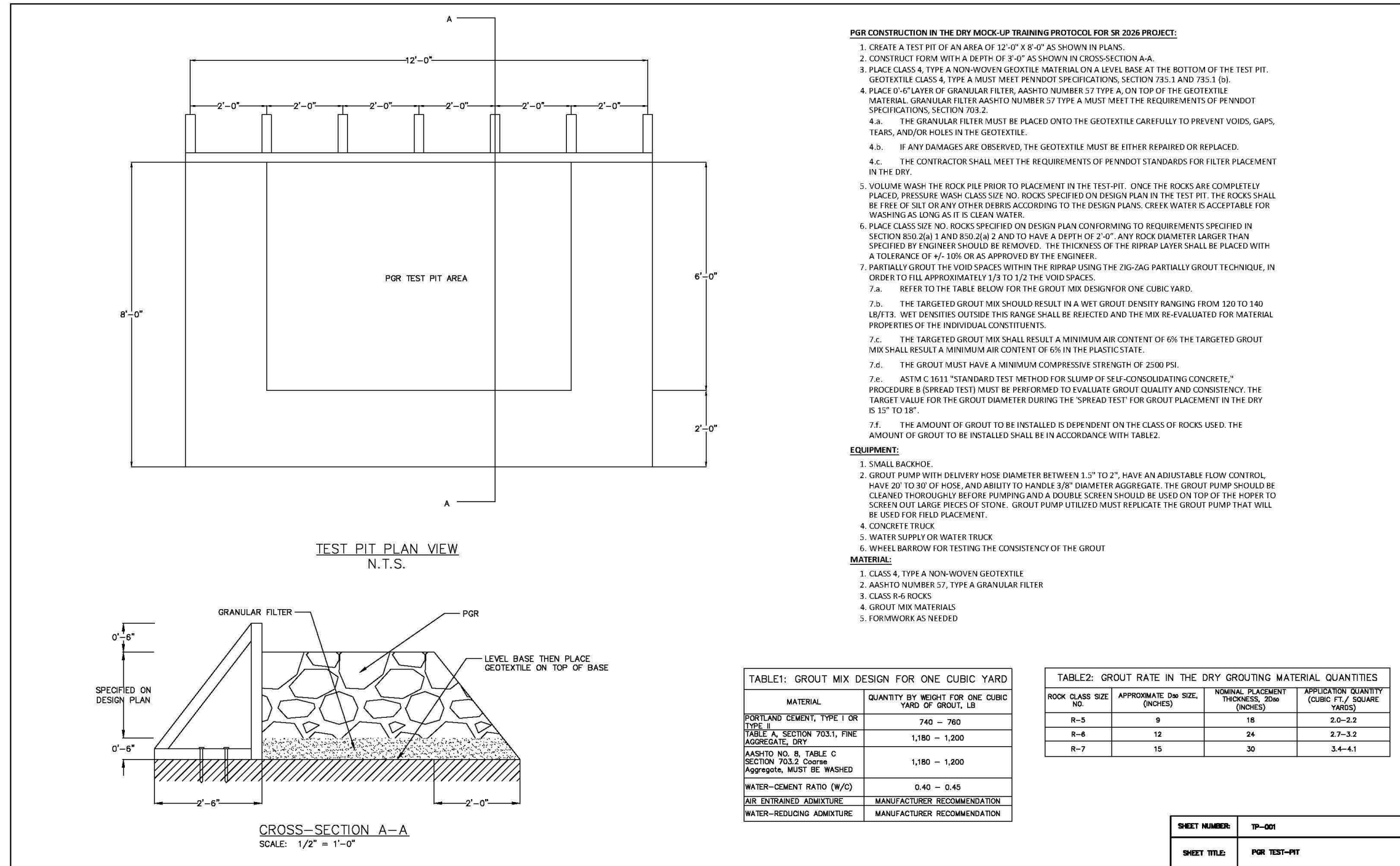

**PGR CONSTRUCTION IN THE DRY MOCK-UP TRAINING PROTOCOL FOR SR 2026 PROJECT:**

1. CREATE A TEST PIT OF AN AREA OF 12'-0" X 8'-0" AS SHOWN IN PLANS.
2. CONSTRUCT FORM WITH A DEPTH OF 3'-0" AS SHOWN IN CROSS-SECTION A-A.
3. PLACE CLASS 4, TYPE A NON-WOVEN GEOTEXTILE MATERIAL ON A LEVEL BASE AT THE BOTTOM OF THE TEST PIT. GEOTEXTILE CLASS 4, TYPE A MUST MEET PENNDOT SPECIFICATIONS, SECTION 735.1 AND 735.1 (b).
4. PLACE 0'-6" LAYER OF GRANULAR FILTER, AASHTO NUMBER 57 TYPE A, ON TOP OF THE GEOTEXTILE MATERIAL. GRANULAR FILTER AASHTO NUMBER 57 TYPE A MUST MEET THE REQUIREMENTS OF PENNDOT SPECIFICATIONS, SECTION 703.2.
  - 4.a. THE GRANULAR FILTER MUST BE PLACED ONTO THE GEOTEXTILE CAREFULLY TO PREVENT VOIDS, GAPS, TEARS, AND/OR HOLES IN THE GEOTEXTILE.
  - 4.b. IF ANY DAMAGES ARE OBSERVED, THE GEOTEXTILE MUST BE EITHER REPAIRED OR REPLACED.
  - 4.c. THE CONTRACTOR SHALL MEET THE REQUIREMENTS OF PENNDOT STANDARDS FOR FILTER PLACEMENT IN THE DRY.
5. VOLUME WASH THE ROCK PILE PRIOR TO PLACEMENT IN THE TEST-PIT. ONCE THE ROCKS ARE COMPLETELY PLACED, PRESSURE WASH CLASS SIZE NO. ROCKS SPECIFIED ON DESIGN PLAN IN THE TEST PIT. THE ROCKS SHALL BE FREE OF SILT OR ANY OTHER DEBRIS ACCORDING TO THE DESIGN PLANS. CREEK WATER IS ACCEPTABLE FOR WASHING AS LONG AS IT IS CLEAN WATER.
6. PLACE CLASS SIZE NO. ROCKS SPECIFIED ON DESIGN PLAN CONFORMING TO REQUIREMENTS SPECIFIED IN SECTION 850.2(a) 1 AND 850.2(a) 2 AND TO HAVE A DEPTH OF 2'-0". ANY ROCK DIAMETER LARGER THAN SPECIFIED BY ENGINEER SHOULD BE REMOVED. THE THICKNESS OF THE RIPRAP LAYER SHALL BE PLACED WITH A TOLERANCE OF +/- 10% OR AS APPROVED BY THE ENGINEER.
7. PARTIALLY GROUT THE VOID SPACES WITHIN THE RIPRAP USING THE ZIG-ZAG PARTIALLY GROUT TECHNIQUE, IN ORDER TO FILL APPROXIMATELY 1/3 TO 1/2 THE VOID SPACES.
  - 7.a. REFER TO THE TABLE BELOW FOR THE GROUT MIX DESIGN FOR ONE CUBIC YARD.
  - 7.b. THE TARGETED GROUT MIX SHOULD RESULT IN A WET GROUT DENSITY RANGING FROM 120 TO 140 LB/FT<sup>3</sup>. WET DENSITIES OUTSIDE THIS RANGE SHALL BE REJECTED AND THE MIX RE-EVALUATED FOR MATERIAL PROPERTIES OF THE INDIVIDUAL CONSTITUENTS.
  - 7.c. THE TARGETED GROUT MIX SHALL RESULT A MINIMUM AIR CONTENT OF 6% THE TARGETED GROUT MIX SHALL RESULT A MINIMUM AIR CONTENT OF 6% IN THE PLASTIC STATE.
  - 7.d. THE GROUT MUST HAVE A MINIMUM COMPRESSIVE STRENGTH OF 2500 PSI.
  - 7.e. ASTM C 1611 "STANDARD TEST METHOD FOR SLUMP OF SELF-CONSOLIDATING CONCRETE," PROCEDURE B (SPREAD TEST) MUST BE PERFORMED TO EVALUATE GROUT QUALITY AND CONSISTENCY. THE TARGET VALUE FOR THE GROUT DIAMETER DURING THE 'SPREAD TEST' FOR GROUT PLACEMENT IN THE DRY IS 15" TO 18".
  - 7.f. THE AMOUNT OF GROUT TO BE INSTALLED IS DEPENDENT ON THE CLASS OF ROCKS USED. THE AMOUNT OF GROUT TO BE INSTALLED SHALL BE IN ACCORDANCE WITH TABLE 2.

**EQUIPMENT:**

1. SMALL BACKHOE.
2. GROUT PUMP WITH DELIVERY HOSE DIAMETER BETWEEN 1.5" TO 2", HAVE AN ADJUSTABLE FLOW CONTROL, HAVE 20' TO 30' OF HOSE, AND ABILITY TO HANDLE 3/8" DIAMETER AGGREGATE. THE GROUT PUMP SHOULD BE CLEANED THOROUGHLY BEFORE PUMPING AND A DOUBLE SCREEN SHOULD BE USED ON TOP OF THE HOPPER TO SCREEN OUT LARGE PIECES OF STONE. GROUT PUMP UTILIZED MUST REPLICATE THE GROUT PUMP THAT WILL BE USED FOR FIELD PLACEMENT.
4. CONCRETE TRUCK
5. WATER SUPPLY OR WATER TRUCK
6. WHEEL BARROW FOR TESTING THE CONSISTENCY OF THE GROUT

**MATERIAL:**

1. CLASS 4, TYPE A NON-WOVEN GEOTEXTILE
2. AASHTO NUMBER 57, TYPE A GRANULAR FILTER
3. CLASS R-6 ROCKS
4. GROUT MIX MATERIALS
5. FORMWORK AS NEEDED

TABLE 1: GROUT MIX DESIGN FOR ONE CUBIC YARD	
MATERIAL	QUANTITY BY WEIGHT FOR ONE CUBIC YARD OF GROUT, LB
PORTLAND CEMENT, TYPE I OR TYPE II	740 - 760
TABLE A, SECTION 703.1, FINE AGGREGATE, DRY	1,180 - 1,200
AASHTO NO. 8, TABLE C SECTION 703.2 Coarse Aggregate, MUST BE WASHED	1,180 - 1,200
WATER-CEMENT RATIO (W/C)	0.40 - 0.45
AIR ENTRAINED ADMIXTURE	MANUFACTURER RECOMMENDATION
WATER-REDUCING ADMIXTURE	MANUFACTURER RECOMMENDATION

TABLE 2: GROUT RATE IN THE DRY GROUTING MATERIAL QUANTITIES			
ROCK CLASS SIZE NO.	APPROXIMATE D <sub>50</sub> SIZE, (INCHES)	NOMINAL PLACEMENT THICKNESS, 2D <sub>50</sub> (INCHES)	APPLICATION QUANTITY (CUBIC FT./ SQUARE YARDS)
R-5	9	18	2.0-2.2
R-6	12	24	2.7-3.2
R-7	15	30	3.4-4.1

SHEET NUMBER:	TP-001
SHEET TITLE:	PGR TEST-PIT

Figure 15 PGR Mock-Up Training Test-Pit

The Contractor shall perform all work in a dewatered and dry environment. The Contractor shall prepare the area required for the full cross section of PGR as indicated in the design plans while providing a low flow channel. This preparation may include, but is not limited to, excavating, removing unsuitable material, backfilling, clearing and grubbing as specified in Section 201.3. Stockpile excavated streambed material to backfill the PGR installation

#### 4.6.3.4 COMBINED FILTER PLACEMENT

The Contractor shall place an approximate 2-inch layer of AASHTO Number 57 Type coarse aggregate, as specified in Section 703.2, on top of the subgrade to level subgrade base. On top of the approximate 2-inch layer of AASHTO Number 57 Type coarse aggregate, the Contractor shall place geotextile Class 4, Type A non-woven geotextiles, as specified in Sections 735, 212.2 and 212.3(d). Contractor will then carefully place 6-inch of No. 57 Coarse Aggregate, Type A, on the geotextile to avoid voids, gaps, tears or holes in the geotextiles as shown on the design plans. If any damages are observed, the geotextile must be repaired or replaced.

#### 4.6.3.5 RIPRAP PLACEMENT

Riprap shall be placed to the depth indicated on the design plans. The thickness of the riprap layer shall be placed with a tolerance of +/- 10% or as approved by the Engineer. Place the rock in 18-in minimum lifts to prevent segregation and to avoid displacement of the underlying material. Do not place rock by dumping into chutes or by similar methods likely to cause segregation or geotextile damage. Rearrange individual rocks, if necessary, to ensure uniform distribution. Riprap shall be free of silt or any other debris. If during the installation of rocks, the de-watered area becomes flooded, wash the rock to remove sediments and fines before commencement of grouting. At the upstream and downstream limits of the riprap shown on the contract drawings, for the final one foot of length, provide an additional one foot of depth of riprap to toe into the streambed and tie into the existing streambed elevations in accordance with the "Upstream/Downstream PGR Toe" detail shown on the design plan.

#### 4.6.3.6 GROUT

The riprap shall be free of silt or any other debris in accordance with the design plans. Prior to grouting, power wash the riprap to remove silt and fines. The amount of grout to be installed shall be in accordance with the Table 15 below, dependent on the rock class size number. The grout pump shall have an adjustable flow control, delivery hose diameter between 1 ½ inch to 2 inches, and the ability to handle 3/8-inch diameter aggregate. Partially grout the void spaces within the riprap using the zig-zag grouting technique to fill approximately 1/3 to 1/2 the void spaces. The target distribution of grout within the riprap matrix shall be such that about 2/3 of the grout should reside in the upper half of the riprap layer, with 1/3 of the grout penetrating the lower half. The grout shall not segregate when being applied to the riprap. The grout must not be allowed to pool on the surface of the riprap, nor puddle onto the filter at the base of the riprap.

Grout along the immediate interface between the riprap and piers/abutments should be in accordance with the design plans. Allow open voids at the surface to maintain permeability in the PGR matrix. Closely monitor the construction methods to ensure surface openings are present and voids are distributed throughout the entire rock matrix. Allow the grout to cure (24) twenty-four hours before permitting any activities on the PGR matrix. The stockpile of natural streambed material shall be placed to the depth indicated on the design plans. The top surface elevation for the final riprap installation shall be consistent with the natural geometry of the surrounding streambed and with the documented existing streambed elevations.

<b>Table 15: Grouting Rate in-the-Dry Grouting Material Quantities</b>			
Rock Class Size NO.	Approximate $d_{50}$ size, inches	Nominal placement thickness, $2d_{50}$ , inches	Application Quantity (cubic ft / square yards)
R-5	9	18	2.0 – 2.2
R-6	12	24	2.7 – 3.2
R-7	15	30	3.4 – 4.1

#### 4.6.3.7 DEWATERING

When the construction can be performed with limited water diversion methods, as approved by the Engineer, the installation of PGR shall proceed in-the-dry as defined on the design plans.

#### 4.6.3.8 SEDIMENTATION AND EROSION CONTROL SYSTEM

A comprehensive Erosion and Sediment Pollution Control Plan (E&SPCP), in accordance with PennDOT standards and following the Pennsylvania Code Title 25 Environmental Protection Chapter 102 "Erosion and Sediment Control, is provided with the design plans for the project.

#### 4.6.3.9 WATER QUALITY MANAGEMENT

The Contractor shall meet the requirements of PennDOT standards for water quality management when construction is in the dry and any conditions included in the permit requirements.

#### 4.6.4 MEASUREMENT AND PAYMENT

##### 4.6.4.1 MEASUREMENT

The measurement for payment of PGR will be the total number of cubic yards of PGR installed.

Excavation and filter material are not included in the bid item for PGR and will be measured separately under their respective items.

Water containment areas, dewatering measures, energy dissipation system, silt fence, water treatment basins, cleanup of the materials associated with providing the water containment area for sediment removal, and water pre-treatment prior to release back into the stream shall be measured separately.

##### 4.6.4.2 BASIS OF PAYMENT

The bid price shall include all costs for supplying, transporting, stockpiling, mixing, and placing all riprap and grout, along with all other related and necessary materials, work, equipment, and testing in accordance with the drawings and specifications.

The demonstration of the Contractor's experience with PGR installation shall not be paid for separately but shall be considered incidental to the work.

Excavated material will be paid for separately under Item 204, Class 2. Waste material shall be disposed of in accordance with Section 105.14 of Publication 408.

Geotextile filter material shall be paid for under Item 212.

Granular filter material shall be paid for under Item 350.

All costs associated with providing the water containment area for sediment removal and treatment prior to release back into the stream shall be paid for separately under Item 855.4 (Pumped Water Filter Bag).

## CHAPTER 5: CONCLUSIONS & RECOMMENDATIONS

---

### 5.1 SUMMARY

Partially grouted riprap (PGR) is relatively new in the United States but has been used widely in Europe to prevent scour or erosion of the bed, banks, shoreline, and at piers and abutments. When PGR is properly designed and constructed, it increases the hydraulic stability of the interlocked riprap units without sacrificing flexibility or permeability and allows for the use of smaller sized rock and thinner riprap layer to create larger conglomerate size riprap. The utilization of smaller sized rocks eliminates the cost and constructability challenges of larger rock sizes in controlling scour.

Environmental impacts are also minimized through the ability of PGR to self-articulate and to permeate biologic and alluvial material into the conglomerate rock formation. Currently in Pennsylvania, the selection of appropriate countermeasures and the design for bridge foundation protection against scour have in general been limited in their applications to mainly dumped or hand-placed riprap, which can be displaced after major flood event. Hence, there is a critical need to develop guidelines to utilize PGR as a permanent countermeasure to control scour at bridge piers and abutments. The goal of this research project was to develop guidelines for scour countermeasure at piers and abutments using PGR as a permanent countermeasure for scour control and remediation that minimizes environmental impacts and demonstrates strong cost benefit/low life cycle costs.

A comprehensive literature review was conducted at the beginning of the research project and presented in Chapter 2 of his report. The objective of the literature review was to provide a review of the state-of-the-art in the use of PGR as a scour countermeasure for protection of bridge piers and abutments against scour. The review covers the basic concept of scour and the countermeasures used to prevent and repair the damage caused by scour. Findings from the literature review on installation procedures and relevant water quality studies were intended to provide overviews rather than comprehensive descriptions.

HEC 23 Design Guidelines 12 “Partially Grouted Riprap at Bridge Piers” (1, 2) provided general requirements for grouting materials. The grout requirements were based on guidance developed by Federal Waterway Engineering and Research Institute (BAW) in Germany. An experimental research study was established in this research project to develop grout trial design mixes to be used in the scour countermeasure construction of partially grouted riprap in-the-dry and in-the-wet at the selected scour critical bridge in District 6-0. In the experimental research, a number of

grout quality control tests were conducted and a correlation between the European Flow Table Test and ASTM C 1611 “Standard Test Method for Slump of Self-Consolidating Concrete” Procedure B, referenced as “Spread-Test” was established. The experimental test results are presented in Appendix B. Recommendations for grout mix design for construction in-the-wet and in-the-dry were developed with general guidance of grouting materials for the design guidelines of PGR for piers and abutment.

Since PGR is not velocity dependent, there are no basic relationships for selecting the size of rock, other than the practical considerations of proper void size, gradation stone-to-stone contact area. The intent of partial grouting is to interlock the smaller riprap stones together to create “conglomerate particles” that resist higher flow velocities. Each conglomerate particle is therefore significantly larger than the  $d_{50}$  size of the individual stones, and typically is larger than the  $d_{100}$  size of the individual stones in the riprap matrix. Only stones with a  $d_{50}$  ranging from 9 inches to 15 inches should be used with the partial grouting technique (1, 11). The PennDOT Class Size No R5, R6, and R7 are suitable for PGR. PennDOT Class Size less than R5 contains voids that are too small for the grout to effectively penetrate the required depth within the rock matrix. While rocks larger than Class Size No R7 contains voids that are too large to retain the grout, and do not have enough contact area between the stones to effectively interlock them together. Selecting Class Size, No R5 or R6 or R7 should be determined based on the economics of locally available material.

A host of scour countermeasures matrix have been developed specifically for Pennsylvania bridges to address a specific type(s) of scour and to provide methodology/procedures/standard design drawing for selecting and designing functional and cost-effective scour countermeasures (2). The standard drawings provide a simplification and standardization of the scour countermeasure layout/dimensions and details. Figure 13 and 14 provide the standard design/layout/dimension/and details for PGR of existing piers and abutments. For new construction of PGR at piers and abutment refer to reference 2.

Taking into consideration HEC-23 “Design Guideline 12”(1), draft design guidelines of PGR at bridge piers and abutments was developed in collaboration and advisement on the technical direction of the research project by the Technical Advisor of PennDOT District 6-0 and the Technical Panel (regulatory agencies) of DEP and COE. The design guidelines provided the technical approach, applicable standards, and specifications for utilizing PGR as a scour countermeasure for bridges in PennDOT District 6-0 and the State of Pennsylvania. The draft design guidelines included a description of PGR, materials, design standards, construction specifications in-the-dry and in-the-wet, water quality management, and measurement and payment. With the assistance of PennDOT District 6-0 Technical Advisor, an existing scour critical bridge SR 2028 was selected to have PGR as a scour countermeasure to protect the structure from scour. The bridge has a scour critical designation and was originally constructed in 1931. Based on the draft design guidelines Plans, Specs, & Estimate (PS&E) package was developed under general permit BWEW-GP-11 – Maintenance. The PS&E package included:

- layout dimensions for PGR at piers and abutments for construction in-the-dry and in-the-wet
- riprap size and mechanical and physical properties of riprap.
- grout requirements for construction in-the-wet and in-the-dry.
- filter requirements.
- construction plans.
- construction specification.
- engineering calculations and estimates.
- recommendation for PE&S plan.
- recommendation for environmental monitoring before, during, and after construction.
- recommendations for environmental testing.

A pre-application meeting was held with the DEP and COE to review/discuss in detail each phase of PGR construction in-the-dry and in-the-wet at bridge SR 2028 and to determine the level of permitting required for the project. At the conclusion of the meeting, both regulatory agencies indicated a General Permit BWEW-GP-11 would not be applicable and required the highest level of permitting, Individual Permits (IP), as both agencies determined that construction of PGR in-the-wet would likely cause more than minimal adverse impacts to aquatic life. The COE also specifically required a 404(b)(1) Guideline Analysis, which includes rigorous purpose, need, and alternative analysis. Due to extensive permit requirements necessary for an IP application a Permitting Team was established. The goal of the Permitting Team was to modify or revise the project proposal in order to convince the DEP/COE to reduce the permit requirements from an IP to a GP-11. If the DEP/COE insisted on IP after project proposal revisions, the Permitting Team would evaluate the likelihood of the IP being approved by the state and federal regulatory agencies. The Permitting Team made every effort to modify the scope of the project to meet agency concerns regarding water quality during the construction in-the-wet and has concluded that the applicant will have significantly less than 50% chance of obtaining a permit with the current approach. Due to the substantial effort required to complete a draft of the required permit (significant Environmental Assessment, Pre and Post biological studies) it is recommended that it would be beneficial to conduct further complimentary research on developing a strong purpose and need statement for PGR construction in-the-wet. The purpose and need statement would need to thoroughly explain why construction of PGR in-the-wet is not only far superior to construction of PGR in-the-dry, but also outline the reasons why installing PGR in-the-wet has less of an environmental impact than installing PGR in-the-dry.

Given the above information, the Temple research team and PennDOT District 6-0 Technical Advisors decided to change the application of PGR construction in-the-wet and in-the-dry to the selected scour critical bridge SR 2028 to only be installed in-the-dry, which allowed the permit to be reviewed as a GP-11. Based on the draft design guidelines developed in Section 3.1 for PGR construction in-the-wet and in-the-dry, the PS&E package and the General Permit BWEW-GP-11 for the construction of PGR in-the-dry at PennDOT District 6-0 scour critical bridge SR 2028 was prepared by Designer and approved by the designated agencies. Under Force Account Agreement

an experienced contractor was selected to construct the PGR in-the-dry at bridge SR 2028. During site preparation the Contractor accidentally damaged, downstream, a small part of the gas main line that was near the bridge. Due to the close proximity of the gas main line to upstream and downstream near abutment of span 1, and the location of scour holes, the PGR around the end of the near abutment wingwall was eliminated. Further, since the flow was mostly directed to Span 1 due to misalignment of the upstream channel with the bridge opening and constant sediment buildup in Span 2, the District 6-0 Bridge Engineer, on the assumption that Span 2 will always have sediment buildup that would prevent flow of water in Span 2, decided to eliminate PGR in Span 2. As a result, the dimensions of the PGR were reduced to one span. Also, the temporary stream diversion devices were replaced by bypass pumping system. The construction of PGR at bridge SR 2028 started on November 10, 2017 and was completed on December 18, 2017. The PGR was installed in-the-dry in two phases and the water quality was monitored before, during, and after the construction of PGR at bridge SR 2028. Water quality parameters monitored were pH, temperature, and turbidity. The construction of PGR in-the-dry had no impact on water quality.

The as constructed PGR at bridge SR 2028 was assessed twice by the Temple research team. Additionally, as mandated by FHWA, a subcontractor of PennDOT District 6-0 conducted a two-year cycle of NBIS to determine the performance and the needed maintenance of the constructed PGR countermeasure. The constructed PGR countermeasure performed as intended with no dislodging of rock or development of scour holes in Span 1. Based on the learned experience of designing and constructing PGR scour countermeasure at Bridge SR2028 in-the-dry, the design guidelines of Section 3.1 were revised (Section 4.6). The design guidelines of PGR in-the-dry at bridge piers and abutments provides the technical approach, applicable standards, and specifications for utilizing PGR as a scour countermeasure for bridges in the State of Pennsylvania. The revised design guidelines include a description of PGR, materials, design standards, water quality management, measurement and payment, and construction specifications in-the-dry.

## 5.2 CONCLUSIONS

This research project provides the much-needed tools for utilizing PGR as a lasting remedial scour countermeasure for existing scour critical bridges and as permanent scour countermeasure measure for new bridges in PennDOT District 6-0 and in the State of Pennsylvania. The developed design guidelines of PGR at bridge piers and abutment in-the-dry will allow a uniform, practical, effective, and economical approach and design of scour countermeasure for PennDOT districts with scour critical bridges. The research demonstrated that utilizing PGR for PennDOT District 6-0 bridge SR 2028 was the most functional and cost-effective scour countermeasure with minimum environmental impact. Although, PGR was applied in-the-dry for this project, it is important to evaluate construction of PGR in-the-wet as a viable scour countermeasure option and that the draft design guidelines of PGR at bridge piers and abutment in-the-dry and in-the-wet provided

to the DEP and COE meet the regulations set forth by both regulatory agencies. Expectantly, this research should lead to the use of new, state-of-the-art PGR scour countermeasure technology in the state of Pennsylvania.

### 5.3 IMPLEMENTATION & RECOMMENDATIONS

In order to obtain the best possible results from this research project, the information presented in this report must be properly implemented. The developed design guidelines of PGR at bridge piers and abutment in-the-dry provide the technical approach, applicable standards, and specifications for utilizing partially grouted riprap as a scour countermeasure for bridges in PennDOT District 6-0 and the State of Pennsylvania. To implement the developed and proposed methodologies and procedures in this research project, this report should be reviewed and commented on by all the districts in Pennsylvania with the intention for implementation as recommended practice. Additionally, the well-researched, documented, and proven application of PGR in this report should be submitted to the State Transportation Innovation Council (STIC) for broader development and deployment.

Although this research project can be used as a standalone document, it would be beneficial to conduct further, complimentary research on PGR in-the-wet. The research study of PGR in-the-wet should quantify the environmental impacts with the initial impact of construction and maintenance on the water quality and aquatic life. Such research would allow the State of Pennsylvania to expand their knowledge and experience with PGR as a scour countermeasure and create more economical and functional practices throughout the state

## REFERENCES

---

1. Lagasse, P. F., Clopper, J. E. Pagán-Ortiz, L. W. Zevenbergen, L. A. Arneson, J. D. Schall, and L.G. Girard Hydraulic Engineering Circular No.23: Bridge Scour and Stream Instability Countermeasures Experience, Selection, and Design Guidance. 3rd ed. Vol. 1. Washington, D.C: FHWA-NHI-09-11, 2009. Print.
2. Abboud, B.E. and Kaiser, S., "Final Report - Selection & Design of Scour Countermeasures for Pennsylvania Bridges", The Pennsylvania Department of Transportation, Bureau of Planning and Research, Report No. FHWA-PA-2012-001-TEM 001, Final report, August 3, 2012, 1008 pages.
3. Bundesanstalt für Wasserbau (BAW), "Guidelines for Testing of Cement and Bitumen Bonded Materials for Grouting of Armor Stones on Waterways" (RPV), Karlsruhe, Germany, 1991.
4. Bundesanstalt für Wasserbau (BAW). "Code of Practice – Use of Cement Bonded and Bituminous Materials for Grouting of Armor Stones on Waterways" Karlsruhe, Germany, 2008.
5. Clopper, P.E. and Thornton, C.I, "water Quality Aspect of Partially Grouted Riprap", ASCE World Environmental and Water Resources Congress 2008, Honolulu, Hawaii, United States.
6. McCullah, J.A., and D. Gray, "Environmentally Sensitive Channel- and Bank- Protection Measures", NCHRP Report 544, Transportation Research Board, National Academy of Science, Washington, D.C., 2005.
7. Girard, Laura G., and Paul E. Clopper. Integrating European Partially Grouted Riprap for Stream Stability and Bridge Scour Protection. Tech. Print.
8. Lagasse, P.F., Clopper, P.E., and L.A. Arneson, "Partially Grouted Riprap as a Pier Scour Countermeasure," ASCE World Environmental and Water Resources Congress 2008, Honolulu, Hawaii, United States.
9. Barkdoll, B.D., Ettema, R., Melville, B.W, NCHRP Report 587: Countermeasures to Protect bridge Abutments from Scour, Transportation Research Board, National Research Council, Washington, D.C. 2007.
10. Heibaum, M.H, "Scour Countermeasures Using Geosynthetics and Partially Grouted Riprap," Transportation Research Record 1696, Vol. 2, Paper No. 5B0106, pp. 244-250.
11. Lagasse, Peter F., P. E. Clopper, L. W. Zevenberge, and L. G. Girard. NCHRP Report 593: Countermeasures to Protect Bridge Piers from Scour. Washington, D.C.: Transportation Research Board, 2007. Print.

12. Richardson, E.V. and Davis, S.R, "Evaluating Scour at Bridges," Hydraulic Engineering Circular 18, Fourth Edition, FHWA NHI 01-001, Federal Highway Administration, U.S. Department of Transportation, Washington, D.C., 2001.
13. Lagasse, Peter. "1998 Scanning Review of European Practice for Bridge Scour and Stream Instability Countermeasures." Research Results Digest – National Cooperative Highway Research Program, Washington D.C., July 1999.
14. Federal Waterway Engineering and Research Institute (BAW), Code of Practice – Use of Geotextile Filters on Waterways (MAG). BAW, Karlsruhe, Germany.
15. Federal Waterway Engineering and Research Institute (BAW), "Code of Practice – Use of Standard Construction Methods for Bank and Bottom Protection on Waterways (MAR)," BAW, Karlsruhe, Germany, 1993a.
16. Fitch, G.M., Minimizing the Impact on Water Quality of Placing Grout Underwater to repair Bridge Scour Damage," Final Report, VTRC 03-R16, Virginia Transportation research Council, Charlottesville, VA.
17. Danielson-Bartelt, N., "*Matrix Riprap Implementation*. Minnesota Department of Transportation: Oakdale (Minnesota)". 32-1679.00, 2013.
18. Horne, W., "*Holderness Bridge No. 109/109 PGR Scour Repair Summary*," New Hampshire Department of Transportation, Owl Brook (New Hampshire), 2011.
19. United States. Pennsylvania Code. Commonwealth of Pennsylvania. PA Code Title 25: Chapter 93 Water Quality Standards. N.p.: n.p., 2017. Print. 47 Pa.B. 170.
20. United States. Pennsylvania Department of Environmental Protection. Bureau of Waterways Engineering and Wetlands. Erosion and Sediment Pollution Control Program Manual. N.p.: n.p., 2012. Print. 363-2134-008

## APPENDICES

---

## APPENDIX A “ROCK RIPRAP/SIZE”

HEC-23 Design Guidelines 12 (HEC-23 DG-12) (1, 2) provides recommended gradations for standard classes of riprap. These proposed gradation criteria result in a generally well-graded riprap. Only classes II, III and IV shown in Table A-1 are suitable for use in PGR applications.

Nominal Riprap Class by Median Particle Diameter		d <sub>15</sub>		d <sub>50</sub>		d <sub>85</sub>		d <sub>100</sub>
Class	Size	Min	Max	Min	Max	Min	Max	Max
II	9 in	5.5	7.8	8.5	10.5	11.5	14.0	18.0
III	12 in	7.3	10.5	11.5	14.0	15.5	18.5	24.0
IV	15 in	9.2	13.0	14.5	17.5	19.5	23.0	30.0

1. d<sub>15</sub>, d<sub>50</sub>, d<sub>85</sub>, and d<sub>100</sub> refer to the particle size in the distribution curve corresponding to 15, 50, 85 and 100 percent finer, respectively. Since there is a maximum and minimum for each case, with exception to d<sub>100</sub>, a gradation envelope can be plotted for each of the three classes and an acceptable region of particle sizes for each case can be illustrated.

PennDOT uses the R-value system for classification of rocks sizes as shown in Table A-2.

Percent Passing (Square Openings)						
Class, Size No. (NCSA)	R-8	R-7	R-6	R-5	R-4	R-3
Rock Size, millimeters (inches)						
1070 (42)	100*					
760 (30)		100*				
610 (24)	15-20		100*			

460 (18)		15-50		100*		
380 (15)	0-15					
300 (12)		0-15	15-50		100*	
230 (9)				15-50		
150 (6)			0-15		15-50	100*
100 (4)				0-15		
75 (3)					0-15	15-50
50 (2)						0-15
Nominal Placement Thickness, millimeters (inches)	1220 (48)	915 (36)	800 (30)	610 (24)	460 (18)	305 (12)

\* Maximum allowable rock size

The PennDOT Class Size No R-values are different from the HEC-23 DG-12 classes in two noticeable ways. There are only three given rock sizes for each range of percent passing leading to a less well graded class, whereas the HEC-23 DG-12 classes specify four; and the gradation envelope is based on a scope of percent passing rather than particle sizes. Although the presence of gradation envelope will still be present when plotted, the shape of the envelope from these different classifications will be different.

Based upon envelope plotting and comparison shown in Figure A-1, A-2, and A-3, it was found that the Class Size No R-8 and R-7 are comprised of particles too large for PGR, and Class Size No of R-4 and R-3 are comprised of particles too small. As indicated in HEC-23 DG-12, too large or too small particle sizes compromise grout placement in PGR.

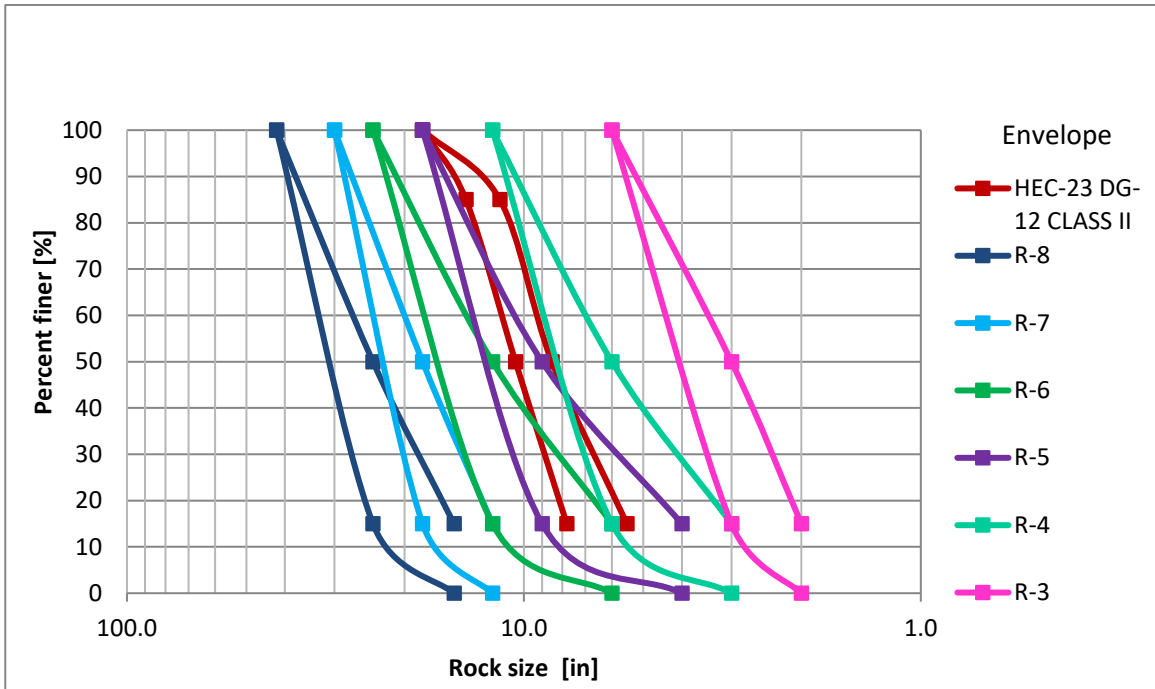

Figure A-1: Comparison of Rock Gradation Envelope Between HEC-23 DG-12 Class II and PennDOT Class Size No R-Values

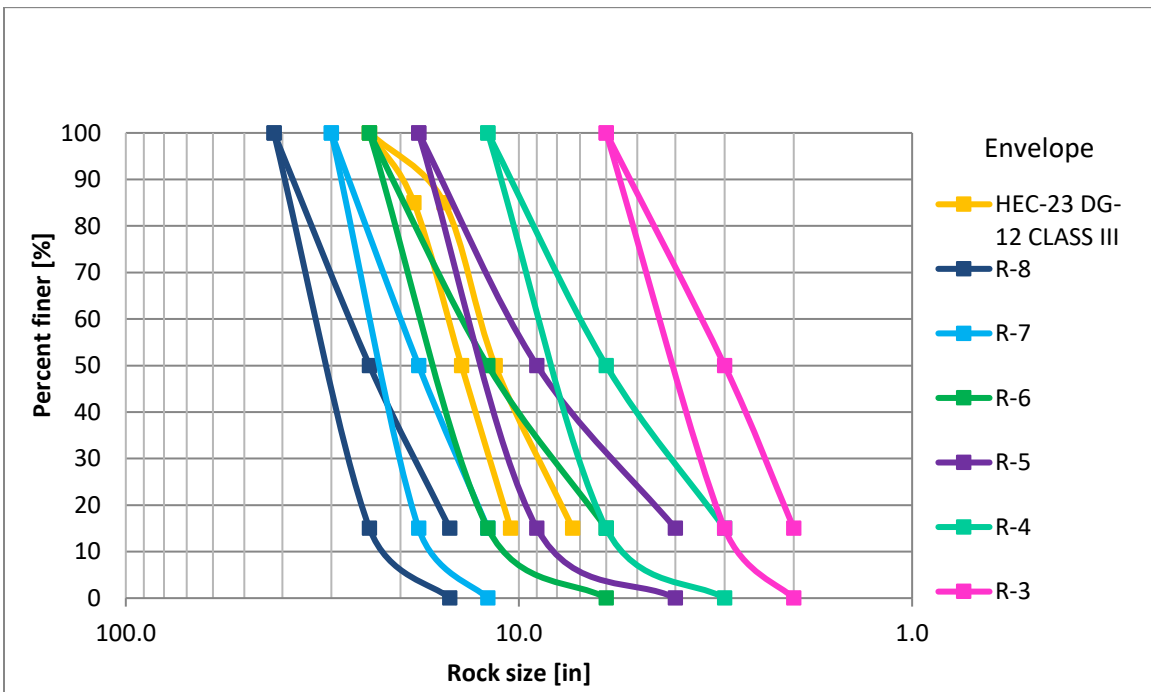

Figure A-2: Comparison of Rock Gradation Envelope Between HEC-23 DG-12 Class III and PennDOT Class Size No R-Values

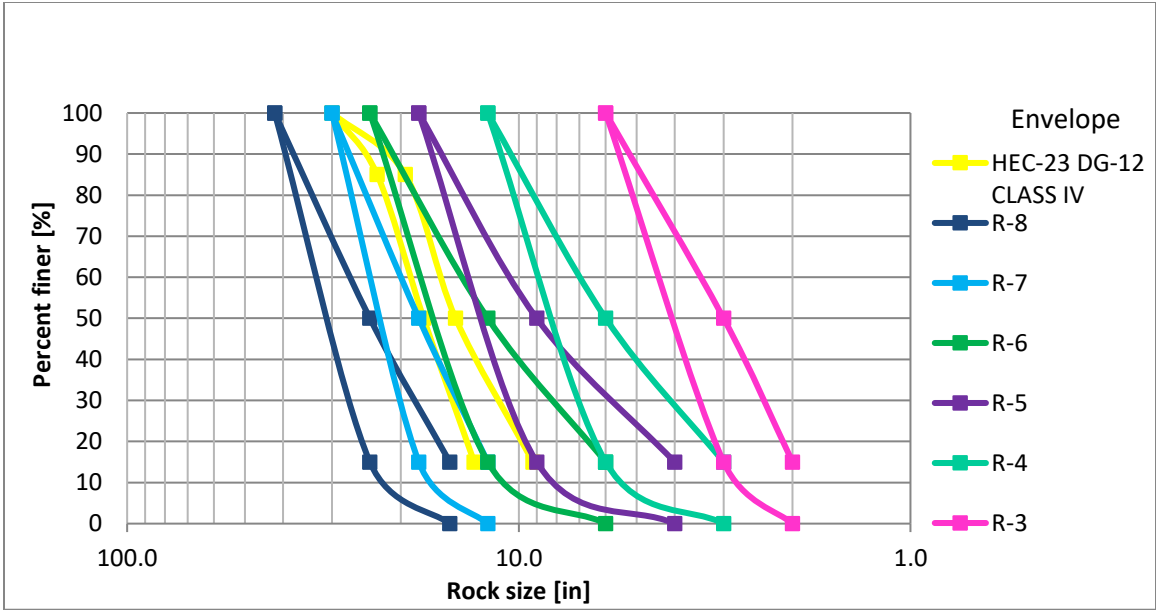

Figure A-3: Comparison of Rock Gradation Envelope Between HEC-23 DG-12 Class IV and PennDOT Class Size No R-Values

Due to the above-mentioned differences in the classification specifications, none of the PennDOT Class Size No R-Values gradation envelopes fell within a single HEC-23 DG-12 class gradation envelope. Since the HEC-23 DG-12 class II, III, and IV are all suitable for partially grouted riprap and not velocity dependent, a new gradation envelope can be formed with the minimum gradation for HEC-23 DG-12 class II as the lower bound, and the maximum gradation for HEC-23 DG-12 class IV as the upper bound. With this new gradation envelope shown in Figure A-4 and A-5, it is shown that R-6 classification envelope resides within the HEC-23 DG-12 recommended limits.

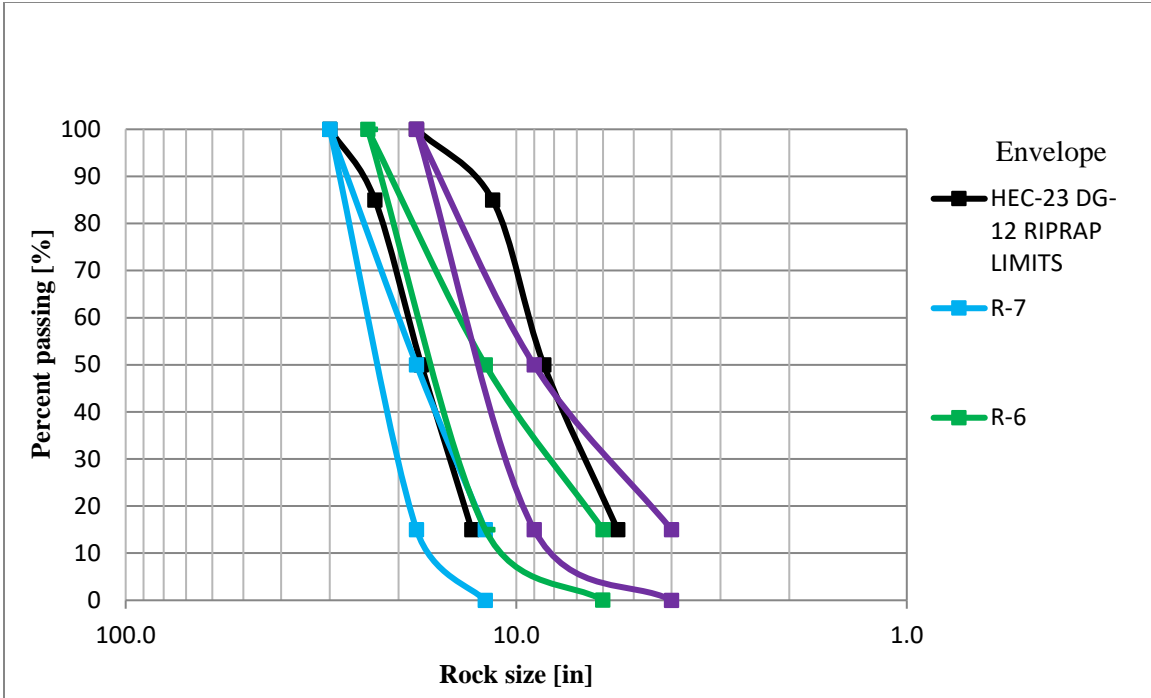

Figure A-4: Gradation Envelope for HEC-23 DG-12 Riprap Class Limits and PennDOT Class Size No R-5, R-6, and R-7

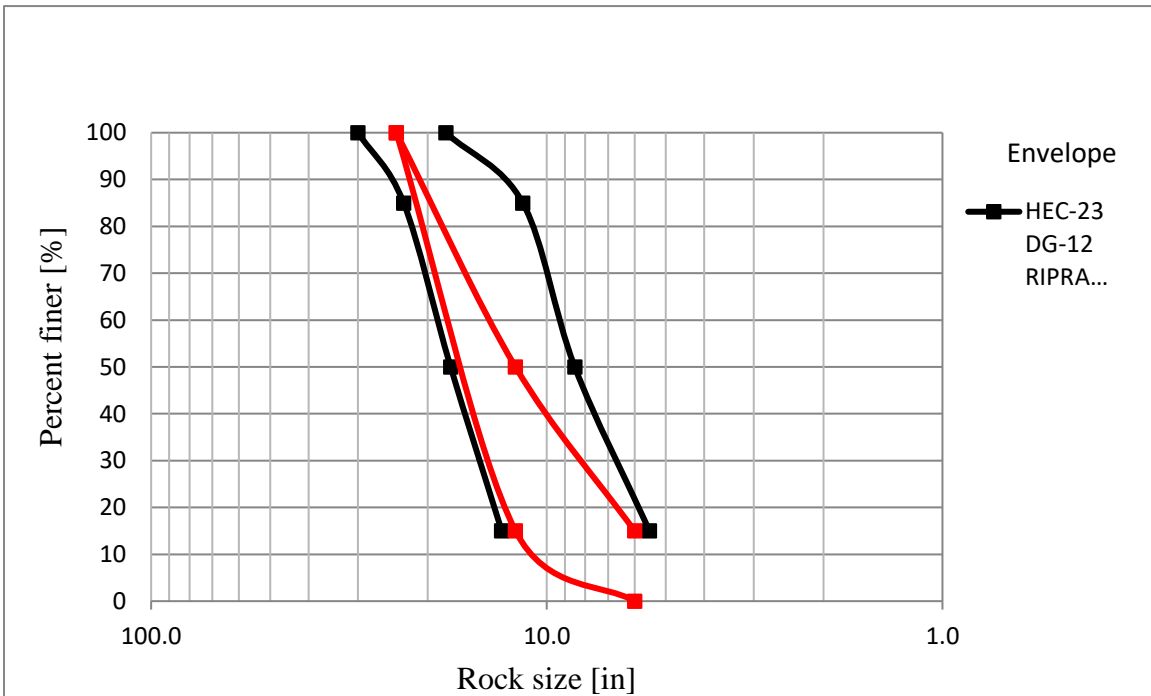

Figure A-5: Gradation Envelope for HEC-23 DG-12 Riprap Class Limits and PennDOT Class Size No R-6

It is therefore recommended that the PennDOT Class Size No R-6 rock classification be used for PGR applications. Although it is not recommended to use R-5 classification, much of the larger graded rock sizes did coincide within the acceptable region recommended by HEC-23 DG-12; however, the R-5 class appears to contain particle sizes too small for PGR applications.

As an alternative to using HEC-23 DG-12 minimum gradation for class II as the lower bound, and the maximum gradation for class IV as the upper bound, a modification to the gradation envelope of the PennDOT Class Size No R-5, R-6, and R-7 was applied to conform to HEC-23 DG-12 class II, III, and IV, respectively. Table A-3 shows the modified Class Size No

Table A-3 Size and Gradation of the Modified Class Size No			
Class, Size No.	Percent Passing (Square Openings)		
	R-7M	R-6M	R-5M
Rock Size, millimeters (inches)			
1070 (42)			
760 (30)	100*		
610 (24)		100*	
460 (18)	65-85		100*
380 (15)	35-55	65-85	
300 (12)	5-15	35-55	65-85
230 (9)			35-55
150 (6)		5-15	5-15
100 (4)			
75 (3)			
50 (2)			
Nominal Placement Thickness, millimeters (inches)	915 (36)	800 (30)	610 (24)

\* Maximum allowable rock size

The modified size and gradation of R-5M, R-6M, and R-7M are plotted against HEC-23 DG-12 class II, III, and IV respectively in Figure A-6 through A-8. The modified size and gradation of R-5M, R-6M, and R-7M coincide with HEC-23 recommended classes for PGR and thus can be used for PGR applications.

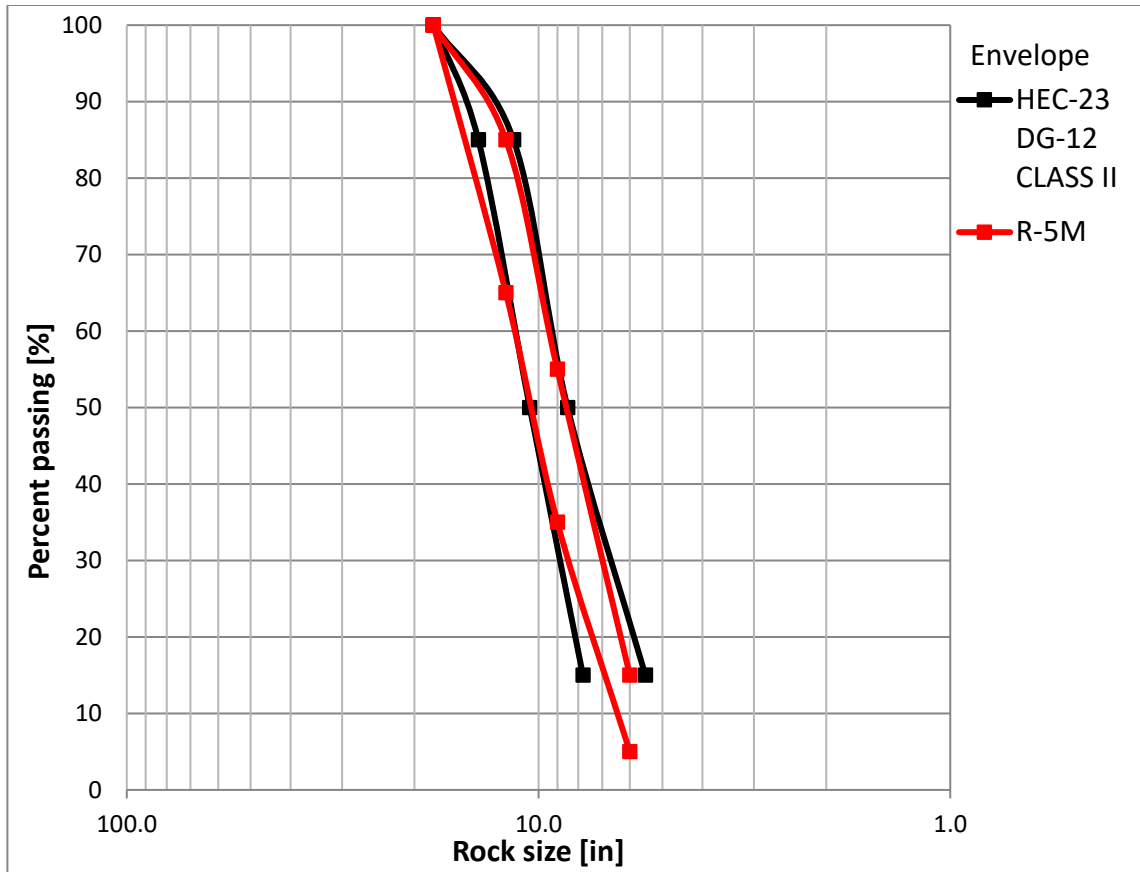

Figure A-6: Rocks Gradation of R-5M and HEC-23 DG-12 Class II

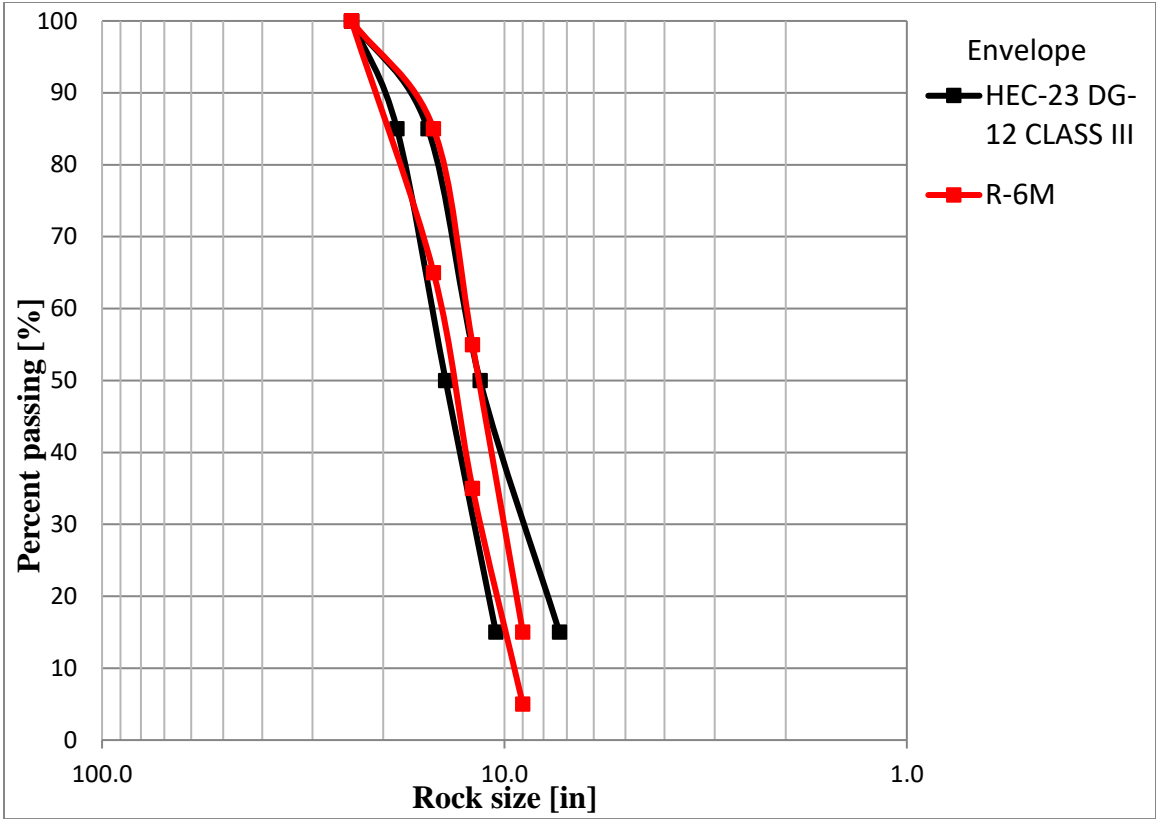

Figure A-7: Rocks Gradation of R-6M and HEC-23 DG-12 Class III

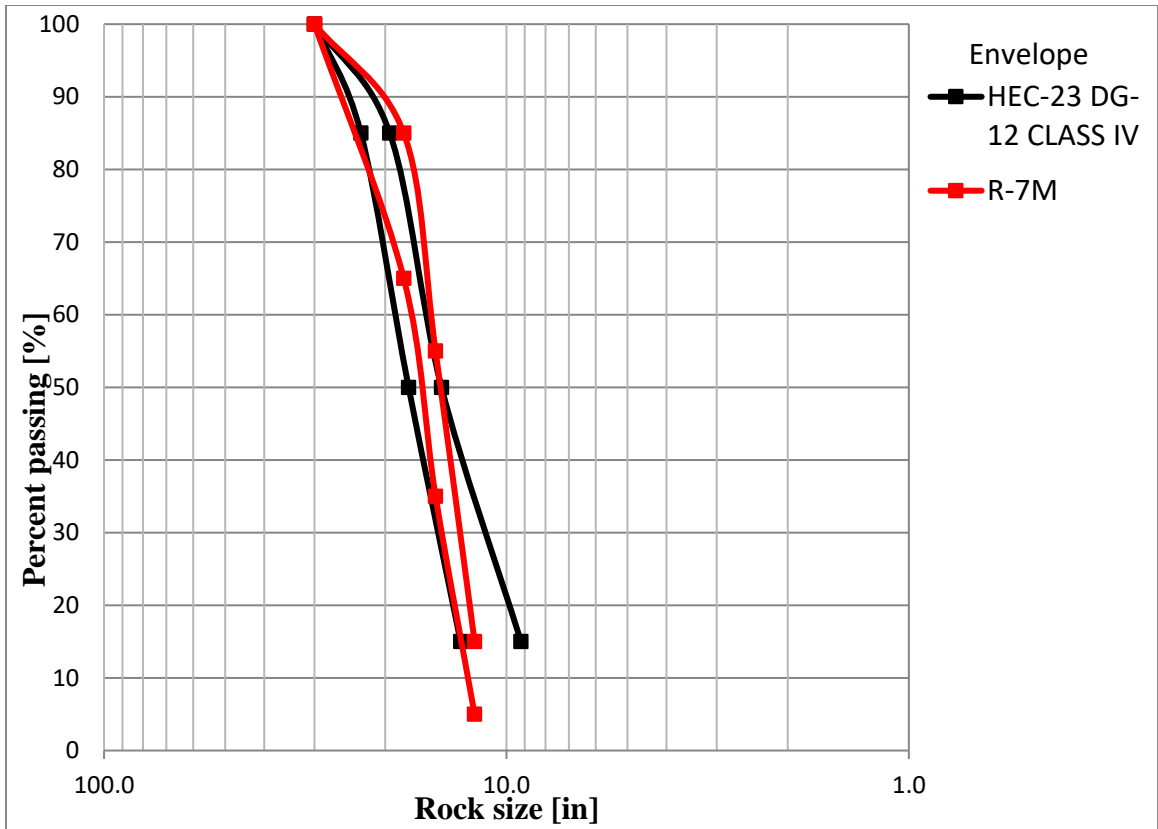

Figure A-8: Rocks Gradation of R-7M and HEC-23 DG-12 Class IV

## APPENDIX B “TEST RESULTS OF EXPERIMENTAL RESEARCH ON GROUT DESIGN MIX”

---

### B-1 Introduction

Based on guidance developed by Federal Waterway Engineering and Research Institute (BAW) in Germany, HEC 23 Design Guidelines 12 “Partially Grouted Riprap at Bridge Piers” (1, 2) provided general requirements for grouting materials. An experimental research study was established in this Task 2.2 research program to develop grout trial design mixes to be used in the scour countermeasure construction of partially grouted riprap “in the dry” and “in the wet” at the selected scour critical bridge in District 6-0. In the experimental research, a number of grout quality control tests have been conducted and a correlation between the European Flow Table Test and ASTM C 161 “Standard Test Method for Slump of Self-Consolidating Concrete” was established. The experimental test results are presented in this task report. Recommendations for grout mix design for construction in the wet and in the dry are presented with general guidance of grouting materials for the design guidelines of partially grouted riprap for piers and abutment (Task 2.5).

### B-2 HEC-23 Design Guidelines 12 (HEC23 DG-12) For Grout Materials

General requirements for grouting materials for partially grouted riprap (PGR) presented in HEC-23 DG-12 are based on the guidance developed by the Federal Waterway Engineering and Research Institute (BAW) in Germany (1, 2, 3). For PGR application, only Portland cement-based grout is applicable. HEC-23 DG-12 target basic grout mix for one cubic yard of grout is presented in Table B-1

Table B-1: HEC 23 DG 12 Target Basic Grout Mix for one Cubic Yard

<b>Material</b>	<b>Quantity by weight (pounds)</b>
Ordinary Portland cement	740 to 760
Fine concrete aggregate (sand), dry	1,180 to 1,200
¼" crusher chips (very fine gravel), dry	1,180 to 1,200
Water	420 to 450

Air entrained	5 to 7% of cement weight
Anti-washout additive (Sicotan®) (used only for placement underwater)	6 to 8

The targeted grout mix should result in a wet grout density ranging from 120 to 140 lb/ft<sup>3</sup>. Wet densities outside this range should be rejected and the mix should be re-evaluated for material properties of the individual constituents. Standard European Flow Table Test “Tap-Test” is used to evaluate grout quality and consistency. The target values for the Tap-Test measurements are presented in Table 2. For construction in the wet, the grout mix should result in a maximum permissible mass loss of grout materials of 6 percent.

Table B-2: Tap-Test Target Values Measurement

<b>For placement “in the dry”</b>	13.4 to 15 inch without tapping
	19.7 to 21.25 inch after 15 taps
<b>For placement “in the wet”</b>	11.8 to 13.4 inch without tapping
	13.4 to 15 inch after 15 taps

### B-3 Experimental Research Program

#### B-3.1 Objectives

The objectives of the laboratory experimental research program are as follows:

- 1) To develop grout trial design mixes to be used in the scour countermeasure construction of PGR “in the dry” and “in the wet” at the selected scour critical bridge in District 6-0.
- 2) To evaluate the impact of water cement ratio (w/c) and anti-washout admixture (AWA) on the flowability of grout.
- 3) To establish a correlation between the European Flow Table Test “Tap-Test” and ASTM C 161 “Standard Test Method for Slump of Self-Consolidating Concrete” “Spread-Test”.

#### B-3.2 Experimental Test Program

HEC-23 DG-12 average target basic grout mix for one cubic yard of grout was used in the experimental test program. Table B-3 presents the experimental test program target trial grout mix for one cubic yard of grout placement in the wet or in the dry.

Table B-3: Experimental Test Program Target Trial Grout Mix for one Cubic Yard

Material	Quantity by weight (pounds)
Ordinary Portland cement	750
Fine Aggregate, dry	1,190
¼" crusher chips (coarse aggregate), dry	1,190
Water-Cement Ratio (w/c)	0.40 to 0.45
Air entrained	1.25 to 6.0 oz/100 lb of cement
Anti-washout Admixture (AWA) (used only for placement underwater)	13.0 to 19.0 oz/100 lb of cement

Fifteen trial grout design mixes were produced in the Civil and Environmental Engineering Construction Laboratory, College of Engineering, Temple University. Twelve of the trial grout design mixes intended for grout placement in the wet with varying w/c ratio of 0.40, 0.43, and 0.45, and varying AWA of 13, 15, 17, and 19 oz/100 lb of cement were produced. Note, 13, 15, and 17 oz/100 lb of AWA correspond to HEC-23 DG-12 recommendation of 6, 7, 8 lb of AWA per cubic yard of grout, respectively. In addition, w/c ratio of 0.45 is the maximum recommended by the manufacturer of AWA of MasterMatrix UW 450 (formerly Rheomac UW 450). Whereas 19 oz/100 lb of cement of AWA (corresponding to HEC-23 DG-12 target basic grout mix of 9 lb per cubic yard of grout) is outside the recommended maximum amount of AWA by HEC-23 DG-12 but within the manufacture recommended limits for MasterMatrix UW 450. Further, the air entraining and anti-washout admixtures for each individual w/c ratio were kept constant but differed from one w/c ratio to another. Three-trial grout design mix for placement of grout in the dry with w/c ratio of 0.4, 0.43, and 0.45 without AWA, and constant air training and water-reducing admixtures were produced. Each trial grout design mix was repeated three times for statistical consistency. This led to the production of forty-five batches of freshly mixed grout in the laboratory. All the trial grout design mixes were within the recommended average target basic grout mix for one cubic yard of grout by HEC 23 DG 12. Table B-4 presents the trial batch mix design for grout placement in the wet. Table B-5 presents the trial batch mix design for grout placement in the dry. Each trial batch mix of grout was tested in accordance with the following procedures:

- European Flow Table Test “Tap-Test” shown in photo B-1; it consists of portable tap table of 11.63 square inch (75 square centimeters); a slump cone with base diameter of 7.87 inch (20 centimeter), top diameter of 3.94 inch (10 centimeter), and height of 7.87 inch (20 centimeter); and a special wood taping rod. The cone is placed on the table with the surface completely dry. The cone filled with grout mixture in two layers and each layer

rodded for 25 times. The rod is used to smooth off the top of the grout so it is flush with the cone. The slump cone is picked up straight off the table. The diameter of the grout mix on the table is measured and recorded. The table is tapped up and down 15 times and the grout mix diameter is measured and recorded.

- ASTM C 1611 “Standard Test Method for Slump of Self-Consolidating Concrete” “Spread-Test” shown in photo B2
- US Army of Engineers Standards CRD-C 61 – 89A “Test Method for Determining the Resistance of Freshly Mixed Concrete to Washing Out in Water”. Only for grout placement in the wet and shown in photo B-3
- ASTM C39 “Standard Test Method for Compressive Strength of Cylindrical Concrete Specimens”.
- ASTM C231 “Standard Test Method for Air Content of Freshly Mixed Concrete by the Pressure Method”.



Photo B-1: European Flow Table Test “Tap-Test”



Photo B-2: ASTM C 1611 "Standard Test Method for Slump of Self-Consolidating Concrete"  
"Spread-Test"



Photo B-3: US Army of Engineers Standards CRD-C 61 – 89A “Test Method for Determining the Resistance of Freshly Mixed Concrete to Washing Out in Water”

### B-3.3 Materials

- Cement – Type II Portland cement that meets the chemical and physical requirements of ASTM C-150 “Standard Specification for Portland Cement,” and AASHTO M85 “Standard Specification for Portland Cement (Chemical and Physical)”
- Fine aggregate – meets Type “A” of PennDOT Table A Section 703.1. Figure 1 presents the average grain size distribution for the fine aggregate used in the grout mix. Appendix A presents the test data of the grain size distribution.
- Coarse Aggregate – meets AASHTO No. 8 of PennDOT Table C Section 703.2. The aggregate were washed thoroughly before being used in the grout mix. Figure 2 presents the average grain size distribution for AASHTO No. 8 coarse aggregate used in the grout mix. Appendix A presents the test data of the grain size distribution.
- Water – meets PennDOT Section 720.1.
- Air Entraining Admixture – Master Air AE 90 “Air-Entraining Admixture” (formerly MB-AE 90) meets AASHTO M 154 of PennDOT Section 711.3. The BASF product specification for Master Air AE 90 is presented in Appendix B.
- Water-Reducing Admixture – MasterGlenium 7500 “Full-Range Water-Reducing Admixture” (formerly GLENIUM 7500) meets AASHTO M 194 of PennDOT Section 711.3. The BASF product specification for MasterGlenium 7500 is presented in Appendix B.
- Anti-Washout Admixture – MasterMatrix UW 450 “Anti-Washout Admixture” (formerly Rheomac UW 450) meets AASHTO M 194 of type S. The BASF product specification for MasterMatrix UW 450 is presented in Appendix B

Table B-4: Trial Batch Mix Design for Grout Placement in the Wet

Mix	w/c Ratio	AWA, oz/100 lb of cement	Cement, lb	Fine Aggregate, lb	Coarse Aggregate, lb	Air Entrainment Admixture, oz/100 lb of cement	Water Reducer Admixture, oz/100 lb of cement
R.A.1	0.4	13	25	40	40	6	4.5
R.A.2	0.4	13	25	40	40	6	4.5
R.A.3	0.4	13	25	40	40	6	4.5
R.B.1	0.4	15	25	40	40	6	4.5
R.B.2	0.4	15	25	40	40	6	4.5
R.B.3	0.4	15	25	40	40	6	4.5
R.C.1	0.4	17	25	40	40	6	4.5
R.C.2	0.4	17	25	40	40	6	4.5
R.C.3	0.4	17	25	40	40	6	4.5
R.J.1	0.4	19	25	40	40	6	4.5
R.J.2	0.4	19	25	40	40	6	4.5
R.J.3	0.4	19	25	40	40	6	4.5
R.D.1	0.43	13	25	40	40	3.5	3
R.D.2	0.43	13	25	40	40	3.5	3
R.D.3	0.43	13	25	40	40	3.5	3
R.E.1	0.43	15	25	40	40	3.5	3
R.E.2	0.43	15	25	40	40	3.5	3
R.E.3	0.43	15	25	40	40	3.5	3
R.F.1	0.43	17	25	40	40	3.5	3
R.F.2	0.43	17	25	40	40	3.5	3
R.F.3	0.43	17	25	40	40	3.5	3
R.K.1	0.43	19	25	40	40	3.5	3
R.K.2	0.43	19	25	40	40	3.5	3
R.K.3	0.43	19	25	40	40	3.5	3
R.G.1	0.45	13	25	40	40	1.5	1
R.G.2	0.45	13	25	40	40	1.5	1
R.G.3	0.45	13	25	40	40	1.5	1
R.H.1	0.45	15	25	40	40	1.5	1
R.H.2	0.45	15	25	40	40	1.5	1
R.H.3	0.45	15	25	40	40	1.5	1
R.I.1	0.45	17	25	40	40	1.5	1
R.I.2	0.45	17	25	40	40	1.5	1
R.I.3	0.45	17	25	40	40	1.5	1
R.L.1	0.45	19	25	40	40	1.5	1
R.L.2	0.45	19	25	40	40	1.5	1
R.L.3	0.45	19	25	40	40	1.5	1

Table B-5: Trial Batch Mix Design for Grout Placement in the Dry

Mix	w/c Ratio	Cement, lb	Fine Aggregate, lb	Coarse Aggregate, lb	Air Entrainment Admixture, oz/100 lb of cement	Water Reducer Admixture, oz/100 lb of cement
Dry 1A	0.4	25	40	40	1.25	0.5
Dry 1B	0.4	25	40	40	1.25	0.5
Dry 1C	0.4	25	40	40	1.25	0.5
Dry 2A	0.43	25	40	40	1.25	0.5
Dry 2B	0.43	25	40	40	1.25	0.5
Dry 2C	0.43	25	40	40	1.25	0.5
Dry 3A	0.45	25	40	40	1.25	0.5
Dry 3B	0.45	25	40	40	1.25	0.5
Dry 3C	0.45	25	40	40	1.25	0.5

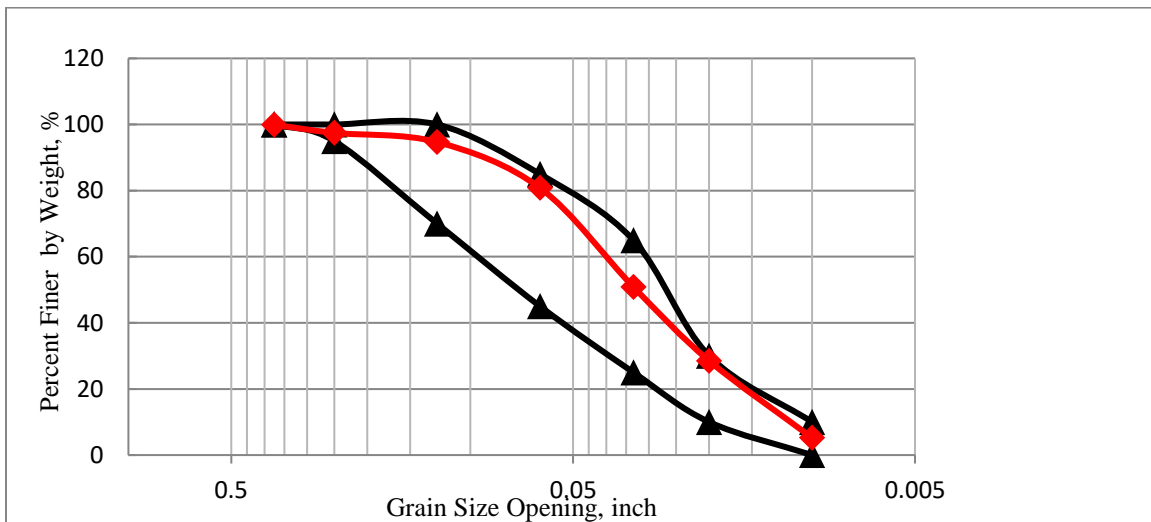

Figure B-1 – Average Grain Size Distribution of Type A Fine Aggregate Used

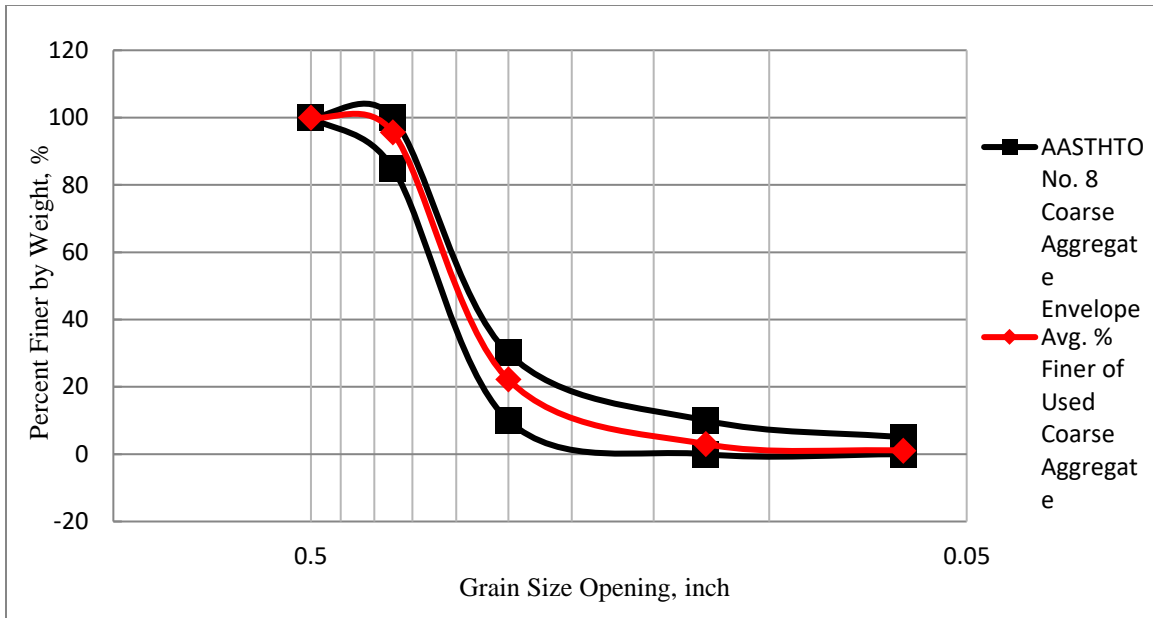

Figure B-2 – Average Grain Size Distribution of AASHTO #8 Coarse Aggregate Used

#### B-3.4 Mixing of Grout Batch

The required quantity of the grout materials and admixtures for each batch mix were weighed in separate containers. The dry material (cement, fine aggregate and coarse aggregate) were placed in the drum of electrically powered one cubic yard portable concrete mixer shown in photo 4 and mixed for five minutes. Then the water, air-entraining admixture, and water-reducing admixture were added to the dry materials of the batch and the grout mixed for five minutes. For grout to be placed in the wet, the anti-washout admixture added last to the mix and the grout mixture were mixed for additional five minutes.



Photo B-4: Concrete Mixer While Mixing Concrete

### B-3.5 Test Results and Discussion

Table B-6 and B-7 summarize the test results of the trial batch mix design for grout placement in the wet and in the dry, respectively. The target values for the Tap-Test measurement and the wet density of the grout were within the statistical variability (+/- 5%) of HEC-23 DG-12 recommendations as shown in Table B-6 and B-7 for grout placement in the wet and in the dry, respectively.

The increase in w/c ratio with various amount of AWA was shown to increase the Tap-Test without tapping and the Spread-Test measurements of freshly mixed grout for grout placement in the wet as shown in Figure B-3 and B-4, respectively. The increase in measurement was higher at higher w/c ratio and lower amount of AWA. Similar behavior shown in Figure 5 was observed after 15 taps for the Tap-Test. However, after 15 taps (Figure B-5) the result was inconsistent and was not

as conclusive as it was for the Tap-Test without tapping and the Spread-Test. It is believed to be due to human variability in tapping the table up and down for 15 times. The influence of varying w/c ratio with various amount of AWA was more noticeable with the Spread-Test (Figure B-4) than with the Tap-Test (Figure B-3). Increasing the amount of AWA reduced the Tap-Test and Spread-Test measurements as shown in Figure B-6, B-7, and B-8. This indicates that increasing the amount of AWA in a grout mix would reduce workability of grout whereas increasing w/c ratio resulted in an increase of grout workability. Similar to w/c ratio, the results were inconsistent and inconclusive for the Tap-Test after 15 taps (Figure B-8) than it was for the Spread-Test. This indicates that the Spread-Test is better suited to measure workability/consistency of freshly mixed grout than the Tap-Test. The effect of AWA on the test measurements was more visible with 0.40 w/c ratio than with 0.45 w/c ratio. This indicates that higher w/c ratio reduces AWA effectiveness in the freshly mixed grout.

For grout placement in the dry, increasing w/c ratio increased the Tap-Test and the Spread-Test measurements as shown in Figures B-9, B-10, and B-11. However, Tap-Test result was consistent and conclusive after 15 taps for grout placement in the dry (Figure B-11) than it was for grout placement in the wet (Figures B-5 and B-8). The difference between grout placement in the wet and in the dry is the addition of AWA. This indicates that the addition of AWA to the freshly mixed grout might negatively affect the result of the Tap-Test after 15 taps. In addition, the influence of varying w/c ratio was more noticeable with the Spread-Test (Figure B-9) than with the Tap-Test (Figure B-10). Therefore, the Spread-Test is a suitable test to measure the workability/consistency of freshly mixed grout for grout placement in the dry. Further, within statistical variability and for grout placement in the dry, the trial grout mix with 0.40 w/c ratio was in better agreement with HEC-23 DG-12 target values for the Tap-Test measurement and the wet density than for 0.43 and 0.45 w/c ratio.

As shown in Figures B-12 and B-13, the total mass loss of grout materials was less than 6 percent for grout placement in the wet, and it was within the recommendation of HEC-23 DG-12. As expected, increasing AWA resulted in reducing the mass loss. However, for the same amount of HEC-23 DG-12 recommended amount of AWA (13 to 17 oz/100 lb of cement) the reduction of mass loss was more noticeable with 0.40 w/c ratios than 0.43 and 0.45 w/c ratios. In addition, increasing AWA from 17 oz/100 lb of cement (equivalent to HEC-23 DG-12 max value of 8 lb per cubic yard of concrete) to 19 oz/100 of cement (equivalent to 9 lb per cubic yard of concrete) the mass loss was not as noticeable for 0.45 w/c ratios as it was for 0.40 and 0.43 water-cement ratio. Further, the workability of the grout was substantially reduced at low water w/c ratio and at an amount of AWA beyond the max-recommended amount by HEC-23 DG-12. Thus, 0.40 w/c ratio with 17 oz/100 lb of cement of AWA seemed to be a better grout design mix than the other tested trial grout mix designs for grout placement in the wet.

Figures B-14 through B-17 represent the correlation between the Tap-Test without tapping and the Spread-Test with various w/c ratios and each individual AWA amount for grout placement in the wet. The correlation coefficient "R" ( $R^2$  = Coefficient of Determination) varied between 1 and 0.91. Similarly, Figures B-18 through B-20 represent the correlation between the Tap-Test

without tapping and the Spread-Test with various amounts of AWA and each individual w/c ratio for grout placement in the wet. The correlation coefficient "R" varied between 0.93 and 0.96. This indicates that within statistical variation there is a very close correlation between the Spread-Test and the Tap-Test without tapping. In addition, the w/c ratio or the amount of AWA has no effect on the correlation between the two types of tests for grout workability and consistency.

Further, based on the correlation relation between the two types of test, the Spread-Test values measurement varied between 13.5 to 16.4 inches for grout placement in the wet (corresponding to HEC-23 DG-12 Tap-Test target values measurements of 11.8 to 13.4 inches without tapping). Figures B-21 through B-24 represent the correlation between the Tap-Test after 15 taps and the Spread-Test with various w/c ratios and each individual amount of AWA for grout placement in the wet. The correlation coefficient "R" varied between 0.84 and 0.99. Similarly, Figures B-25 through B-27 represent the correlation between the Tap-Test after 15 taps and the Spread-Test with various amounts of AWA and each individual w/c ratios for grout placement in the wet. The correlation coefficients "R" for w/c ratio of 0.40, 0.43, and 0.45 were 0.12, 0.98, and 0.95, respectively. This indicates that for a given w/c ratio and various amounts of AWA the correlation between the Spread-Test and the Tap-Test after 15 taps was poor. Further, tapping of the Spread-Test is impacted by AWA. Thus, Spread-Test is better suited to measure workability/consistency of freshly mixed grout than the Tap-Test after 15 taps. Based on the correlation relation between the two types of tests, the Spread-Test values measurement varied between 12.5 to 14.5 inches for grout placement in the wet that correspond to HEC-23 DG-12 Tap-Test target values measurements of 13.4 to 15 inches after 15 taps. Thus, the Spread-Test target values measurements of 12.0 to 15.0 inches should provide reasonable grout workability and consistency for grout placement in the wet.

The correlation between the Tap-Test without tapping and the Spread-Test with various w/c for grout placement in the dry is shown in Figure B-28. The correlation coefficient "R" is 0.98. Similarly, Figure B-29 represents the correlation between the Tap-Test after 15 taps and the Spread-Test with various w/c ratios for grout placement in the dry. The correlation coefficient "R" is 0.85. This indicates that within statistical variation, there is a very close correlation between the Spread-Test and the Tap-Test without tapping whereas; the correlation is not as close when the Spread-Test is compared to the Tap-Test after 15 taps. It is believed to be due to human variability in tapping the table up and down for 15 times. In addition, the w/c ratio has no effect on the correlation between the two types of tests for grout workability and consistency. Further, based on the correlation relation between the two types of test the Spread-Test values measurement varied between 15.4 to 16.8 inches for grout placement in the dry that correspond to HEC-23 DG-12 Tap-Test target values measurements of 13.4 to 15 inch without tapping. For the HEC-23 DG-12 Tap-Test target values measurements of 19.7 to 21.25 inches after 15 taps, the Spread-Test values measurement were between 15.6 to 17.5 inches for grout placement in the dry. Thus, for grout placement in the dry the Spread-Test target values measurements of 15 to 18 inches should provide reasonable grout workability and consistency.

B-4 Conclusion and Recommendation

Based on the experimental test results, all the trial batch mix designs for grout placement in the dry or in the wet were within HEC-23 DG-12 parameters for basic grout mix and the target values for grout workability and consistency. Any of the trial batch design grouts presented in this research are adequate to be used in the scour countermeasure of PGR “in the wet” and “in the dry” at the selected scour critical bridge in District 6-0.

Increasing the w/c ratio increased the workability and consistency, and the loss of mass by weight of the grout. However, within the manufacturer requirements, increasing the dose of AWA resulted in reducing workability and the loss of mass by weight. The target value of a maximum permissible mass loss of grout materials of 6 percent is achievable within the manufacturer requirements and low w/c ratio.

Within the statistical variation, there is a strong correlation between ASTM C 1611 “Standard Test Method for Slump of Self-Consolidating Concrete” “Spread-Test” and the European Flow Table Test “Tap-Test” without tapping. The correlation coefficient “R” for grout placement in the wet or in the dry varied between 1.0 and 0.91. On the other hand, due to human variability in tapping the table up and down for 15 times the correlation between the Tap-Test after 15 taps and ASTM C 1611 “Spread-Test” was not as strong. Thus, ASTM C 1611 “Spread-Test” is a better test to measure workability/consistency of freshly mixed grout. Further, due to the fact that European Flow Table Test is not commonly available for purchase in the United States and ASTM C 1611 is a standard test used in the concrete industry, the ASTM C 1611 “Standard Test Method for Slump of Self-Consolidating Concrete” “Spread-Test” is well suited for United States.

As a result of this experimental research program, it is recommended to the State of Pennsylvania and District 6-0 that the basic grout mix for one cubic yard of grout to be used in PGR in the wet or in the dry is as presented.

<b>Material</b>	<b>Quantity by weight for one cubic yard of grout, pounds</b>
Portland cement, Type I or Type II	740 to 760
Fine Aggregate, dry	1,180 to 1,200
¼” crusher chips or AASHTO No. 8 (coarse aggregate), dry	1,180 to 1,200
Water-Cement Ratio (w/c)	0.40 to 0.45
Air entrained Admixture	Manufacturer Recommendation

Water-Reducing Admixture	Manufacturer Recommendation
Anti-washout Admixture (AWA) (used only for placement underwater)	Manufacturer Recommendation

<b>Material</b>	<b>Quantity by weight for one cubic yard of grout, pounds</b>
Portland cement, Type I or Type II	740 to 760
Fine Aggregate, dry	1,180 to 1,200
¼" crusher chips or AASHTO No. 8 (coarse aggregate), dry	1,180 to 1,200
Water-Cement Ratio (w/c)	0.40 to 0.45
Air entrained Admixture	Manufacturer Recommendation
Water-Reducing Admixture	Manufacturer Recommendation
Anti-washout Admixture (AWA) (used only for placement underwater)	Manufacturer Recommendation

- The targeted grout mix should result in a wet grout density ranging from 120 to 140 lb/ft<sup>3</sup>. Wet densities outside this range should be rejected and the mix re-evaluated for material properties of the individual constituents.
- The targeted grout mix should result in a minimum air content of 6% in the plastic state.
- For construction in the wet and using US Army of Engineers Standards CRD-C 61 – 89A “Test Method for Determining the Resistance of Freshly Mixed Concrete to Washing Out in Water”, the grout mix should result in a maximum permissible mass loss of grout materials of 6 percent.
- ASTM C 1611 “Standard Test Method for Slump of Self-Consolidating Concrete” “Spread-Test” is used to evaluate grout quality and consistency. The target values for the Spread-Test measurements are presented in the Table below.

<b>For placement “in the dry”</b>	15.0 to 18.0 inches
<b>For placement “in the wet”</b>	12.0 to 15.0 inches

Table B-6: Test Results of Trial Batch Mix Design for Grout Placement in the Wet

Mix	w/c Ratio	AWA, oz/100 lb of cement	Avg. Wet Density of Grout, Lb/ft <sup>3</sup>	Avg. Grout Compressive Strength, psi	Ave. Air Content %	European Flow Table Test "Tap-Test"						ASTM C1611 "Spread-Test"			CRD-C 61 – 89A		
						Without Tapping			After 15 Taps			Avg. Dia., Inch	Avg.	Std. Dev.	Mass Loss, %	Ave.	Std. Dev.
						Avg. Dia., Inch	Avg.	Std. Dev.	Avg. Dia., Inch	Avg.	Std. Dev.						
R.A.1	0.40	13	138	6580	7.9	11.61	11.81	0.20	13.78	13.78	0.20	13.19	13.45	0.30	5.1	5.10	0.00
R.A.2	0.40	13	137	5663	7.9	12.01			13.98			13.78					
R.A.3	0.40	13	139	6270	7.9	11.81			13.58			13.39					
R.B.1	0.40	15	140	6037	6.4	11.42	11.52	0.10	13.58	13.61	0.15	12.99	13.19	0.20	4.04	4.29	0.36
R.B.2	0.40	15	139	6127	6.4	11.61			13.78			13.19					
R.B.3	0.40	15	140	5943	6.4	11.52			13.48			13.39					
R.C.1	0.40	17	141	6757	8.6	11.02	11.19	0.37	13.48	13.54	1.29	13.19	12.93	0.46	4	4.00	0.00
R.C.2	0.40	17	141	6747	8.6	10.93			12.29			12.4					
R.C.3	0.40	17	140	6253	8.6	11.61			14.86			13.19					
R.J.1	0.40	19	139	6053	9.3	10.83	10.76	0.12	13.78	13.98	0.26	12.8	12.86	0.69	3.03	3.03	0.00
R.J.2	0.40	19	140	6187	9.3	10.63			13.88			12.21					
R.J.3	0.40	19	140	6067	9.3	10.83			14.27			13.58					
R.D.1	0.43	13	137	6020	15	12.11	11.94	0.21	14.27	14.14	0.15	13.58	13.88	0.36	6.2	5.90	0.52
R.D.2	0.43	13	137	5430	15	11.71			13.98			14.27					
R.D.3	0.43	13	136	5250	15	12.01			14.17			13.78					

R.E.1	0.43	15	137	5273	15	11.81	11.78	0.06	13.48	13.58	0.17	13.39	13.55	0.15	5.1	5.27	0.15
R.E.2	0.43	15	135	5150	15	11.71			13.78			13.58			5.3		
R.E.3	0.43	15	136	5240	15	11.81			13.48			13.68			5.4		
R.F.1	0.43	17	133	4520	16	11.42	11.68	0.23	13.48	13.48	0.10	13.19	13.32	0.23	5	5.13	0.12
R.F.2	0.43	17	136	5313	16	11.81			13.39			13.19			5.2		
R.F.3	0.43	17	130	4430	16	11.81			13.58			13.58			5.2		

Table B-6: Continue

Mix	w/c Ratio	AWA, oz/100 lb of cement	Avg. Wet Density of Grout, Lb/ft <sup>3</sup>	Avg. Grout Compressive Strength, psi	Ave. Air Content %	European Flow Table Test "Tap-Test"						ASTM C1611 "Spread-Test"			CRD-C 61 – 89A					
						Without Tapping			After 15 Taps			Avg. Dia., Inch	Avg.	Std. Dev.	Avg. Dia., Inch	Avg.	Std. Dev.	Avg. Dia., Inch	Avg.	Std. Dev.
						Avg. Dia., Inch	Avg.	Std. Dev.	Avg. Dia., Inch	Avg.	Std. Dev.									
R.K.1	0.43	19	135	4963	16.1	11.42	11.35	0.12	13.39	13.13	0.30	13.19	13.12	0.12	4.04	4.11	0.08			
R.K.2	0.43	19	138	5033	16.1	11.22			12.8			12.99			4.2					
R.K.3	0.43	19	134	4847	16.1	11.42			13.19			13.19			4.1					
R.G.1	0.45	13	134	5070	11.5	12.5	12.66	0.20	16.14	16.60	0.41	14.67	14.96	0.30	5.37	6.06	0.59			
R.G.2	0.45	13	133	4623	11.5	12.89			16.93			14.96			6.4					
R.G.3	0.45	13	135	4633	11.5	12.6			16.73			15.26			6.4					
R.H.1	0.45	15	137	5347	11.5	11.81	12.04	0.40	15.45	15.65	0.26	14.27	14.40	0.15	5.32	5.34	0.03			
R.H.2	0.45	15	138	5427	11.5	11.81			15.55			14.57			5.32					
R.H.3	0.45	15	140	5033	11.5	12.5			15.94			14.37			5.38					
R.I.1	0.45	17	137	5020	11.5	12.21	11.91	0.30	15.35	15.62	0.23	14.17	14.20	0.06	5.26	5.30	0.03			

R.I.2	0.45	17	136	5110	11.5	11.61			15.75			14.17			5.32		
R.I.3	0.45	17	135	5017	11.5	11.91			15.75			14.27			5.32		
R.L.1	0.45	19	137	5863	11.5	12.21	11.91	0.78	15.75	15.55	0.34	14.17	14.01	0.37	5.43	5.28	0.13
R.L.2	0.45	19	137	5160	11.5	12.5			15.75			14.27			5.2		
R.L.3	0.45	19	138	5120	11.5	11.02			15.16			13.58			5.2		

Table B-7: Test Results of Trial Batch Mix Design for Grout Placement in the Dry

Mix	w/c Ratio	Wet Density of Grout, Lb/ft3	Avg. Grout Compressive Strength, psi	Avg. Air Content %	European Flow Table Test						ASTM C1611-09b		
					Without Tapping			After 15 Taps			Avg. Dia., Inch	Avg.	Std. Dev.
					Avg. Dia., Inch	Avg.	Std. Dev.	Avg. Dia., Inch	Avg.	Std. Dev.			
Dry 1A	0.40	131	4323	9.1	14.07	13.94	0.15	20.47	20.34	0.23	15.35	15.74	0.40
Dry 1B	0.40	134	4483	9.1	13.78			20.08			16.14		
Dry 1C	0.40	134	4816	9.1	13.98			20.47			15.74		
Dry 2A	0.43	132		11.0	16.14	16.08	0.30	20.87	21.0	0.11	18.11	18.10	0.12
Dry 2B	0.43	134		11.0	16.34			21.06			18.31		
Dry 2C	0.43	133		11.0	15.75			21.06			18.11		
Dry 3A	0.45	135		13.0	17.72	17.65	0.12	22.05	22.57	0.45	18.9	18.90	0.00
Dry 3B	0.45	136		13.0	17.72			22.83			18.9		
Dry 3C	0.45	137		13.0	17.52			22.83			18.9		

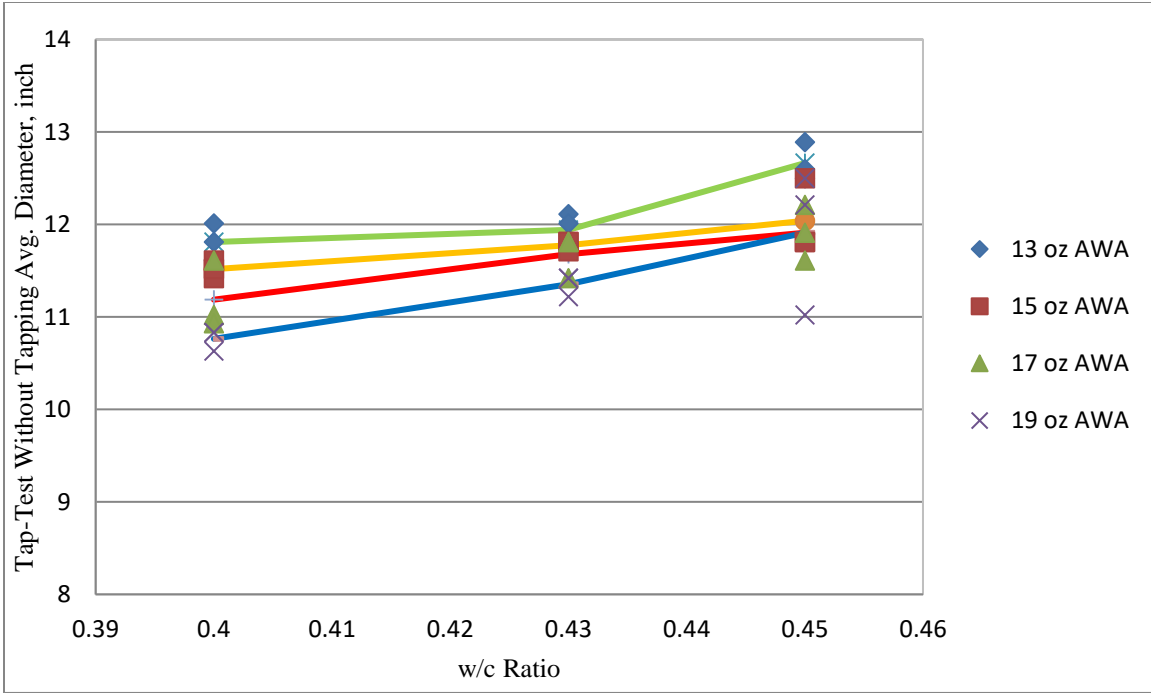

Figure B-3: Effect of w/c Ratio on Tap-Test without Tapping for Grout Placement in the Wet

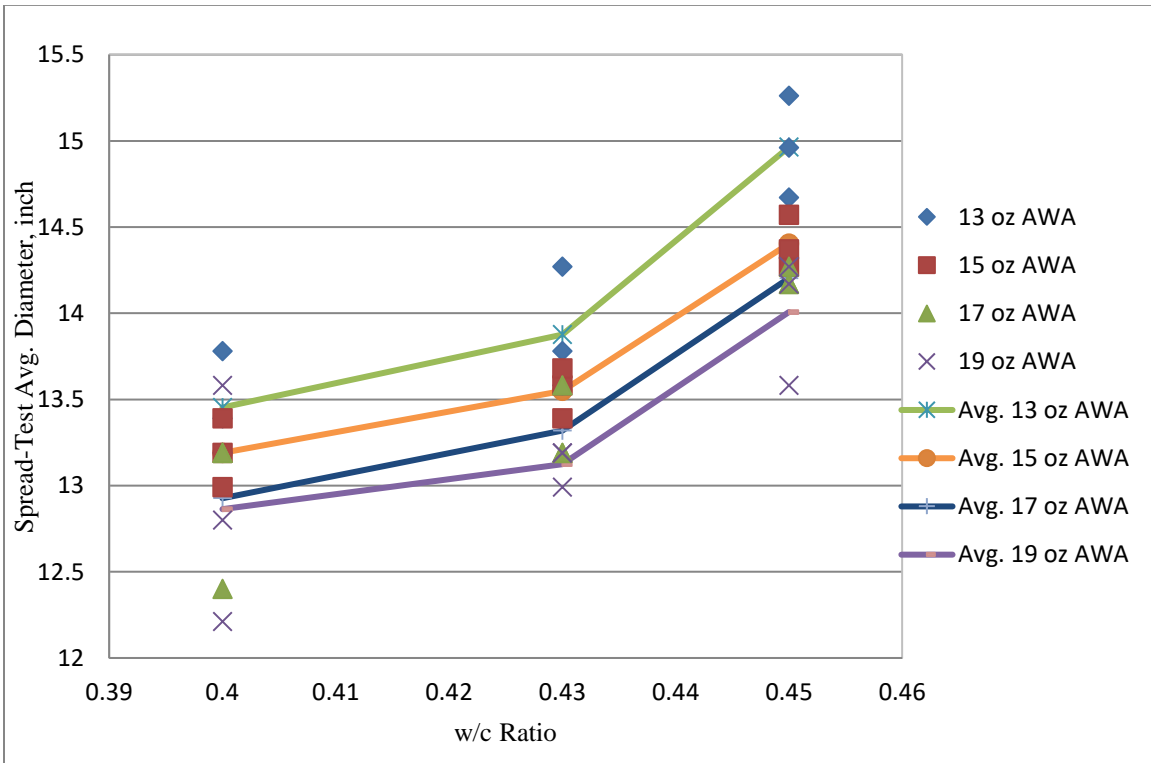

Figure 4: Effect of w/c Ratio on Spread-Test for Grout Placement in the Wet

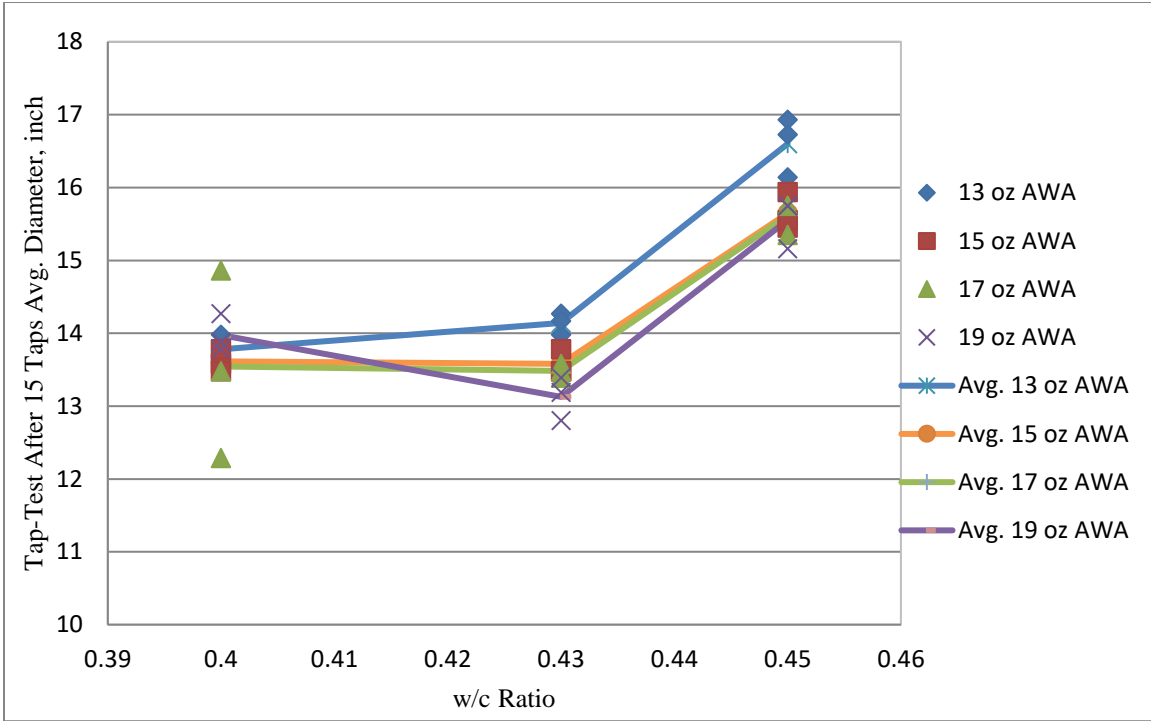

Figure B-5: Effect of w/c Ratio on Tap-Test after 15 Taps for Grout Placement in the Wet

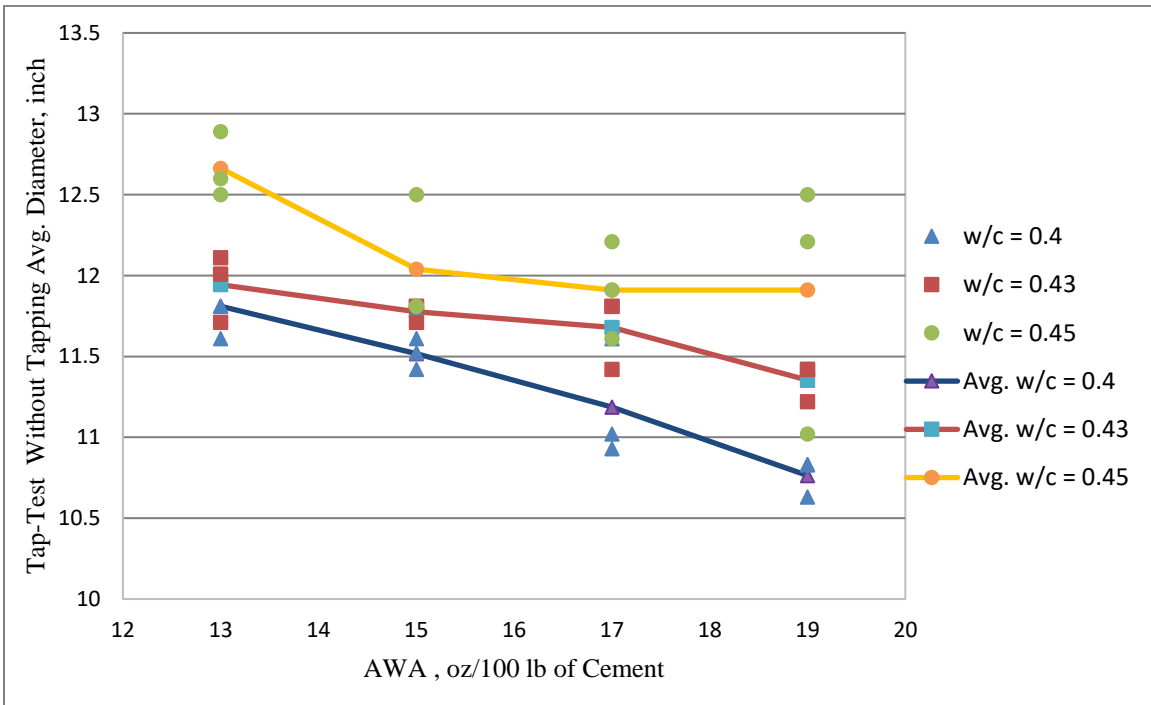

Figure B-6: Effect of AWA on Tap-Test without Tapping for Grout Placement in the Wet

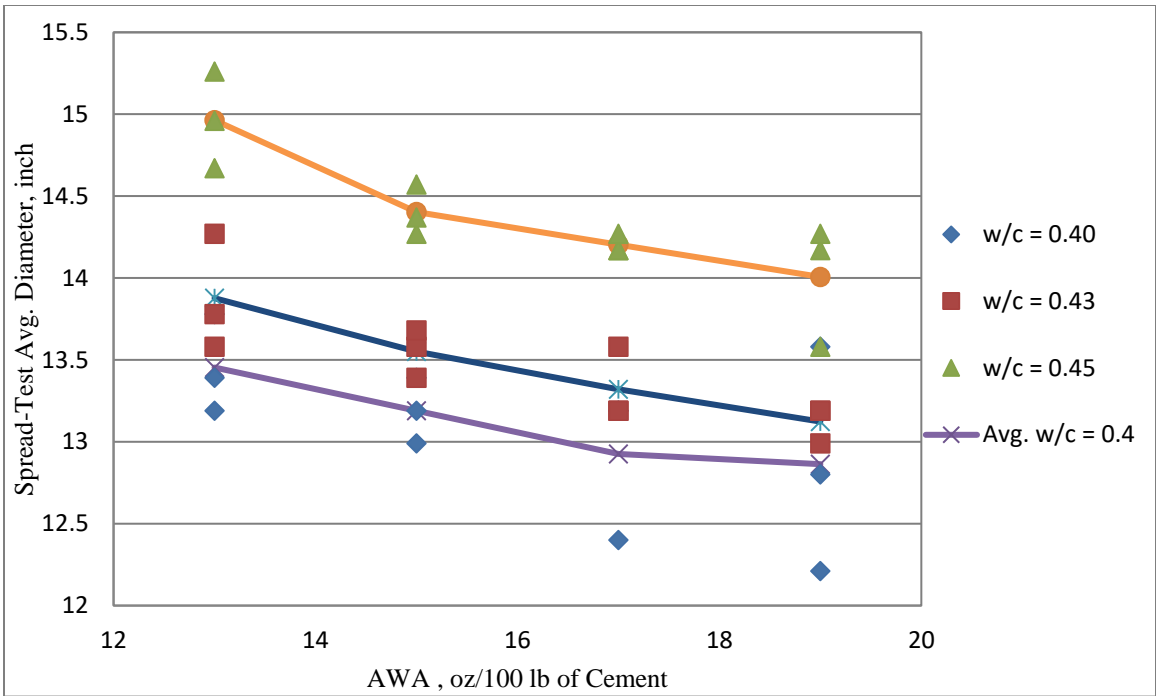

Figure B-7: Effect of AWA on Spread-Test for Grout Placement in the Wet

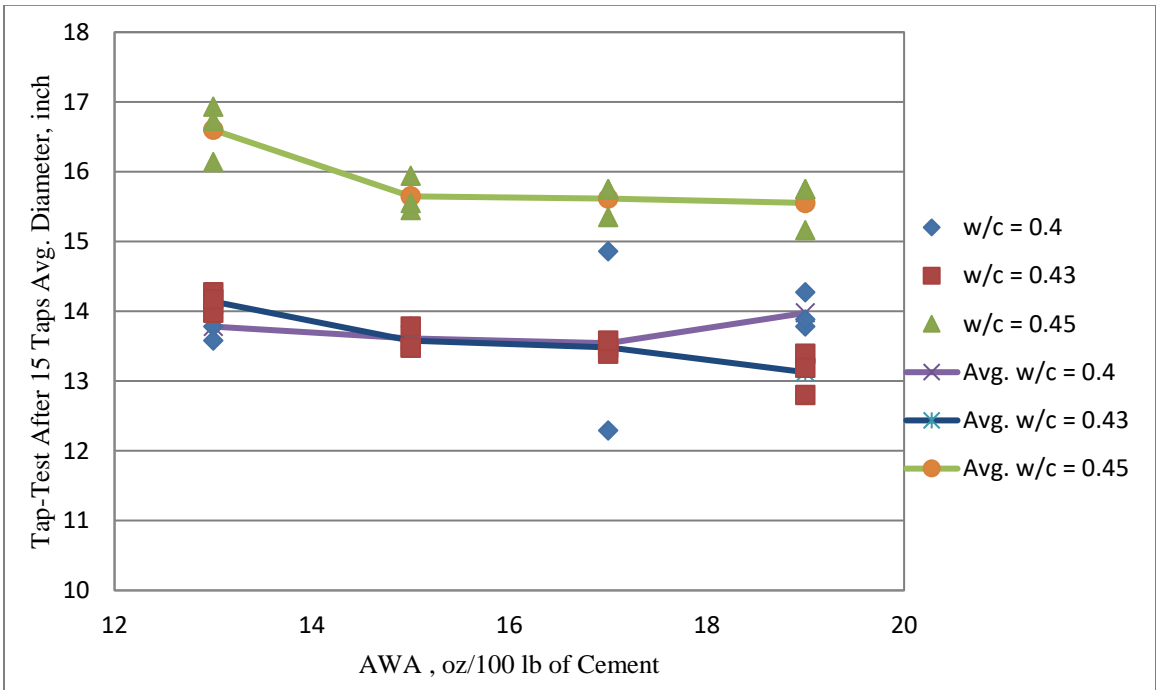

Figure B-8: Effect of AWA on Tap-Test after 15 Taps for Grout Placement in the Wet

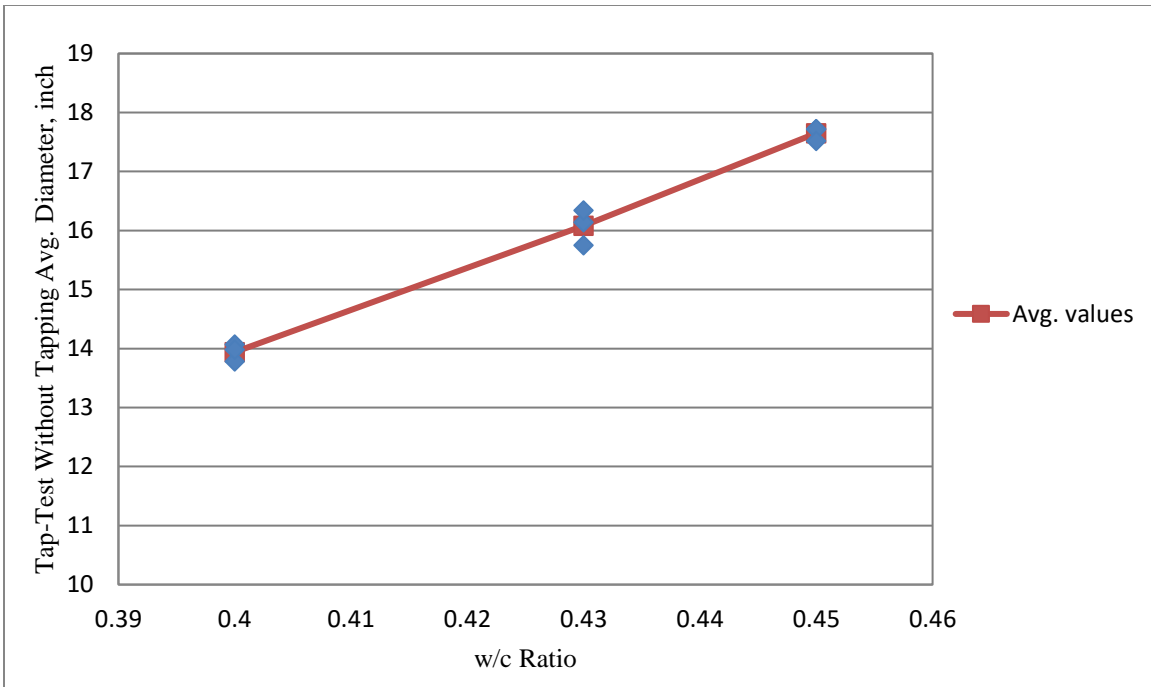

Figure B-9: Effect of w/c Ratio on Tap-Test without Tapping for Grout Placement in the Dry

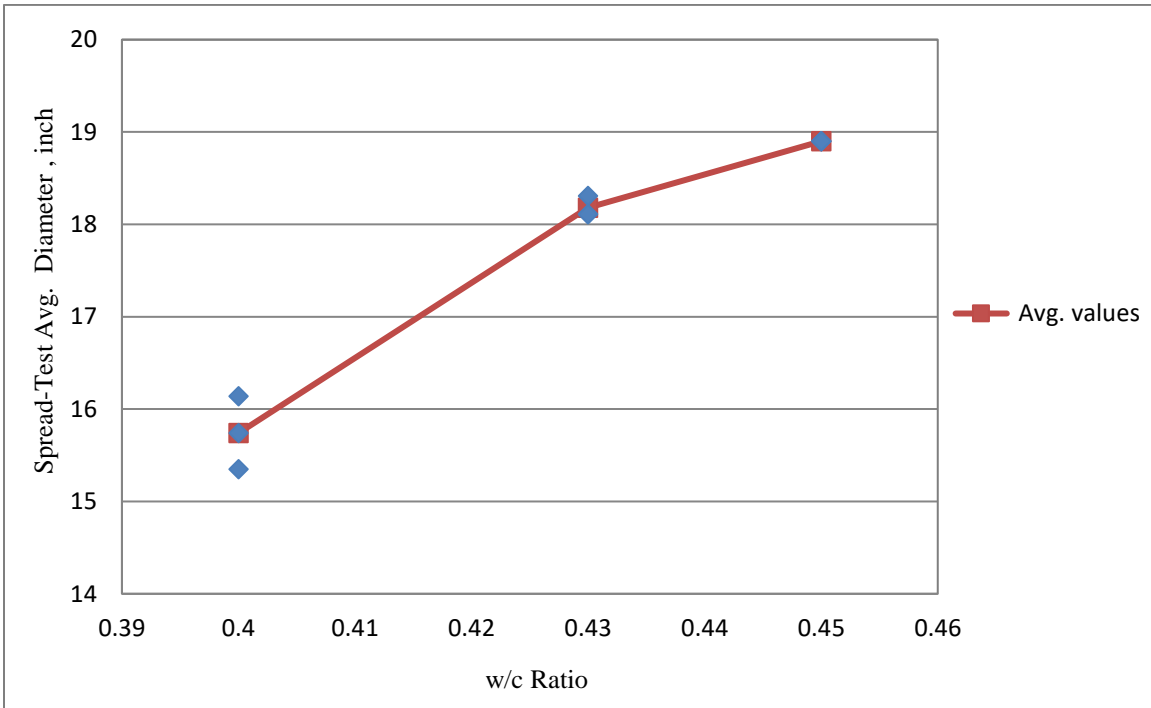

Figure B-10: Effect of w/c Ratio on Spread-Test for Grout Placement in the Dry

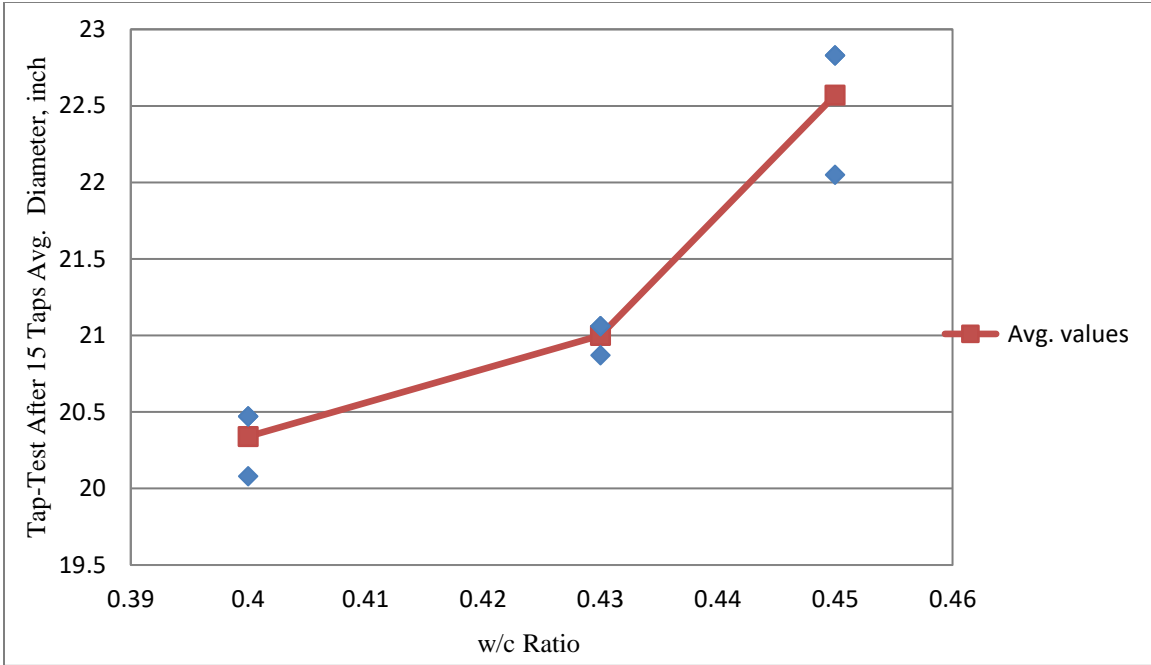

Figure B-11: Effect of w/c Ratio on Tap-Test after 15 Taps for Grout Placement in the Dry

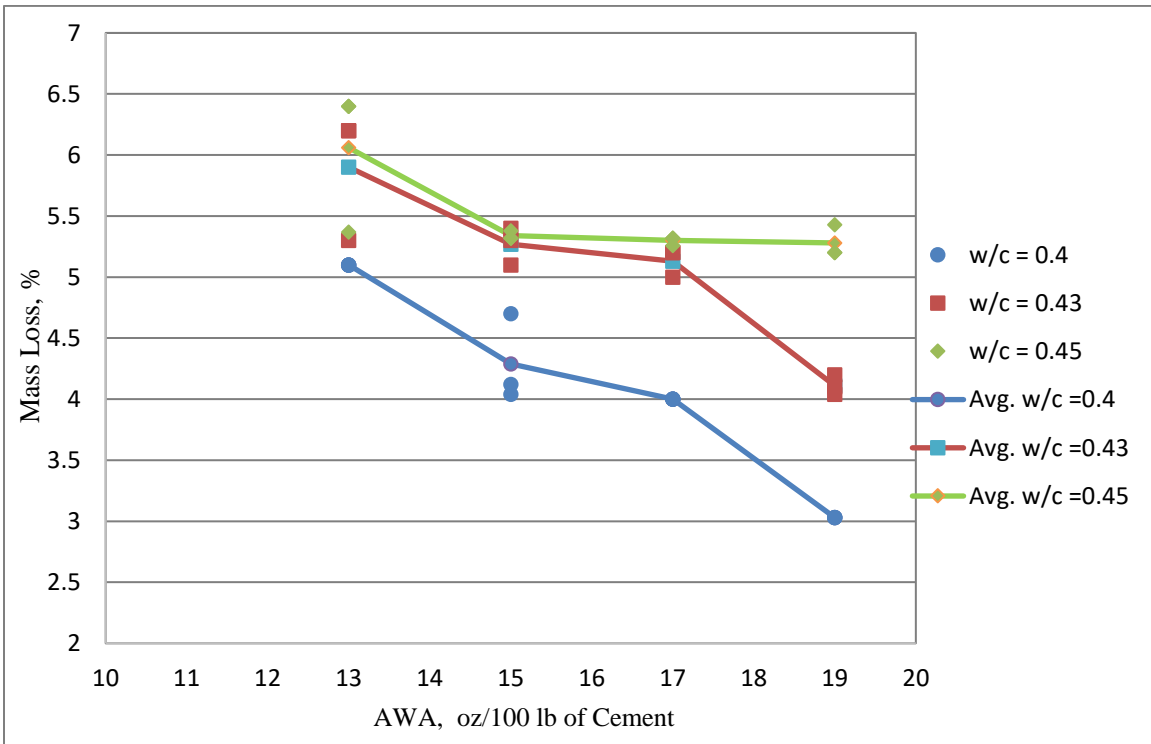

Figure B-12: Effect of AWA on Loss of Mass by Washout

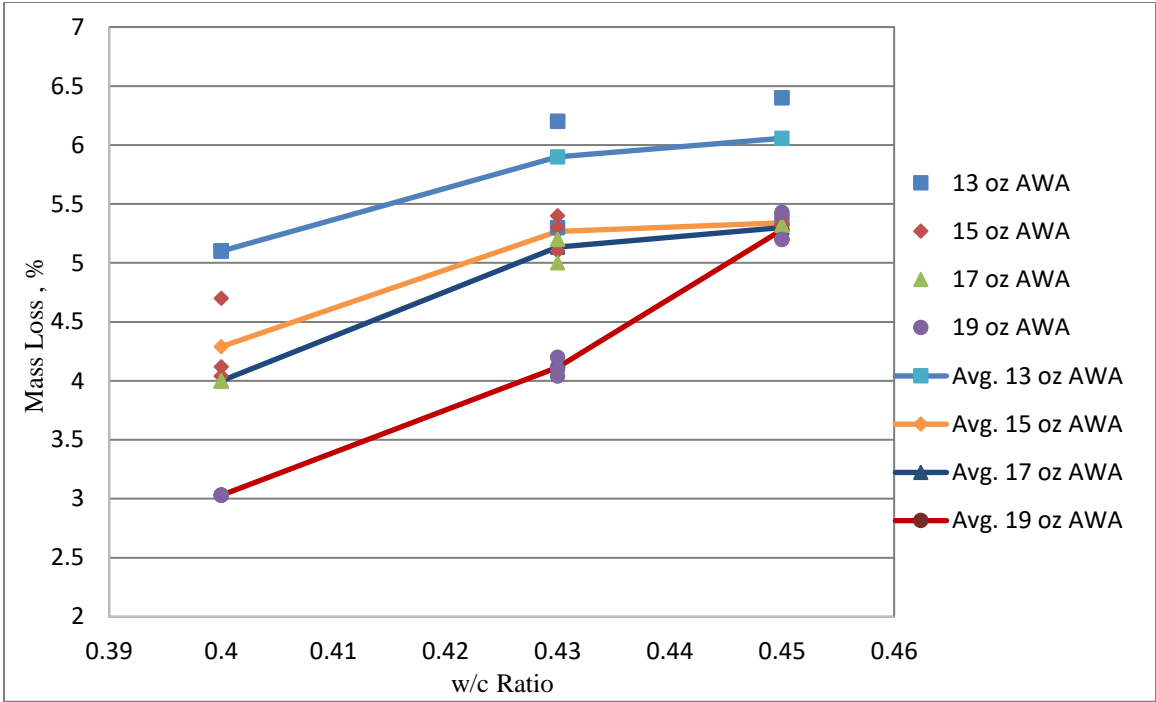

Figure B-13: Effect of w/c Ratio on Loss of Mass by Washout

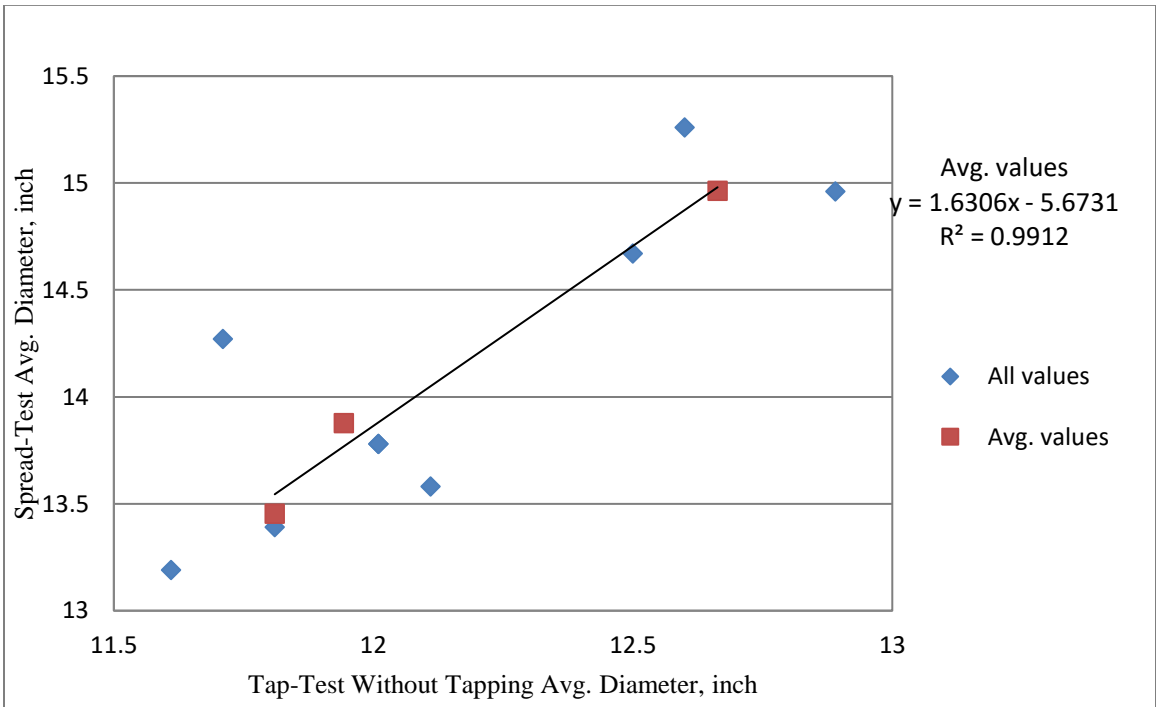

Figure B-14: Correlation Between Tap-Test without Tapping and Spread-Test for AWA = 13oz/100 lb of cement



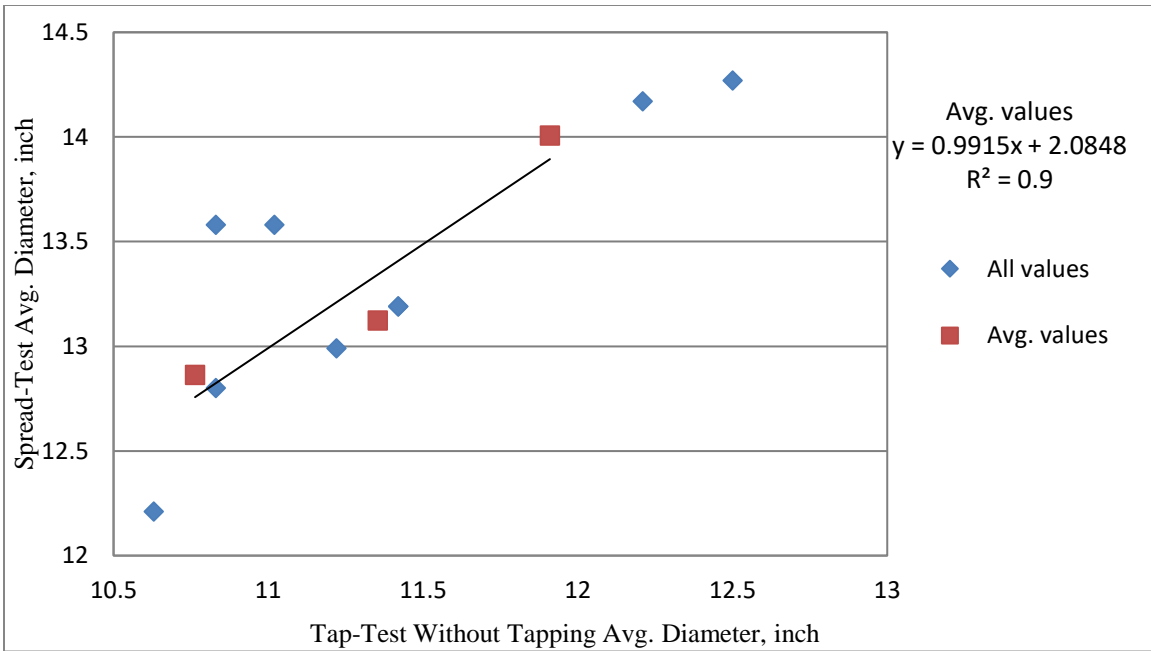

Figure B-17: Correlation between Tap-Test without Tapping and Spread-Test for AWA = 19oz/100 lb of cement

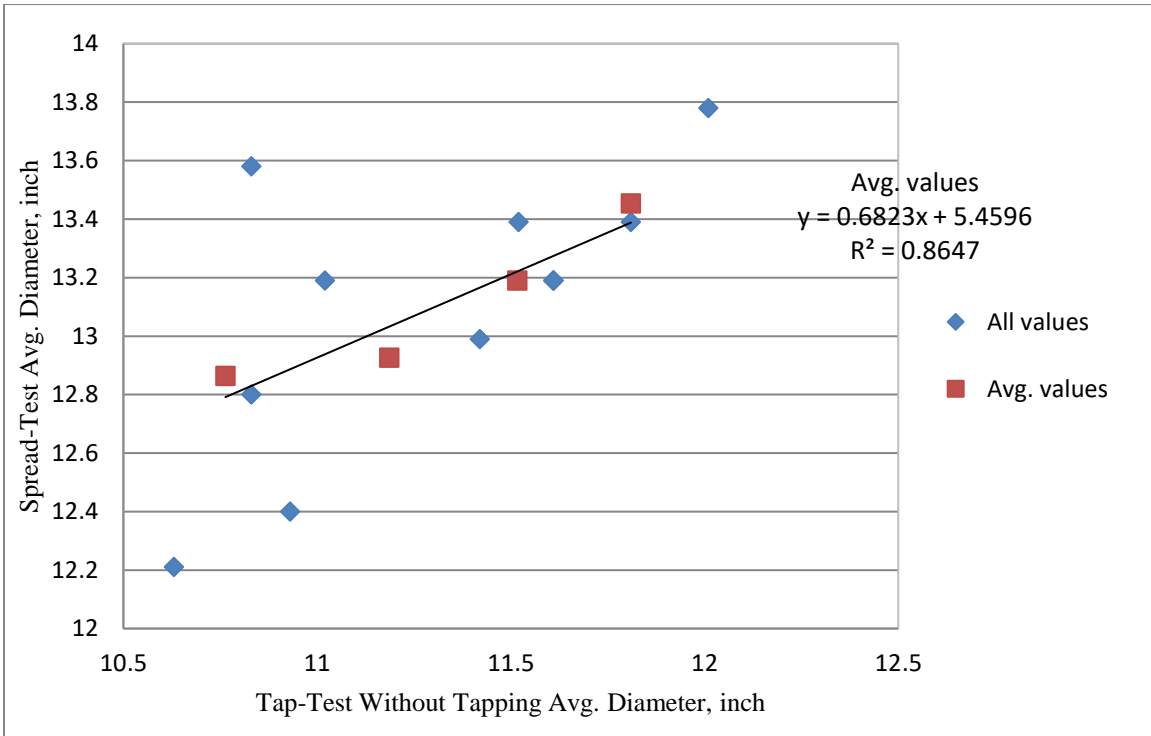

Figure B-18: Correlation between Tap-Test without Tapping and Spread-Test for w/c = 0.40, for Grout Placement in the Wet

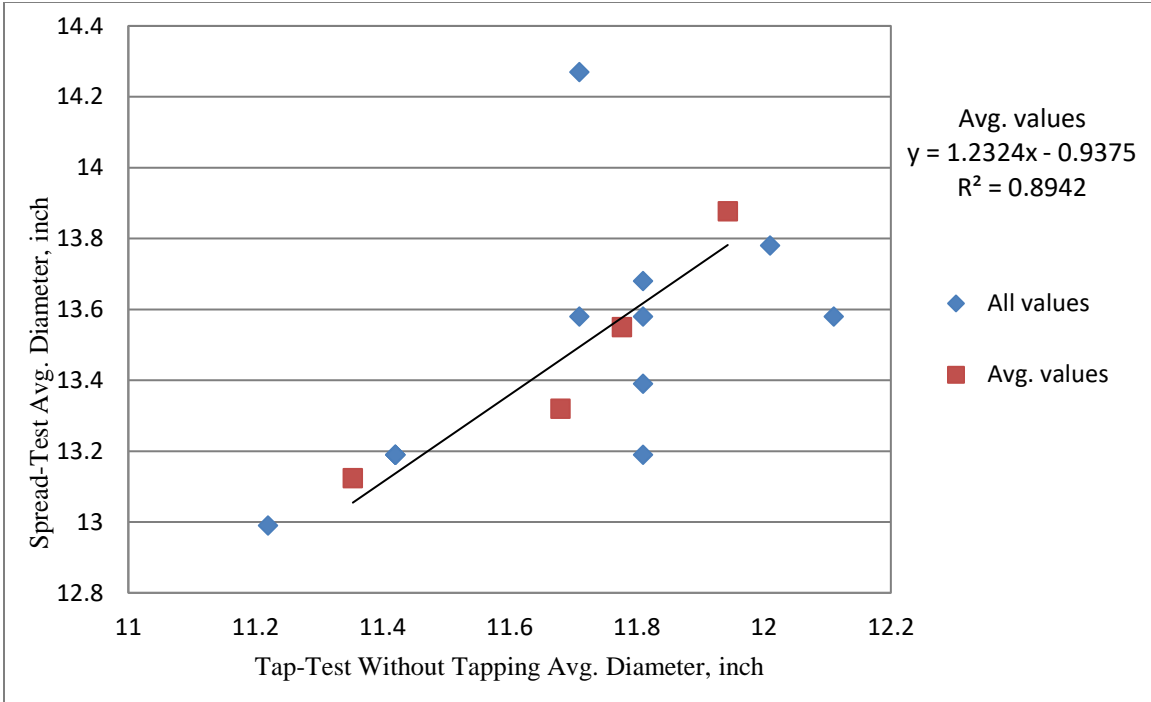

Figure B-19: Correlation between Tap-Test without Tapping and Spread-Test for w/c = 0.43, for Grout Placement in the Wet

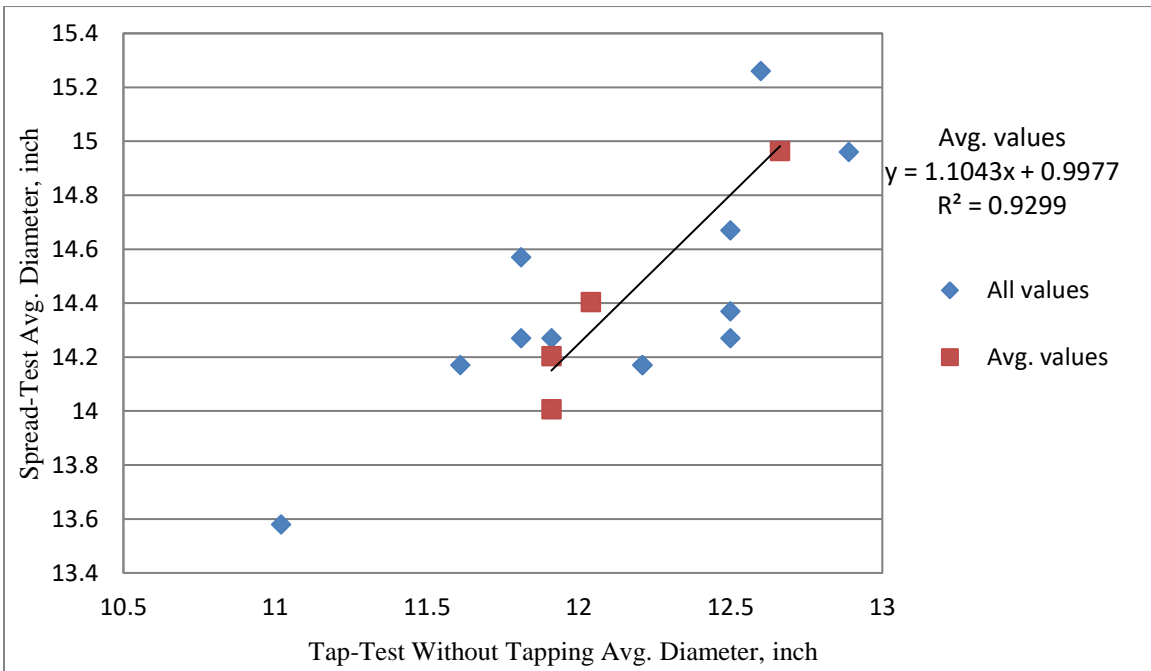

Figure B-20: Correlation between Tap-Test without Tapping and Spread-Test for w/c = 0.45, for Grout Placement in the Wet

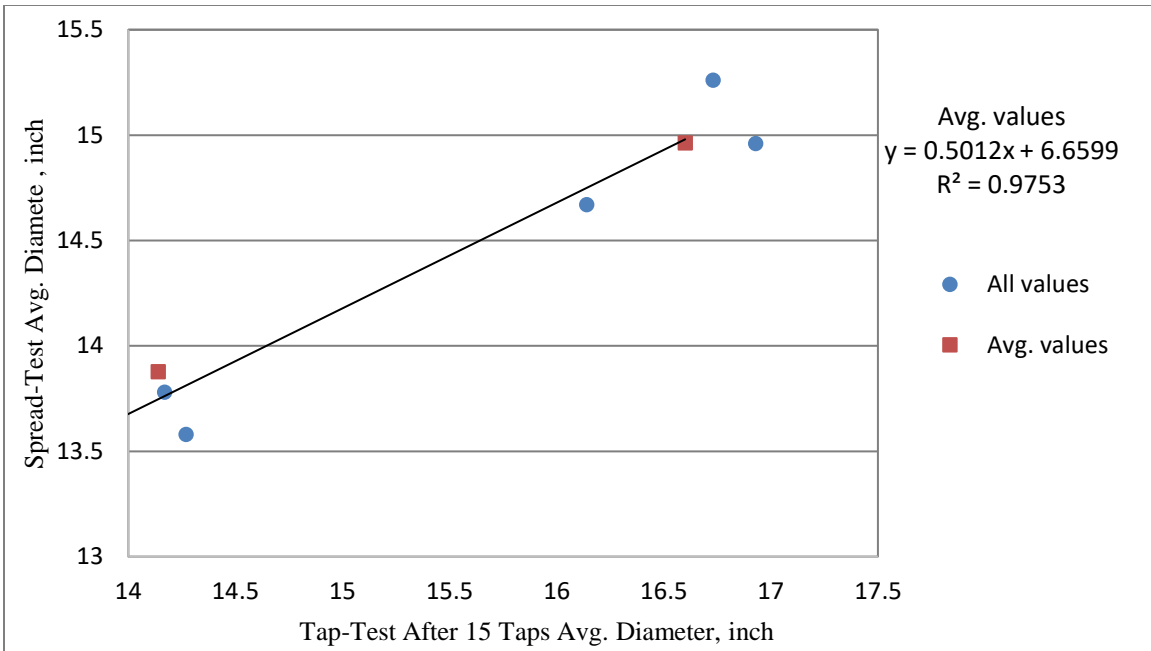

Figure B-21: Correlation between Tap-Test after 15 taps and Spread-Test for AWA = 13 oz /100 lb of cement

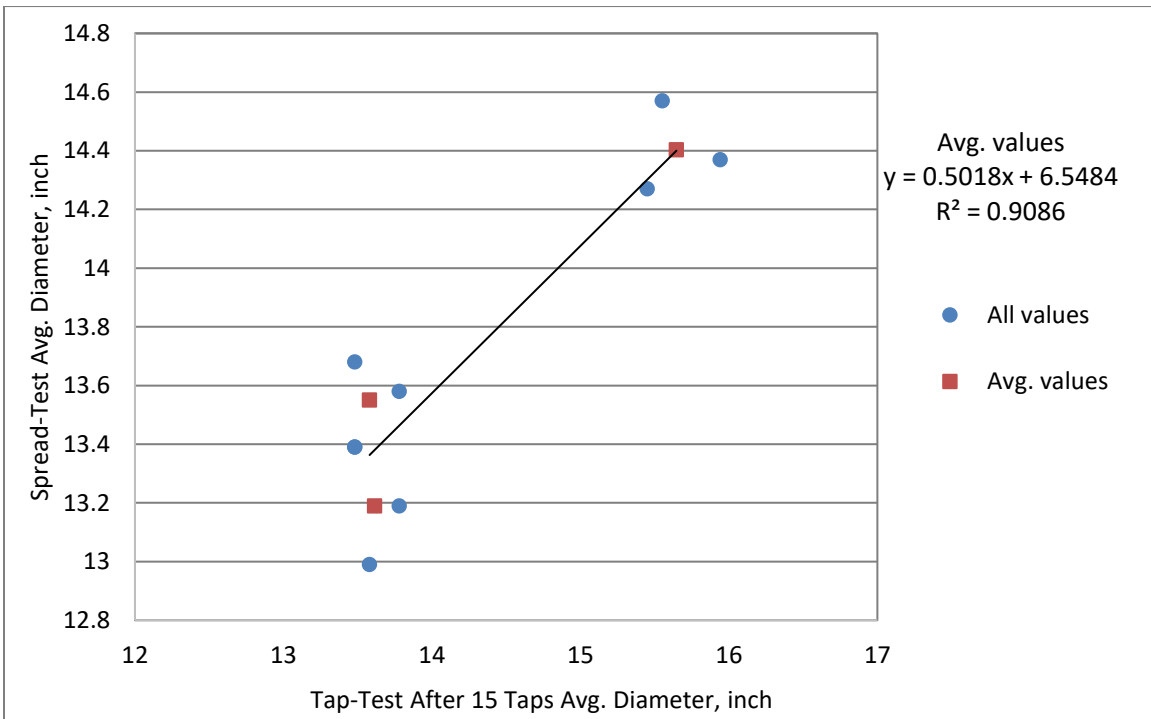

Figure B-22: Correlation between Tap-Test after 15 taps and Spread-Test for AWA = 15 oz /100 lb of cement

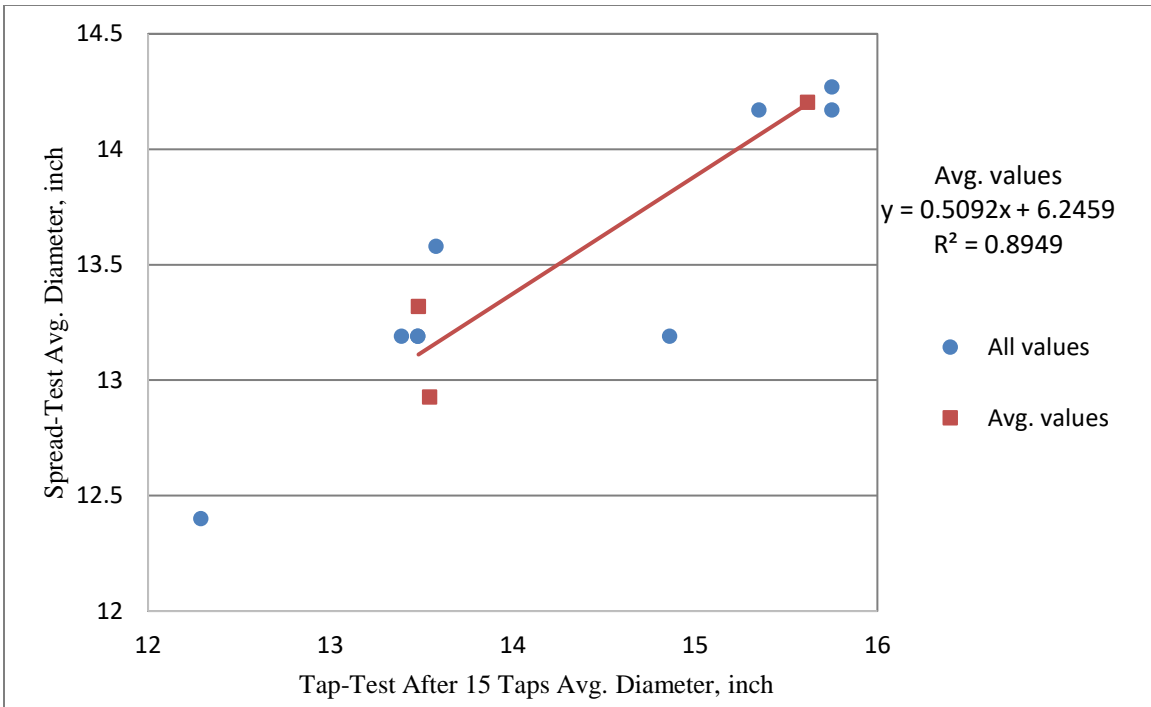

Figure B-23: Correlation between Tap-Test after 15 taps and Spread-Test for AWA = 17 oz /100 lb of cement

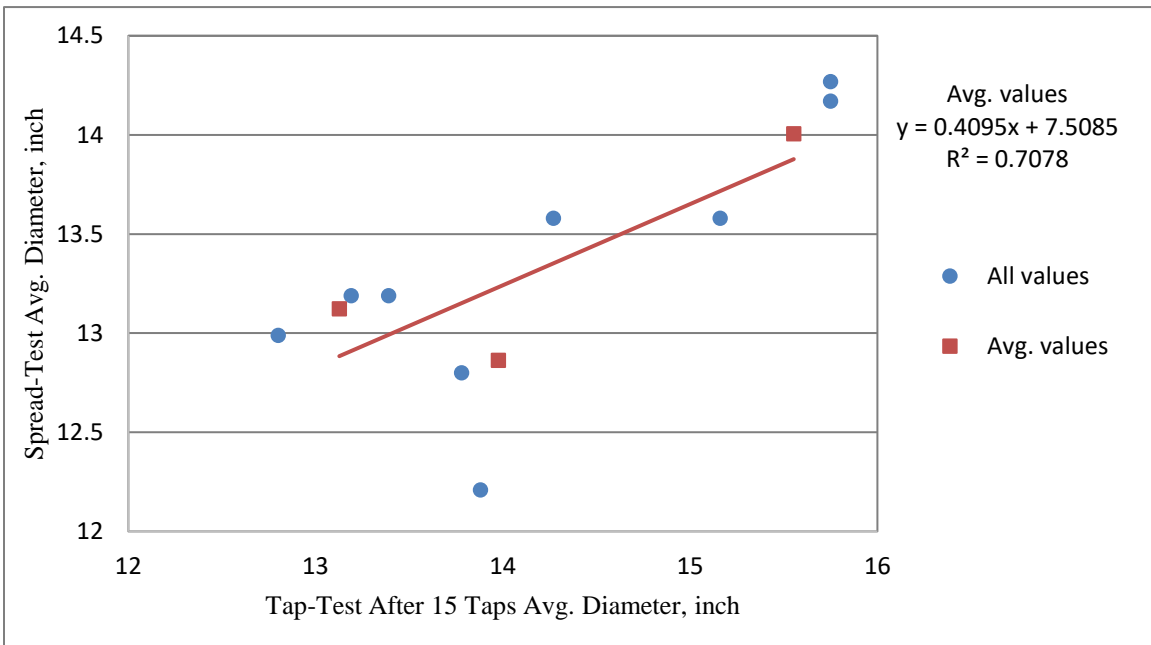

Figure B-24: Correlation between Tap-Test after 15 taps and Spread-Test for AWA = 19 oz /100 lb of cement

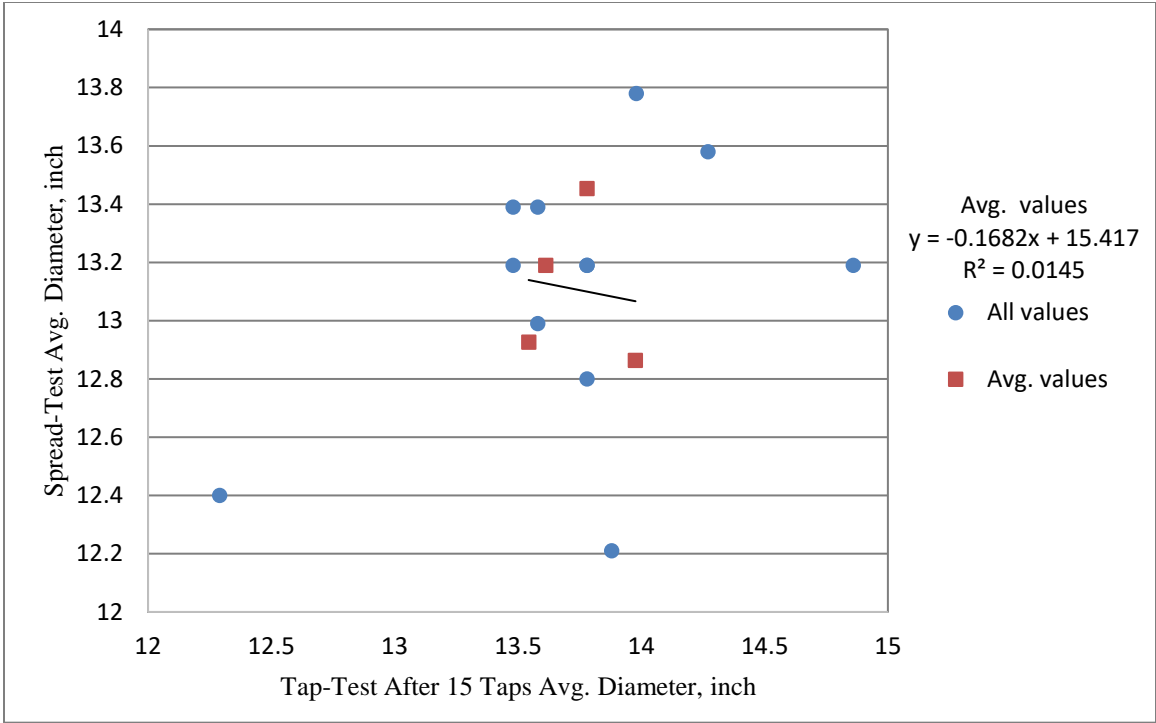

Figure B-25: Correlation between Tap-Test After 15 taps and Spread-Test for w/c = 0.40, for Grout Placement in the Wet

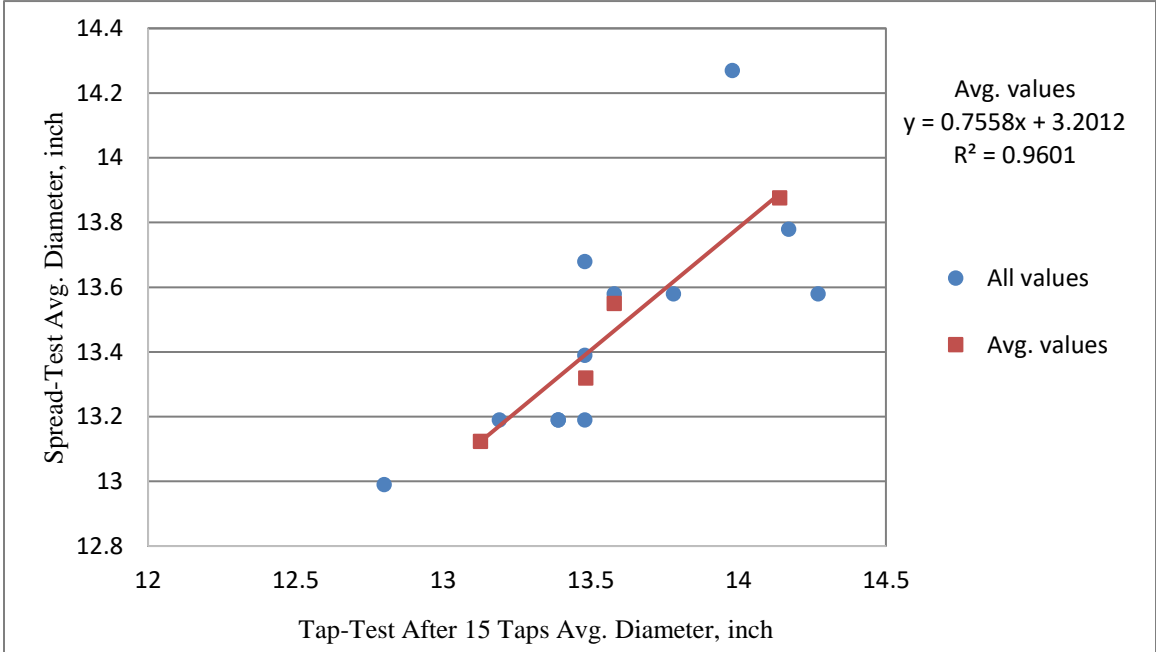

Figure B-26: Correlation between Tap-Test After 15 taps and Spread-Test for w/c = 0.43, for Grout Placement in the Wet



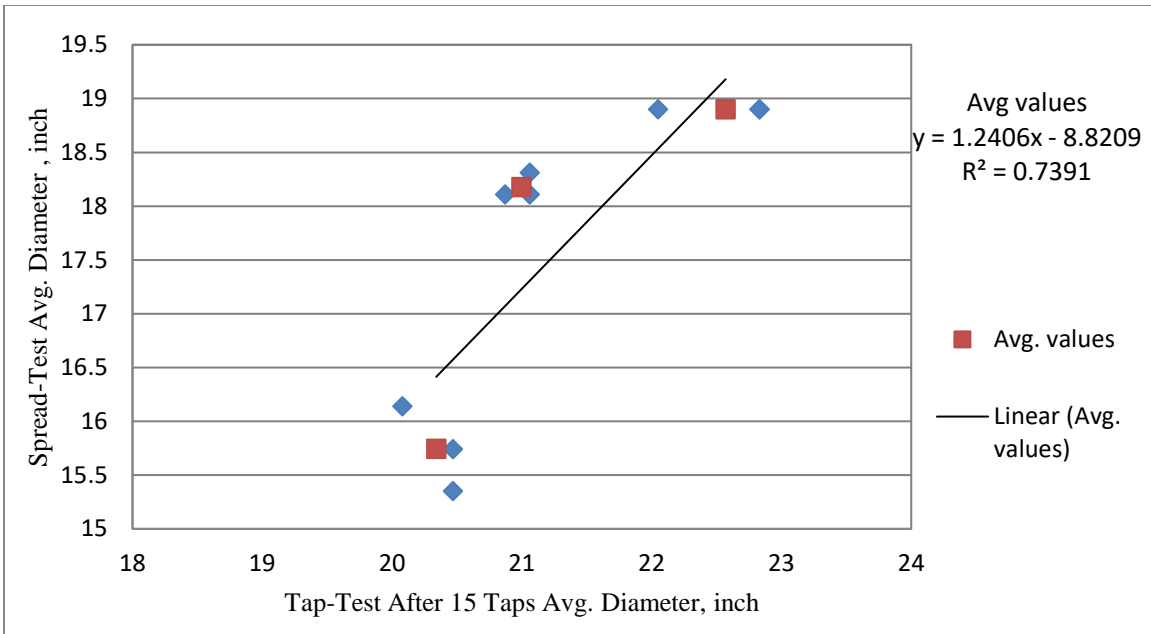

Figure B-29: Correlation between Spread-Test and Tap-Test after 15 Taps for Grout Placement in the Dry

## APPENDIX C “HYDROLOGIC AND HYDRAULIC (H&H) ANALYSIS AND SUMMARY OF PGR SCOUR COUNTERMEASURE DESIGN PARAMETERS”

---

### 1. Introduction

With the assistance of PennDOT District 6-0 Technical Advisor, an existing scour critical bridge BMS # 46202800200000 – Montgomery County, Bridge SR 2028 (Camp Hill Road) over Sandy Run was selected to have partially grouted riprap (PGR) as a scour countermeasure to protect the structure from scour. When the available information for the selected bridge was reviewed, it was determined that a hydrologic and hydraulic (H&H) analysis would be required for the selected bridge to determine the scour countermeasure design parameters. Appendices of Appendix C

The H&H analysis is necessary to document the hydraulic and scour conditions of the existing structure and to identify the applicable countermeasure design criteria. The H&H analysis for Bridge SR 2028 was conducted by Temple/CHA in accordance with the design criteria provided in the Pennsylvania Department of Transportation’s (PennDOT’s) Publication 13M, Design Manual, Part 2, Highway Design, Chapter 10 (DM-2).

The primary objective of Task 3 is to determine the design parameters needed to design the scour countermeasure using PGR. H&H analysis was performed to determine the flow velocity and peak discharge at the crossing of Bridge SR 2028 and Sandy Run during various peak discharges. The information is then used to determine the impact of recurring floods on the bridge foundation and substructure, and to estimate the type and effects of scour at the bridge piers, bridge abutments and stream bed/banks so that the structural integrity of the bridge can be maintained. Further, obtained variables from H&H analysis are utilized to evaluate the potential impacts to Sandy Run following the installation of a structural countermeasure along the bridge abutments and pier, and to set the final countermeasure design during subsequent tasks as part of the research project

### 2. Bridge and Site Description

The Bridge SR 2028 (Camp Hill Road) crossing of Sandy Run is located in the Whitemarsh Township, Montgomery County, Pennsylvania. The structure is located on the U.S. Geological Survey (USGS) quadrangle map entitled Ambler, PA, at 40o07’34.73” N latitude and 75o12’14.09”

W longitude in southeastern Montgomery County. The project location is approximately 2.1 miles southeast of Ambler, PA and is shown in Figure 1 of Appendix A. The bridge consists of a two-span concrete encased rolled steel I-beam structure. The bridge has a scour critical designation (113 = 3) and it was originally constructed in 1931.

The proposed project is determined not cause a significant reduction in the existing waterway opening, or significant change to the grades of approach roadways, or significant change to the overtopping characteristics, or significant change of the alignment and most importantly, the existing structure will not be modified. Thus, an abbreviated H&H Report format was utilized as outlined in DM-2.

All elevation data is referenced to the North American Vertical Datum of 1988 (NAVD88), unless otherwise noted (NAVD88=NGVD29-0.99 feet) and all references are left to right looking downstream.

The drainage area for the bridge was delineated using the USGS StreamStats application and verified by using the most recent USGS quadrangle mapping of the watershed. The drainage area was determined to be 5.48 square miles (sq-mi) and is generally oriented east west. The contributing watershed for Bridge SR 2028 is displayed in Figure 2 of Appendix A. According to the USGS, Sandy Run is an un-gaged stream. USGS Gage 01473900 is located on Wissahickon Creek approximately 2.1 miles downstream of Bridge SR 2028. Although the structure is relatively close to the USGS Gage, the drainage area at the gage is nearly 8 times larger than Bridge SR 2028. Therefore, the gage is not representative of the studied reach and the WRC Hydrologic Methodology cannot be applied.

Sandy Run has been studied by detailed methods in the vicinity of Bridge SR 2028 crossing as part of the Federal Emergency Management Agency (FEMA) Flood Insurance Study (FIS) for Montgomery County. The 2001 Montgomery County FIS is the effective FIS for Sandy Run. However, FEMA is currently in the process of updating the countywide analysis, which has only been released as the Revised Preliminary FIS dated April 2014. The limits of the floodplain and floodway from the effective 2001 FIS are shown on the Flood Insurance Rate Map (FIRM) and the National Flood Hazard Layer (HFHL) in ArcView. The effective 2001 and preliminary 2014, FIS reports can be found in Appendix D and the 100-yr and 500-yr floodplains are shown in [Appendix A](#), Figure 4.

In addition to the FEMA FIS, Act 167 Plans are developed to determine peak rate controls for stormwater management, to assess the hydrologic impact of potential land use changes, to obtain flows at obstructions, and to evaluate the potential impacts of stormwater improvements. The Wissahickon Creek Watershed Act 167 Plan was revised in 2014, but it has not been accepted by the PADEP.

The study reach extends along Sandy Run between the Railroad located upstream of Walnut Ave. and the confluence with Wissahickon Creek. There are 10 bridges/culverts located within the study reach; however, four structures cross Sandy Run in the vicinity of Bridge SR 2028:

- Fort Washington Expressway (Route 309) crosses Sandy Run approximately 250 ft. upstream of the Bridge SR 2028 crossing. The crossing provides multiple openings (culvert and Bridge SR 2028) to discharge flows.

- An old Private Drive Bridge crosses Sandy Run approximately 500 ft. downstream of the Bridge SR 2028 crossing. The structure was observed to be in poor condition (not in use) and was not included in this analysis. This structure does not significantly impact the water surface elevation during large events, and it was not included in the recent FIS revision. Similarly, Temple/CHA has also excluded this structure from the hydraulic analysis based on the structural condition observed during the recent site visit.

- A “High” Railroad Bridge crosses Sandy Run approximately 1,300 ft. downstream of the Bridge SR 2028 crossing. The structure is well elevated and does not significantly impact the water surface elevation at the Bridge SR 2028.

- A “Low” Railroad Bridge crosses Sandy Run approximately 1,500 ft. downstream of the Bridge SR 2028 crossing. According the effective FIS, the structure controls the water surface elevation at the Bridge SR 2028.

The location of the additional structures located within the vicinity of Bridge SR 2028 can be found in Figure 3 of Appendix A. Additional information on the recent site visit can be found in the “site visit” field forms, photo log and location reference map are provided in Appendix B.

### 2.3 Environmental Consideration

In June of 2014, a wetland scientist from Temple/CHA conducted a site visit to determine if wetlands are located in the vicinity of the Bridge SR 2028 crossing of Sandy Run. The assessment concluded that there were no wetlands located within the vicinity of the project site and that the waters of the United States were contained to the channel at Ordinary High Water (OHW). However, it should be noted that a Wetland and Stream (Riparian) Protection Area is located approximately 500 feet downstream of the subject bridge. A complete environmental summary will be included during the final countermeasure design.

Based on a review of the Chapter 93 of the Pennsylvania Department of Environmental Protection (PADEP) Title 25 regulations, Sandy Run is located within Drainage List E for the Delaware River Basin. Therefore, Temple/CHA reviewed Section 93.9e of the PADEP regulations and found that Sandy Run was not listed. Since Sandy Run was not listed in the PADEP regulations, it is assumed that the study reach does not have any specific designated water uses and/or water quality criteria. The supporting documents can be found in Appendix D.

In addition to the water use and water quality criteria, Sandy Run was not listed by the Pennsylvania Fish and Boat Commission (PFBC) as an approved trout waters nor is it found on

either the Stream Sections that Support Natural Reproduction of Trout or the Pennsylvania Wilderness Trout Waters lists. The supporting documents can be found in Appendix D.

## 2.4 Stream Characteristics

A site investigation was conducted in July of 2014 in order to determine flow characteristics, channel geometry and roughness coefficients for the main channel and overbanks. Sandy Run discharges through the Route 309 culvert and the main channel bends approximately 90 degrees (to the right) immediately upstream of Bridge SR 2028. The abrupt change in the direction of the main channel can be observed in Figure 3 of Appendix A, and it is likely contributing to the scouring observed in Span 1 and at the upstream end of the left abutment. In the vicinity of Bridge SR 2028, the channel width varies from approximately 30 to 40 ft. and is contained within steep embankments, which were nearly vertical in some locations. The channel embankment height varied from 3 to 5 feet upstream of the bridge and from 3 to 15 ft. downstream of the bridge. Based on field observations and aerial photos, the channel overbanks in the vicinity of the bridge were generally well vegetated, with interspersed residential and commercial buildings. The ground cover in the upstream right overbank (Route 309) was observed to be primarily perennial vegetation, while the upstream left overbank was primarily open space with some wooded areas. Downstream of the bridge, the left embankment is slightly elevated, and the ground cover is primarily wooded areas adjacent to the channel with buildings and parking areas. The downstream right embankment is wooded (limited underbrush) and is much lower than the left embankment.

Sandy Run typically flows from east to west upstream of the Fort Washington Expressway (Route 309) and its watershed is highly developed (approximately 80%), with limited areas of forest and open space. The terrain within the watershed is characterized by gently rolling hills; with elevations ranging from approximately 350 feet (ft.) in the northeastern most part of the watershed (Camp Hill) to approximately 155 ft. at the bridge. Immediately upstream of the Bridge SR 2028 the stream turns and flows in a northerly direction for approximately 0.5 miles before returning to a westerly path and entering the Wissahickon Creek approximately 1.5 miles downstream of the Bridge SR 2028.

During the recent site visit the primary (>50%) streambed material was observed to be medium sand that was similar both upstream and downstream of the bridge with some gravel and limited presence of fines. An area of clay was observed in span 2 along the right abutment. However, the extent of the deposit at the structure could not be field verified. For more details, the completed "Riverbed Field Soil Classification" form is included in Appendix C

## 2.5 Review of Inspection Reports

According to the information received from PennDOT District 6-0, the Bridge SR 2028 over Sandy Run was last inspected in November of 2012. During the regular 2012 inspection, several priority maintenance requests were recommended. The recent recommendations and their respective priorities include:

- Improve the approach Guiderail to meet current standards (Priority 2)
- Install rock protection along the near abutment, pier and upstream channel (Priority 2)
- Backfill the scour hole under span 1 (Priority 2)
- Improve the bridge railing to meet current standards (Priority 3)
- Repair the far abutment (Priority 3)
- Improve the off-bridge drainage (Priority 3)
- Remove Sediment deposits under span 2 and upstream (Priority 3)
- Remove debris in the channel (Priority 3)
- Repair the deteriorated concrete sidewalks (Priority 3)
- Repair concrete curb and parapet (Priority 3)
- Repair the concrete diaphragms (Priority 3)

During the 2012 Inspection, the channel condition was rated a 4 due to the poor alignment during low flow and associated scour at the upstream left abutment wingwall, the deposition of sediment in Span 2 and the exposed footings at the pier and left abutment. The substructure summary made note that the left abutment footing was exposed the full length with a maximum vertical exposure of 1.5 ft. from the upstream corner to mid-abutment face. Similarly, the concrete footing of the pier was noted to be exposed the full length with a maximum exposure of 2.7 ft near the nose. According to the 1930 bridge plans, the remaining embedment following the 2012 inspection was determined to be 2.5 ft. and 1.3 ft. at the left abutment and pier, respectively. Additionally, the cross-section data at the bridge indicates that the channel is vertically unstable with a decrease in streambed elevation both upstream and downstream of the bridge from 2002 through 2012.

Generally, the regular inspections are conducted every 2-years and special flood inspections are performed as necessary. Following Tropical Storm Irene (TS Irene) in August of 2011, a special flood inspection was conducted on September 2, 2011. However, the cross section data taken after TS Irene only shows minor variation in the streambed when compared to the 2010 inspection data.

## 2.6 Site Observations

During the July 2014 site visit, the scour issues previously documented at the upstream left abutment wingwall end and Span 1 were confirmed. The total scour depth observed in Span 1 was estimated to be approximately 2-3 ft. while Span 2 contained organic material and sand deposits. As described above, the low (3 to 5 ft.) and nearly vertical embankments indicate that the stream is horizontally unstable. Since the upstream channel bends sharply after exiting the Route 309 culvert, the channel has the potential to migrate towards the left abutment at the Bridge SR 2028. In addition, due to the poor channel alignment and significant woody vegetation observed within the study reach, the bridge exhibits a high potential for blockage due to debris.

It appears that following the 2012 Inspection, angular stone (D50=12-15 inches) was placed along the full length of the previously exposed concrete spread footings at the left abutment and left side of the pier. During the 2014 site visit, Temple/CHA observed the top of footing to be partially exposed along the left pier face with a maximum vertical exposure of 0.5 ft. The top of concrete footing at the left abutment was covered by a single layer (~1.0 ft.) of angular stone. The scattered angular stone was observed to be in fair condition; however, the rock extended roughly 5.0 ft. from the left abutment and left pier face. Additionally, the stone was observed to be unstable (moves under foot) likely due to being mounded and placed at a steep slope (4H:3V).

Lastly, during low flow conditions the main channel was observed to be poorly aligned with the bridge and pier. When the discharges from Sandy Run expand into the overbanks during larger flood events the poor alignment of flow to the bridge is minimized. As indicated in the FIS, overtopping relief occurs at the bridge and right roadway approach between the 10-year (yr) and 50-yr flood events.

The site sketch, channel profile, substructure profile, and H&H site assessment forms from the July 2014 field visit can be found in Appendix C.

## 3. Design Criteria

According to the Montgomery County FIS, Sandy Run is studied by detailed methods. The effective Flood Insurance Rate Map (FIRM) shows that the Bridge SR 2028 is located within the regulated floodway. The addition of a countermeasure is considered to be an addition of fill to the regulated floodway. Therefore, an H&H analysis needs to be completed to show that the proposed countermeasure design will maintain and/or reduce water surface elevations during the regulated (100-yr) flood event. Additionally, Bridge SR 2028 is classified as an Urban Collector; therefore, the PennDOT District 6-0 design (25-yr) flood will be assessed for any increases in water surface elevation.

Chapter 10.7.D.2 states that when a proposed project is located in a FEMA detailed study area, peak flow values are different from the FEMA FIS and the project does not cause an increase to the 100-yr WSE, the following topics should be discussed in the H&H Report.

- Calculate Hydrology with PennDOT District 6-0 accepted methods
- Model the 25-yr, 50-yr, 100- and 500-yr events
- Compare the existing model water surface elevation to the published regulatory base flood elevations

In order to satisfy the Pennsylvania General Permit (GP-11) and meet the requirements set forth DM-2, Temple/CHA has provided a detailed explanation of the H&H analysis.

#### 4. Hydrologic Analysis

Sandy Run was studied by detailed methods as part of the effective 2001 Montgomery County FIS. According to the FIS report, the hydrologic analysis for Sandy Run in the Whitemarsh Township was completed by the U.S. Army Corps of Engineers (USACE) for the 1992 FIS. The PSU-IV regional method was used to estimate the peak discharges for Sandy Run. Regional equations utilized the drainage area size, location within the State, and divide elevation at the 153ylvania site to develop peak discharges for the studied reach. The hydrologic analysis was completed in August of 1990. The discharges developed for the 1992 FIS were not revised as part of the 2001 countywide revision. Applicable sections of the effective 2001 Montgomery County FIS are included in Appendix E.

Although FEMA provides discharges for Bridge SR 2028 at the crossing of Sandy Run, the PSU-IV methodology is not considered to be an acceptable hydrologic method according to DM-2 and can only be used for comparison purposes. As mentioned above, FEMA is currently in the process of revising the effective 2001 FIS and a Preliminary Revised FIS report was published in April 2014. As part of this revision, the Sandy Run hydrology was restudied utilizing a calibrated HEC-HMS model for Wissahickon Creek. Sandy Run is a tributary to Wissahickon Creek and the confluence is located approximately 1.5 miles downstream of the Bridge SR 2028. According to DM-2, design discharges developed from a HEC-HMS model are an acceptable methodology. The hydrologic analysis was conducted by Temple University and the work was finalized in 2010. Applicable sections of the Preliminary Revised 2014 Montgomery County FIS are included in Appendix E.

Additionally, the USGS StreamStats website (<http://water.usgs.gov/osw/streamstats/penn153ylvania.html>) was used to predict peak flows for comparative purposes and to verify drainage basin characteristics of Bridge SR 2028. The USGS StreamStats website is a GIS based interactive user interface that is based on the regression equations presented in SIR 5102. The delineated watershed was manually edited near Bridge SR 2028 based on the USGS quadrangle map. A summary of the StreamStats analysis can be found in Appendix E.

A comparison of the peak discharges developed from the methodologies described above are presented in Table 1.

Table 1 – Sandy Run Peak Discharge Summary

<b>Hydrologic Method</b>	<b>2-Yr Flood (cfs)</b>	<b>10-Yr Flood (cfs)</b>	<b>25-Yr Flood (cfs)</b>	<b>50-Yr Flood (cfs)</b>	<b>100- Yr Flood (cfs)</b>	<b>500- Yr Flood (cfs)</b>
USGS StreamStats	726	1,270	-	1,830	2,090	2,760
2001 Effective FIS (PSU-IV)	-	2,690	-	4,045	4,865	6,500
<b>2014 Preliminary FIS (HEC-HMS)</b>	<b>763<sup>1</sup></b>	<b>2,229</b>	<b>3,010<sup>1</sup></b>	<b>3,931</b>	<b>4,945</b>	<b>8,165</b>

<sup>1</sup> Value interpolated using the probability log cycle graph.

The discharges developed using the HEC-HMS model were found to be similar to those developed by the PSU-IV methodology. Bridge SR 2028 is located approximately 0.5 miles upstream of the confluence with Pine Run. The discharges presented above were taken from the FIS discharge tables above the Pine Run confluence. As such, the design flows provided in the Revised Preliminary 2014 FIS (HEC-HMS) represent the best available hydrologic study for Sandy Run and were utilized for the hydraulic analysis.

## 5. Hydraulic Analysis

The hydraulic analysis was performed using the U.S. Army Corps of Engineers' River Analysis System (HEC-RAS), Version 4.1.0. Sandy Run was modeled using subcritical flow scenarios for the 2-, 10-, 25-, 50-, 100-, and 500-yr recurrence intervals. Additionally, an incipient overtopping run was modeled which has a recurrence interval between the 10-yr and 25-yr flood event. The detailed output from the hydraulic model can be found in Appendix F, while the locations of the modeled cross-sections are shown in Figure 5 of Appendix A.

### 5.3 Methodology

As recommended in DM-2, Chapter 10, the hydraulic model was utilized to evaluate the water surface profiles, flow and velocity distributions, flood risk, and the reaction of the stream to the installation of the proposed countermeasures. As discussed above, Sandy Run was studied by detailed methods as part of the effective 2001 Montgomery Countywide FIS and the preliminary

revised 2014 Montgomery Countywide FIS. The Bridge SR 2028 is located within the limits of an existing floodway according to the Flood Insurance Rate Map (FIRM) and the National Flood Hazard Layer (NFHL). Therefore, Temple/CHA obtained the backup data for both the effective 2001 FIS, which was developed in HEC-2, and the HEC-RAS backup data for the revised preliminary 2014 FIS from the FEMA. A copy of the HEC-2 input and output files from the effective 2001 FIS were obtained but not utilized in the analysis.

The hydraulic results presented in this report are based on the assumption of unobstructed flow through the bridge section. The flood elevations established by the HEC-RAS model are thus considered valid if the hydraulic cross-section of the bridge remains clear of debris.

#### 5.4 FEMA Model Discussion

At this time, the revised preliminary 2014 FIS is not the effective FEMA FIS for Sandy Run. However, for the purposes of this analysis, information presented in the revised preliminary 2014 FIS report and the backup HEC-RAS model will be utilized to the greatest extent possible, as it represents the best available hydraulic data for the study reach.

According to the revised preliminary 2014 FIS report, the hydraulic analysis was updated by Temple University under a FEMA contract that was finalized in 2010. According to the 2014 FIS report, the cross section geometry was developed from a TIN generated from the 2006 LIDAR using the GeoRAS extension for ArcView. Station elevation data at cross sections were supplemented with field measurements and aerial surveys as necessary and all structures (bridges, dams, and culverts) were field surveyed.

Once the HEC-RAS model was obtained from FEMA, Temple/CHA truncated the model to include a 2.2-mile long reach in the vicinity of Bridge SR 2028. The truncated model begins at cross section 11764 that represents the approach section for the railroad bridge near Walnut Ave and extends downstream approximately 2.2 miles to the confluence with Wissahickon Creek. The truncated model includes the FEMA lettered cross sections A through G. The downstream boundary used in the FEMA model was maintained in the truncated model to match the water surface elevations presented in the revised preliminary 2014 FIS report. It is important to note that the cross section location and lettering was updated in the 2014 FIS revision. An overview of the FEMA cross section locations are displayed in Appendix A, Figure 5.

#### 5.5 Updates to Effective FEMA Model

The elevation data of the preliminary FIS HEC-RAS model was supplemented with field survey (July 2014) in the vicinity of the Bridge SR 2028 crossing. In addition to refining the channel and overbank areas, the survey was utilized to verify and update the bridge opening, as well as to

quantify any changes along Sandy Run that may have occurred since the model was developed in 2010.

During the 2014 site visit Temple/CHA confirmed the hydraulic opening of the two downstream railroad crossings. A review of the hydraulic openings in the field indicated that the openings provided in the HEC-RAS were oversized. Therefore, the existing condition model included updates to the “High” railroad crossing (XS 6765) and the “Low” railroad crossing (XS 6600). Although the crossings are located 1300 ft. and 1500 ft. downstream of bridge SR 2028, the “Low” railroad crossing dramatically impacts the water surface elevations through the studied reach.

In order to accurately represent the expansion and contraction of Sandy Run in the vicinity of the Bridge SR 2028, cross sections 8184, 8140, 8104, 7882, 7801, 7724 and 7663 were added to better represent the local hydraulics. In addition, FEMA cross sections 8235, 8063, 7966 and 7570 were updated with survey data. Excluding the two downstream railroad bridges explained above, no changes were made beyond cross sections 7570 and 8235. The additional cross-sections were developed from a LIDAR DEM obtained from the PA Geospatial Data Clearinghouse using the GeoRAS extension for ArcView. Station elevation data at cross-sections were supplemented with field measurements and survey data, as necessary. The locations of the additional cross-sections are shown in Figure 6 of Appendix A.

The roughness coefficients (Manning’s “n”) and the contraction and expansion coefficients for each cross-section were based on the HEC-RAS model and verified during the recent site visit. The value utilized for the channel was 0.03 through the study reach while the overbanks ranged from 0.02 to 0.10. As described above, the channel, embankments and overbank vegetation varied, with the majority of vegetation and roots beginning at the bottom of the bank. The location of the modeled cross-sections and site photographs (main channel and floodplain) can be found in Appendix A and Appendix B, respectively.

The survey extended along both roadway approaches and followed the channel and overbank area of Sandy Run for approximately 500 ft. downstream and 200 ft. upstream. The Route 309 culvert is located approximately 200 ft. upstream and serves as the upstream terminus of the field survey. The source of the station elevation data used in the existing conditions model is shown in Figure 7 of Appendix A.

According to subparagraph 65.6(a)(2) of the NFIP Regulations, the existing HEC-RAS model must tie in to the effective (2014 HEC-RAS Model) water-surface profile within 0.5 foot at the downstream and upstream ends of the revised section of the reach. As shown in

Table 1, the existing condition model meets the NFIP Regulations. A comparison of the 100-year water surface elevation between the effective FEMA model and the existing condition is provided in Appendix F. In general, changes to the 100-yr WSE were observed from XS 6572 to XS 11405 with increases from the effective WSE ranging from 0.0 – 1.9 ft.

Table 1 - Hydraulic Model Comparison

Hydraulic Model Station	Base Flood (100-yr) WSE (ft. NAVD88)		
	FEMA HEC-RAS Model	Existing HEC-RAS Model	$\Delta$ (ft.)
Cross Section 5508 (Lettered FEMA XS B)	169.6	169.6	0.0
Cross Section 11764 (Lettered FEMA XS G)	180.5	180.5	0.0

#### 5.4 Existing Condition Model

The existing structure is a two-span concrete encased rolled steel I-beam bridge with wingwalls that extend parallel to the abutments downstream and at the upstream left abutment. There is no wingwall at the upstream right abutment. The structure has width of 36.0 ft. (out-to-out) and carries two traveled lanes and two pedestrian sidewalks. The normal clear (perpendicular distance to the abutment face) is 16.0 ft. for each span. The pier was observed to have a rounded nose and the width and length were confirmed to be 2.5 ft. and 50.0 ft. respectively. Although the structure is skewed approximately 50 degrees to the roadway, it is still not aligned during low flow, resulting in a 5-10 degree angle of attack at the pier and left abutment. Blocked obstructions were added in the vicinity of Bridge SR 2028 and represent a commercial building located in the downstream left overbank.

Internal cross sections were utilized at Bridge SR 2028 to represent the current streambed within the bridge section. The abutments, low chord elevations, high chord elevations and top of parapets (barriers) were developed from the 2014 survey data. It should be noted that the parapet was observed to extend beyond the bridge section at the upstream right approach. For the purposes of this analysis, the bridge deck weir coefficient was maintained at 2.8 and the 'Energy' method was selected as the high flow computational method. The upstream energy grade line was also selected as the pressure flow criteria for Bridge SR 2028 due to extensive overtopping and to remain consistent with FEMA.

The existing condition hydraulic model indicates that the current bridge is hydraulic deficient with incipient overtopping occurring between the 10- and 25-year storm events. In addition, the 50-yr and 100-yr events result in 2.6 ft. and 4.4 ft. of water overtopping the low point in the roadway, respectively. A summary of the existing condition hydraulic analysis results is presented in

Table 2 and detailed computations are included in Appendix F.

Table 2 – Existing Hydraulic Data

Design Parameters	Design Flood	DEP Guidance	Regulated Flood	Check Flood
Recurrence Interval (yr)	25	50	100	500
Peak Discharge (ft <sup>3</sup> /sec)	3,010	3,931	4,945	8,165
Water Surface Elevation (STA 8063)	172.0	174.0	175.9	178.6
Freeboard (ft.) <sup>1</sup>	-3.5	-5.5	-7.4	-10.1
Velocity Through Structure (ft/sec) <sup>2</sup>	8.1	2.5	2.2	1.5

<sup>1</sup> Negative freeboard indicates distance above the low chord elevation (pressure flow/overtopping condition) at the upstream fascia.

<sup>2</sup> Bridge velocities were referenced from the detailed bridge output

A list of the errors and warnings were reviewed for the existing hydraulic model. It was determined that the warning messages did not impact the model output and as a result no further action was taken.

#### 5.6 Ordinary High Water Elevation

As described above, Sandy Run was observed to be a low gradient stream with the main channel width ranging from 30 to 40 ft. in the vicinity of the Bridge SR 2028. The low (3 to 5 ft.) and nearly vertical embankments provide easy access to the floodplains during flood events. During the recent 2014 survey, the approximate OHW elevation at the upstream left abutment was identified as approximately 163 ft. It should be noted that although limited evidence of the typical OHW was observed, this elevation is similar to the top of embankment elevation identified immediately upstream of the bridge. In addition, Temple/CHA compared the OHW elevation and the calculated 2-yr WSE at the upstream fascia of the bridge. In general, these elevations were found to be similar and they will be used in the Final Countermeasure Design.

#### 5.7 Proposed Condition Model

The proposed condition does not include any modifications to the existing structure described above. However, the streambed elevation through the bridge and bounding cross-sections were updated to represent the top of the proposed countermeasure. The countermeasure is proposed to re-establish the existing riverbed geometry/elevations, will be installed across the full channel of the bridge and will include a low flow channel in Span 1 to encourage aquatic organism passage.

The countermeasure will be installed flush with the streambed and the deposition of sand and organics within Span 2 will be removed. In general, the proposed project will protect the existing bridge from scour and will improve the hydraulic capacity of the undersized bridge by offering an additional 11.9 sq-ft of hydraulic opening.

The proposed countermeasure design will not adversely impact water surface elevations within the study reach and will maintain discharge velocities through the bridge for each of the flood events investigated. The results of the proposed condition analysis are presented in Table 3 and detailed computations are included in Appendix F.

Table 3 – Proposed Hydraulic Data

Design Parameters	Design Flood	DEP Guidance	Regulated Flood	Check Flood
Recurrence Interval (yr)	25	50	100	500
Peak Discharge (ft <sup>3</sup> /sec)	3,010	3,931	4,945	8,165
Water Surface Elevation (STA 8063)	171.9	174.0	175.9	178.6
Freeboard (ft.) <sup>1</sup>	-3.4	-5.5	-7.4	-10.1
Velocity Through Structure (ft/sec) <sup>2</sup>	8.0	2.4	2.1	1.5

<sup>1</sup> Negative freeboard indicates distance above the low chord elevation (pressure flow condition) at the upstream fascia.

<sup>2</sup> Bridge velocities were referenced from the detailed bridge output.

A list of the errors and warnings were reviewed for the proposed hydraulic model. It was determined that the warning messages did not impact the model output and as a result no further action was taken.

## 5.8 Water Surface Elevation Comparison

As required in DM-2, Chapter 10 and recommended in the QA Checklist, a comparison of both the 25-yr and 100-yr water surface elevations were conducted for the existing and proposed hydraulic models. The comparison of the water surface elevations is shown in **Error! Reference source not found**. And detailed output from the hydraulic model is presented in Appendix F

Table 4 - Water Surface Comparison

HEC-RAS Model Station	25-yr WSE (ft. NAVD88)			100-yr WSE (ft. NAVD88)		
	Existing	Proposed	Δ (ft.)	Existing	Proposed	Δ (ft.)
5508	166.4	166.4	0.0	169.6	169.6	0.0
6189	166.4	166.4	0.0	169.3	169.3	0.0
6415	168.2	168.2	0.0	172.6	172.6	0.0
6573	168.2	168.2	0.0	172.9	172.9	0.0
6668	169.6	169.6	0.0	175.0	175.0	0.0
6710	169.6	169.6	0.0	174.8	174.8	0.0
6826	170.1	170.1	0.0	175.6	175.6	0.0
7174	170.4	170.4	0.0	175.8	175.8	0.0
7571	170.4	170.4	0.0	175.7	175.7	0.0
7663	170.4	170.4	0.0	175.7	175.7	0.0
7724	170.4	170.4	0.0	175.7	175.7	0.0
7802	170.4	170.4	0.0	175.7	175.7	0.0
7882	170.4	170.4	0.0	175.8	175.8	0.0
7967	170.4	170.4	0.0	175.8	175.8	0.0
8064	172.0	171.9	- 0.1	175.9	175.9	0.0
8104	172.0	171.9	- 0.1	175.9	175.9	0.0
8140	172.0	171.9	- 0.1	175.9	175.9	0.0
8185	172.0	171.9	- 0.1	175.8	175.8	0.0
8236	171.9	171.9	0.0	175.8	175.8	0.0
8505	172.4	172.3	- 0.1	176.2	176.2	0.0
8976	172.5	172.5	0.0	176.4	176.4	0.0
9640	172.6	172.5	- 0.1	176.4	176.4	0.0
9745	174.8	174.8	0.0	176.7	176.7	0.0
10118	174.9	174.8	-0.1	176.7	176.7	0.0
10661	174.9	174.8	-0.1	176.7	176.7	0.0
10734	174.9	174.9	0.0	176.7	176.7	0.0
11303	174.4	174.4	0.0	176.2	176.2	0.0
11405	177.0	177.0	0.0	180.0	180.0	0.0
11764	177.5	177.5	0.0	180.5	180.5	0.0

As shown above, the 25-yr and 100-yr water surface elevations do not increase from the existing to the proposed conditions. Although the proposed bridge includes the addition of fill (stone) to the regulated FEMA floodway, according to DM-2, Chapter 10, Appendix C.1.b an encroachment analysis is not required since the 100-yr water surface elevation does not increase from the existing to proposed condition.

## 5.8 Temporary Condition

The installation of the proposed countermeasure will follow an assumed phased approach that will allow for access to parts of the channel, abutments and pier. This phase approach does not represent the finale design approach. Further, since all work for the proposed project is to be completed near the foundations of the existing structure, Temple/CHA does not anticipate that a detour or temporary bridge will be necessary. An explanation of the assumed phasing is provided in Figure 1. The final installation and construction details for the temporary condition will be developed during the final countermeasure design.

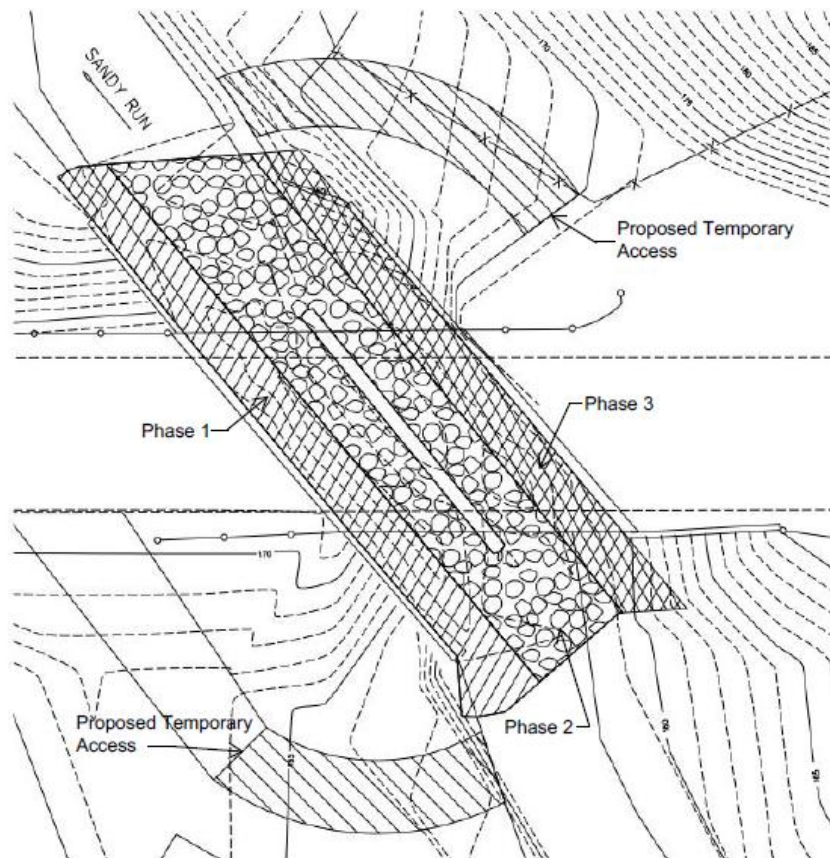

Figure 1 Preliminary Phasing Plan

As explained above, the project objectives are to install the proposed countermeasure at the existing structure while minimizing the impacts to the surrounding areas/resources. In accordance

with DM-2, Temple/CHA developed a temporary condition hydraulic model in HEC-RAS to assess the hydraulics of the 2-yr event during each phase of the countermeasure installation. The results of the hydraulic model during the temporary conditions can be found in Appendix F.

During Phase 1, a temporary flow diversion will be placed upstream of Span 1 and work will focus on the left abutment. The diversion will be used to divert/deflect the majority of flow away from the left abutment and limit the channel velocity observed in work area (left side of Span 1). For the purposes of the hydraulic model, the diversion was assumed to be approximately 8 ft. in length and 3 ft. in height. It is important to note that Span 1 will remain wet during the excavation and the installation of the countermeasure along the left abutment. During the excavation of the channel in Phase 1, the disturbed area will be contained with turbidity curtains. Additionally, a causeway will be constructed from the right bank along the downstream bridge fascia. The causeway will provide access to the left abutment (Span 1) from the downstream right embankment. The causeway will span the majority of the downstream channel and will pass the low flow discharges through culverts. For the purposes of the hydraulic model, the hydraulic capacities of the culverts were not modeled and the height of the causeway will be similar to the diameter of the culverts.

During Phase 2, the temporary flow diversion described in Phase 1 will be relocated upstream of the pier nose. The diversion will be used to divert the majority of flow through Span 1 (preferably along the left abutment) and limit the channel velocity around the left pier face. For the purposes of the hydraulic model, the diversion was assumed to be approximately 8 ft. in length and 3 ft. in height. It is important to note that Span 1 and Span 2 will remain wet during the excavation and the installation of the countermeasure along both faces of the pier. During excavation of the channel in Phase 2, the disturbed area will be contained with turbidity curtains. Additionally, the causeway utilized in Phase 1 (D/S Span 1) will be partially removed to increase the hydraulic capacity of the natural (unconstructed) channel. The modified causeway will still provide the necessary access to both sides of the pier from the downstream right embankment. As explained above, the causeway will pass the low flow discharges through culverts. For the purposes of the temporary condition model, the culverts passing under the causeway were not modeled and the height of the causeway will be similar to the diameter of the culverts. Following the completion of Phase 2, the temporary flow diversion will be removed from the channel.

During Phase 3, a temporary cofferdam will be installed upstream of Span 2. The cofferdam will be constructed approximately 35 ft. upstream of the bridge fascia and will span from the upstream pier nose to the upstream right embankment. The top of the temporary cofferdam will be constructed to an elevation of approximately 163.0 ft. Dry working limits will be established along the right abutment while the majority of low flows will pass through Span 1 (installed countermeasure). The installation of the countermeasure along the right abutment will be performed in the dry. Since the installation of the countermeasure does not include changes to the existing foundation, the temporary cofferdam will be allowed to overtop when dry working limits are not necessary. Additionally, the causeway utilized in Phase 1 and Phase 2 will be partially removed and modified with the temporary cofferdam (downstream of Span 1) to limit the

constriction on channel. Following the completion of Phase 3, the temporary cofferdam and downstream causeway will be completely removed.

Based on the HEC-RAS model of the temporary conditions, the cofferdam, causeway and temporary water diversion were found to increase the existing 2-yr WSE; however the increase is localized and they do not adversely impact adjacent structures in the vicinity of the bridge. A maximum increase in the 2-yr water surface elevation of 0.8 ft. will be observed during Phase 3. During this phase, the water surface elevation increases are limited to the reach between Bridge SR 2028 and Valley Green Road. Additionally, the countermeasure installation (all 3 phases) is anticipated to take 6-8 weeks to complete.

## 6. Scour Assessment

According to Design Manual 4 (DM-4), Chapter 7 indicates that the scour assessment should include the sum of contraction scour, pressure flow scour (vertical contraction scour), if applicable, and local scour, which includes both the pier and abutment scour and the scour from debris on the piers, if applicable. However, the proposed geometry includes the implementation of structural countermeasures to protect the piers and abutments from scour. Temple/CHA developed an assessment of the existing structure to better understand the potential scour susceptibility of the current crossing.

### 6.1 Streambed Soil

The  $D_{50}$  of the streambed soil is based on the average streambed material size in the channel both upstream and downstream of the subject bridge. The  $D_{50}$  is generally characterized by the size of the material that will be transported by the stream, typically within the top 1.0 ft. of the streambed. According to DM 4, Chapter 7, acceptable means to estimate the  $D_{50}$  include visual inspection, the use of field tools (i.e. sand gauge, gravelometer, wire screen etc.), and sieve analysis from volume/bulk samples. Therefore, during the 2014 site visit, the streambed was observed to be composed of sand with some gravel and limited fines. The streambed material was estimated by visual inspection to be medium sand with an estimated  $D_{50}$  of 0.015 inches (0.001 ft.). It should be noted that clay deposits were observed in Span 2 but were negated as part of this analysis. The  $D_{50}$  used in the scour analysis was determined based on visual inspection. However, representative soil samples have been collected and a gradation analysis will be used in the Final Countermeasure Design.

### 6.2 Scour Analysis

The existing bridge was evaluated for its susceptibility to scour in accordance with FHWA Hydraulic Engineering Circular No. 18 (HEC-18) entitled Evaluating Scour at Bridges (Fifth Edition, April 2012) and the guidance provided in DM-4, Chapter 7. The results of the existing hydraulic model indicate that incipient overtopping occurs before the 25-yr flood event. As such, Temple/CHA evaluated the existing structure for the incipient overtopping event as it presents the greatest scour potential. Overtopping relief is provided at the bridge, left and right approaches with discharges from the 25-yr event and greater.

The inspection reports and field observations show negligible degradation has occurred at Bridge SR 2028. However, sediment deposits (aggradation) were observed downstream of span two. There is limited evidence to support the observed/expected degradation depths necessary for the countermeasure design parameters without further analysis. Therefore, Temple/CHA assumed that 0.0 – 0.5 ft of degradation is likely for the scour analysis and countermeasure design parameters. It should be noted that the clay deposits observed along the right abutment likely help limit the expected scour depths.

Contraction scour was evaluated for the existing structure according to the HEC-18 guidelines. As described above, the streambed was observed to have a  $D_{50}$  of approximately 0.015 inches (0.001 ft.). The critical velocity calculations indicate that contraction scour would be live-bed, meaning that the flow has the potential to transport sediment into the bridge opening during the incipient overtopping flood event. In addition, the bridge also experiences pressure flow conditions during this event, and as such, Temple/CHA evaluated the potential for vertical contraction scour. The results of the analysis indicate up to 15.1 ft. of contraction scour during the incipient overtopping event, which is approximately 3.8 ft. more than was predicted with the standard live-bed equation. Details of the contraction scour analysis are included in Appendix G.

Pier scour was evaluated for the existing structure based on the HEC-18 guidelines. The following parameters were used for the pier scour analysis during the incipient overtopping event:

- Velocity (fps);  $V_1 = 11.55$
- Depth (ft);  $Y_1 = 12.36$
- Pier Width (ft);  $a = 2.5$
- Pier Shape Coefficient (Circular);  $K_1 = 1.0$
- Pier Angle Coefficient;  $K_2 = 1.59$
- Bed Condition Coefficient;  $K_3 = 1.1$

As described above, the streambed was observed to have a  $D_{50}$  of approximately 0.015 inches (0.001 ft.). In addition, although there was significant woody vegetation observed within the study reach, PennDOT District 6-0 Inspection Reports have not historically documented debris at the pier, and as such, it was not accounted for in the scour analysis. Utilizing the standard CSU

Equation, Temple/CHA estimated the potential for 12.1 ft. of local pier scour during the incipient overtopping event. Details of the pier scour analysis are included in Appendix G.

Although the calculation of Abutment Scour is not recommended by PennDOT for the H&H analysis, Temple/CHA calculated the Abutment Scour at Bridge SR 2028 utilizing HEC-RAS for the existing structure. The Abutment Scour was calculated for the Incipient Overtopping Event and calculated in HEC-RAS using Froehlich’s equation (Froehlich, 1989). The HEC-RAS scour analysis utilizes methodology outlined in HEC-18 and the scour parameters were updated to match the values listed in the flow distribution table of the approach cross section. The following parameters (left/right) were used from the abutment scour analysis:

- Depth at Toe (ft) = 11.0 / 10.1
- Degree of Skew (degrees) = 130 / 40
- Projected Length (ft);  $L' = 272.3 / 42.6$
- Average Depth Obstructed (ft);  $Y_a = 9.5 / 3.5$
- Flow Obstructed (cfs);  $Q_e = 4,520.0 / 210$
- Flow Area Obstructed (sq ft);  $A_e = 1,434 / 116$

Utilizing the Froehlich Abutment Scour Equation, Temple/CHA calculated the potential for 26.8 ft. and 10.6 ft. of abutment scour during the incipient overtopping event at the left and right abutment, respectively. Details of the abutment scour analysis are included in Appendix G. Based on the calculated scour depths and remaining embedment, Bridge SR 2028 is considered to be a scour critical bridge and structural countermeasures are recommended to protect the pier and both abutments. Table 6 provides a summary of the calculated scour depth and detailed calculations can be found in Appendix G.

Table 5 – Calculated Scour Depths

Substructure Unit	Calculated Scour Depths for the Incipient Overtopping Event (ft)			
	Local	Contraction	Long Term	Total
Left Abutment	26.8	15.1	0.5	42.4
Pier	12.1	15.1	0.5	27.7
Right Abutment	10.6	15.1	0.5	26.2

Considerable scour was calculated at the existing bridge abutments and pier. Additionally, field measurements taken during the 2014 site visit indicate that approximately 2-4 ft. of scour was

observed near the left abutment and left pier face. The existing structure has over 80 years of service and it has likely experienced the incipient overtopping event multiple times. A comparison of the calculated and observed scour depths indicate that the calculated scour depths and methodology outlined in HEC-18 (abutments and pier scour) are likely conservative at the Bridge SR 2028 crossing of Sandy Run. In addition, clay deposits were observed along the right abutment in span two that may also help limit the calculated scour depths closer to those observed during the recent site visit.

## 7. Risk Assessment

A brief risk assessment was conducted by PennDOT District 6-0 during the selection of this bridge for countermeasure design. Multiple factors were taken into consideration during the selection of bridges in need of a countermeasures design, which include but are not limited to, the economic cost of repairing or replacing the bridge and the risk to public safety. As explained above the bridge was selected by PennDOT District 6-0 and was determined to be scour critical based on the highly erodible streambed, observed and calculated scour. Due to its large ADT, any damage or failure of the Bridge SR 2028 structure would severely disrupt transportation and potentially inhibit the response of emergency personal. Therefore, Bridge SR 2028 was considered an acceptable candidate for structural countermeasures.

## 8. Results and Conclusions

According to the Montgomery County FIS, Sandy Run was studied by detailed methods and it is located within a regulated floodway. The implantation of a countermeasure to protect the existing structure from scour is considered to be an addition of fill to the regulated floodway. Therefore, an H&H analysis was completed to show that the proposed countermeasure design will maintain and/or reduce water surface elevations during the PennDOT District 6-0 design (25-yr) and FEMA regulated (100-yr) flood events.

Based on the hydraulic analysis, the existing structure currently overtops during the PennDOT District 6-0 design flood event. The incipient overtopping event occurs between the 10-yr and 25-yr food, while significant overtopping of the bridge and left approach roadway is predicted during the 50-, 100-, and 500-yr flood events. Although the proposed countermeasure includes the addition of fill to the regulated floodway, the hydraulic opening will be increased by 11.9 sq-ft through the excavation of deposited material. In addition, the proposed countermeasure maintains or reduces water surface elevations within the study reach and as such, is designed in accordance with Pennsylvania Department of Transportation's DM-2, which indicates the PennDOT District 6-0 hydraulic requirements for bridges. Tables 7 and 8 provide a summary of the hydrologic analysis and hydraulic analysis explained above and the complete Summary Data Sheet can be found in Appendix. I.

Table 6 - Summary Data Sheet - Hydrologic Summary

	PennDOT Study	FEMA	Other:
Hydrology Method	HEC-HMS (2014 FIS)	PSU-IV (2001 FIS)	PA StreamStats
Drainage Area	5.48	5.48	5.48 (DA edited)
Q10 (CFS)	2,229	2,690	1,270
Q25 (CFS)	3,010	-	-
Q50 (CFS)	3,931	4,045	1,830
Q100 (CFS)	4,945	4,865	2,090
Q500 (CFS)	8,165	6,500	2,760

Table 7 - Summary Data Sheet - Hydraulic Summary

EXISTING STRUCTURE				PROPOSED STRUCTURE			
Clear Span - Normal		34.5 feet		Clear Span - Normal		34.5 feet	
Skew (relative to flow)		0 degrees		Skew (relative to flow)		0 degrees	
Minimum Under-clearance		8.8 feet		Minimum Under-clearance		11.0 feet	
Length of Channel Impacted		Approx. 130 feet		Length of Channel Impacted		Approx. 130 feet	
Number of Spans		2 spans		Number of Spans		2 spans	
Low Chord Elevation		168.5 feet		Low Chord Elevation		168.5 feet	
Hydraulic Method Used		HEC-RAS		Hydraulic Method Used		HEC-RAS	
Return Period*	Q	WSE	Velocity	Return Period*	Q	WSE	Velocity
25	3,010	172.0	8.1	25	3,010	171.9	8.0
50	3,931	174.0	2.5	50	3,931	174.0	2.4
100	4,945	175.9	2.2	100	4,945	175.9	2.1

500	8,165	178.6	1.5	500	8,165	178.6	1.5
Overtopping	< 25 yr (Pressure at 10-yr)			Overtopping	< 25 yr (Pressure at 10-yr)		

## APPENDIX D “RECOMMENDED PS&E (PLANS, SPECS, & ESTIMATE) PACKAGE”



---



FIELD CHECKLIST FOR PRELIMINARY DESIGN PERMIT COORDINATION	
<b>Proposed Structure</b>	
Type of Structure:	<u>Existing structure will remain</u>
No. of Spans:	_____ Span Lengths: _____
Piers:	Type: _____ Width: _____
Structure:	Orientation: _____
Underclearance:	_____ Skew: _____
Will Project Result in Change in Roadway Profile	<input type="checkbox"/> Yes <input checked="" type="checkbox"/> No
If Yes, Explain:	_____
<b>Environmental</b>	
USGS Quad Name:	<u>Ambler</u> Latitude: <u>40.126456 N</u> Longitude: <u>75.204033 W</u>
Stream Name:	<u>Sandy Run</u>
Stream Flow:	<input checked="" type="checkbox"/> Perennial <input type="checkbox"/> Intermittent <input type="checkbox"/> Ephemeral
Fish Habitat:	<input type="checkbox"/> Stocked <input type="checkbox"/> Wild Trout Chapter 93 Classification: <u>TSF</u>
Other Environmental Concerns:	
Threatened/Endangered Species	<input type="checkbox"/> Yes <input checked="" type="checkbox"/> No PNDI Search Date: <u>6/2/2014</u>
If Yes, Describe:	_____
Wetlands Present	<input type="checkbox"/> Yes <input checked="" type="checkbox"/> No Chap 105 Class: <input type="checkbox"/> EV <input type="checkbox"/> Other
If Yes, Impacts Anticipated	<input type="checkbox"/> Yes <input type="checkbox"/> No Cowardin Class: _____
Amount Impacted:	_____ acres Total Acreage Wetland Onsite: _____ acres
Reason for Impact:	_____
Historical, Cultural, Archeological Site	<input type="checkbox"/> Yes <input checked="" type="checkbox"/> No
If Yes, Describe:	_____
Archeological properties are present but not affected.	
National Registry/Nation landmark	<input type="checkbox"/> Yes <input checked="" type="checkbox"/> No
If Yes, Describe:	<u>See historical resources above</u>
Anticipated Mitigation Requirement:	<input type="checkbox"/> Yes <input checked="" type="checkbox"/> No
If Yes, Describe:	_____

<b>FIELD CHECKLIST FOR PRELIMINARY DESIGN PERMIT COORDINATION</b>	
<b>Proposed Structure</b>	
Type of Structure: <u>Existing structure will remain</u>	
No. of Spans: _____ Span Lengths: _____ Piers: _____ Type: _____ Width: _____ Orientation: _____	
Structure: _____ Underclearance: _____ Skew: _____	
Will Project Result in Change in Roadway Profile <input type="checkbox"/> Yes <input checked="" type="checkbox"/> No If Yes, Explain: _____	
<b>Environmental</b>	
USGS Quad Name: <u>Ambler</u> Latitude: <u>40.126456 N</u> Longitude: <u>75.204033 W</u> Stream Name: _____ Sandy Run	
Stream Flow: <input checked="" type="checkbox"/> Perennial <input type="checkbox"/> Intermittent <input type="checkbox"/> Ephemeral Fish Habitat: <input type="checkbox"/> Stocked <input type="checkbox"/> Wild Trout Chapter 93 Classification: <u>TSF</u>	
Other Environmental Concerns: Threatened/Endangered Species <input type="checkbox"/> Yes <input checked="" type="checkbox"/> No PNDI Search Date: <u>6/2/2014</u> If Yes, Describe: _____	
Wetlands Present <input type="checkbox"/> Yes <input checked="" type="checkbox"/> No Chap 105 Class: <input type="checkbox"/> EV <input type="checkbox"/> Other If Yes, Impacts Anticipated <input type="checkbox"/> Yes <input type="checkbox"/> No Cowardin Class: _____ Amount Impacted: _____ acres Total Acreage Wetland Onsite: _____ acres Reason for Impact: _____	
Historical, Cultural, Archeological Site <input type="checkbox"/> Yes <input checked="" type="checkbox"/> No If Yes, Describe: _____	
Archeological properties are present but not affected. National Registry/Nation landmark <input type="checkbox"/> Yes <input checked="" type="checkbox"/> No If Yes, Describe: <u>See historical resources above</u>	
Anticipated Mitigation Requirement: <input type="checkbox"/> Yes <input checked="" type="checkbox"/> No If Yes, Describe: _____	

DRAFT

	<b>FIELD CHECKLIST FOR PRELIMINARY DESIGN PERMIT COORDINATION</b>	
Additional Notes		
[Lined area for notes]		



## 2. Pre-Application Request Form



**If wetlands are involved:**

Type of wetland (check one): emergent  scrub-shrub  forested   
 Size of wetland (acres): \_\_\_\_\_ (nearest tenth)  
 Size of proposed impacts (acres): \_\_\_\_\_ (nearest tenth)  
 Has a wetland delineation been done? Yes:  No:   
 Has a JD been performed by the Corps? Yes:  No:

**If a stream, floodway, pond, and/or lake is involved:**

Name: \_\_\_\_\_ Sandy Run  
 Length of stream to be affected: (if applicable) \_\_\_\_\_ 200 feet  
 Area of pond or lake to be affected: (if applicable) \_\_\_\_\_ under 0.1 acres (nearest tenth)  
 Chapter 93 Stream Designation \_\_\_\_\_ TSF \_\_\_\_\_  
 FEMA Study?  Detailed Stream Study?   
 Floodway Impacts?   
 Navigable Waters?

*Upon receipt of the above information, the Department will schedule a preapplication meeting to discuss your project. At that meeting, DEP will, to the best of its ability, provide you with the information listed below as it concerns your project site.*



**DEPARTMENT USE ONLY**

	Provided	Remarks
Scenic Rivers Status	<input type="checkbox"/>	_____
Wild Trout Stream	<input type="checkbox"/>	_____ Y/N
Stocked Trout Stream	<input type="checkbox"/>	_____ Y/N
Water Quality Designations	<input type="checkbox"/>	_____
Known Water Supplies	<input type="checkbox"/>	_____
PNDI Search Form	<input type="checkbox"/>	_____
Location of State Game Lands	<input type="checkbox"/>	_____
Location of National/State Park	<input type="checkbox"/>	_____
Location of National/State Forestland	<input type="checkbox"/>	_____
Coastal Zone Management Area	<input type="checkbox"/>	_____ Y/N

**Results of Preapplication Meeting**

**If wetlands:** Acreage proposed \_\_\_\_\_  
 Modified to \_\_\_\_\_  
 Acreage reduction \_\_\_\_\_

**If streams, lakes, etc.:** Impact proposed \_\_\_\_\_  
 Modified to \_\_\_\_\_  
 Length/acreage reduction \_\_\_\_\_

**Type of 105 Permit Required:**

No Permit Req  Waiver #  105.12 (  ) General Permit #  \_\_\_\_\_  
 Full Joint Permit Application  Small Projects  EA Only   
 Qualify for SPGP Yes:  Category: I  II  III   
 No:  Reason: \_\_\_\_\_  
 Forms provided? (check one) Yes:  No:

**Meeting Summary/Notes:** \_\_\_\_\_ **Date of Meeting:** \_\_\_\_\_ **Notetaker:** \_\_\_\_\_  
 \_\_\_\_\_  
 \_\_\_\_\_  
 \_\_\_\_\_  
 \_\_\_\_\_  
 \_\_\_\_\_

### 3. PNDI Receipt

### 1. PROJECT INFORMATION

Project Name: **Camp Hill Road Bridge Maintenance,**

Date of review: **6/2/2014 2:40:36 PM**

Project Category: **Transportation, Structures and Bridges, Bridge Preservation, Restoration and/or Rehabilitation**

Project Area: **N/A**

County: **Montgomery** Township/Municipality: **Whitemarsh**

Quadrangle Name: **AMBLER** ~ ZIP Code: **19031**

Decimal Degrees: **40.126456 N, -75.204033 W**

Degrees Minutes Seconds: **40° 7' 35.2" N, -75° 12' 14.5" W**



### 2. SEARCH RESULTS

Agency	Results	Response
PA Game Commission	No Known Impact	No Further Review Required
PA Department of Conservation and Natural Resources	<b>Conservation Measure</b>	<b>No Further Review Required, See Agency Comments</b>
PA Fish and Boat Commission	No Known Impact	No Further Review Required
U.S. Fish and Wildlife Service	No Known Impact	No Further Review Required

As summarized above, Pennsylvania Natural Diversity Inventory (PNDI) records indicate that while threatened and endangered and/or special concern species and resources are in the project vicinity, no adverse impacts are anticipated. Therefore, based on the information you provided, no further coordination is required with the jurisdictional agencies. However, the jurisdictional agency/agencies recommend the project proponent/applicant follow the Conservation Measures indicated in their entirety. If a DEP permit is required for this project, DEP has the discretion to incorporate one or more Conservation Measures into its permit. This response does not reflect potential agency concerns regarding potential impacts to other ecological resources, such as wetlands.

Note that regardless of PNDI search results, projects requiring a Chapter 105 DEP individual permit or GP 5, 6, 7, 8, 9 or 11 in certain counties (Adams, Berks, Bucks, Carbon, Chester, Cumberland, Delaware, Lancaster, Lebanon, Lehigh, Monroe, Montgomery, Northampton, Schuylkill and York) must comply with the bog turtle habitat screening requirements of the PASPGP.

### RESPONSE TO QUESTION(S) ASKED

Q1: "Will any and all on-land (non-aquatic) disturbance occur in or on an existing building, parking lot, driveway, road, road shoulder, street, runway, paved area, railroad bed, maintained (periodically mown) lawn, crop agriculture field or maintained orchard?"

Your answer is: 1. Yes

### 3. AGENCY COMMENTS

Regardless of whether a DEP permit is necessary for this proposed project, any potential impacts to threatened and endangered species and/or special concern species and resources must be resolved with the appropriate jurisdictional agency. In some cases, a permit or authorization from the jurisdictional agency may be needed if adverse impacts to these species and habitats cannot be avoided.

These agency determinations and responses are **valid for two years** (from the date of the review), and are based on the project information that was provided, including the exact project location; the project type, description, and features; and any responses to questions that were generated during this search. If any of the following change: 1) project location, 2) project size or configuration, 3) project type, or 4) responses to the questions that were asked during the online review, the results of this review are not valid, and the review must be searched again via the PNDI Environmental Review Tool and resubmitted to the jurisdictional agencies. The PNDI tool is a primary screening tool, and a desktop review may reveal more or fewer impacts than what is listed on this PNDI receipt. The jurisdictional agencies **strongly advise against** conducting surveys for the species listed on the receipt prior to consultation with the agencies.

#### PA Game Commission

**RESPONSE:** No Impact is anticipated to threatened and endangered species and/or special concern species and resources.

#### PA Department of Conservation and Natural Resources

**RESPONSE:** Conservation Measure: Please avoid the introduction of invasive species in order to protect the integrity of nearby plant species of special concern. Voluntary cleaning of equipment/vehicles, using clean fill and mulch, and avoiding planting invasive species (<http://www.dcnr.state.pa.us/forestry/invasivetutorial/index.htm>) will help to conserve sensitive plant habitats.

**DCNR Species:** (Note: The PNDI tool is a primary screening tool, and a desktop review may reveal more or fewer species than what is listed below. After desktop review, if a botanical survey is required by DCNR, we recommend the DCNR Botanical Survey Protocols, available here: [http://www.gis.dcnr.state.pa.us/hgis-er/PNDI\\_DCNR.aspx](http://www.gis.dcnr.state.pa.us/hgis-er/PNDI_DCNR.aspx).)

**Scientific Name:** Eupatorium album var. album

**Common Name:** White Thoroughwort

**Current Status:** Special Concern Species\*

**Proposed Status:** Endangered

### PA Fish and Boat Commission

**RESPONSE:** No Impact is anticipated to threatened and endangered species and/or special concern species and resources.

### U.S. Fish and Wildlife Service

**RESPONSE:** No impacts to federally listed or proposed species are anticipated. Therefore, no further consultation/coordination under the Endangered Species Act (87 Stat. 884, as amended; 16 U.S.C. 1531 *et seq.*) is required. Because no take of federally listed species is anticipated, none is authorized. This response does not reflect potential Fish and Wildlife Service concerns under the Fish and Wildlife Coordination Act or other authorities.

\* Special Concern Species or Resource - Plant or animal species classified as rare, tentatively undetermined or candidate as well as other taxa of conservation concern, significant natural communities, special concern populations (plants or animals) and unique geologic features.

\*\* Sensitive Species - Species identified by the jurisdictional agency as collectible, having economic value, or being susceptible to decline as a result of visitation.

## 4. DEP INFORMATION

The Pa Department of Environmental Protection (DEP) requires that a signed copy of this receipt, along with any required documentation from jurisdictional agencies concerning resolution of potential impacts, be submitted with applications for permits requiring PNDI review. For cases where a "Potential Impact" to threatened and endangered species has been identified before the application has been submitted to DEP, the application should not be submitted until the impact has been resolved. For cases where "Potential Impact" to special concern species and resources has been identified before the application has been submitted, the application should be submitted to DEP along with the PNDI receipt. The PNDI Receipt should also be submitted to the appropriate agency according to directions on the PNDI Receipt. DEP and the jurisdictional agency will work together to resolve the potential impact(s). See the DEP PNDI policy at <http://www.naturalheritage.state.pa.us>.

**5. ADDITIONAL INFORMATION**

The PNDI environmental review website is a preliminary screening tool. There are often delays in updating species status classifications. Because the proposed status represents the best available information regarding the conservation status of the species, state jurisdictional agency staff give the proposed statuses at least the same consideration as the current legal status. If surveys or further information reveal that a threatened and endangered and/or special concern species and resources exist in your project area, contact the appropriate jurisdictional agency/agencies immediately to identify and resolve any impacts.

For a list of species known to occur in the county where your project is located, please see the species lists by county found on the PA Natural Heritage Program (PNHP) home page ([www.naturalheritage.state.pa.us](http://www.naturalheritage.state.pa.us)). Also note that the PNDI Environmental Review Tool only contains information about species occurrences that have actually been reported to the PNHP.

**6. AGENCY CONTACT INFORMATION**

**PA Department of Conservation and Natural Resources**  
 Bureau of Forestry, Ecological Services Section  
 400 Market Street, PO Box 8552, Harrisburg, PA.  
 17105-8552  
 Fax:(717) 772-0271

**U.S. Fish and Wildlife Service**  
 Endangered Species Section  
 315 South Allen Street, Suite 322, State College, PA.  
 16801-4851  
 NO Faxes Please.

**PA Fish and Boat Commission**  
 Division of Environmental Services  
 450 Robinson Lane, Bellefonte, PA. 16823-7437  
 NO Faxes Please

**PA Game Commission**  
 Bureau of Wildlife Habitat Management  
 Division of Environmental Planning and Habitat Protection  
 2001 Elmerton Avenue, Harrisburg, PA. 17110-9797  
 Fax:(717) 787-6957

**7. PROJECT CONTACT INFORMATION**

Name: \_\_\_\_\_  
 Company/Business Name: \_\_\_\_\_  
 Address: \_\_\_\_\_  
 City, State, Zip: \_\_\_\_\_  
 Phone:(\_\_\_\_) \_\_\_\_\_ Fax:(\_\_\_\_) \_\_\_\_\_  
 Email: \_\_\_\_\_

**8. CERTIFICATION**

I certify that ALL of the project information contained in this receipt (including project location, project size/configuration, project type, answers to questions) is true, accurate and complete. In addition, if the project type, location, size or configuration changes, or if the answers to any questions that were asked during this online review change, I agree to re-do the online environmental review.

\_\_\_\_\_ date  
 applicant/project proponent signature

#### 4. Project Description

This is a research project that includes installing partially grouted riprap (PGR) at a selected scour critical bridge site **BMS# 46 2028 0020 0000** and protecting exposed foundations/footings for both abutments and the pier. The research project is a collaborative effort between PennDOT/District 6-0, Temple University and various environmental regulating agencies including PADEP and USACOE. Draft PGR design guidelines have been developed, reviewed and revised as part of the research effort. The technical part of the work consists of constructing partially grouted riprap (PGR) countermeasure “in the dry” and “in the wet” in accordance with PennDOT Standard Specification Publication 408. PGR construction consists of furnishing and placing rock riprap as a scour countermeasure at locations shown in the construction plans/drawings and described in the specifications. The riverbed will require some excavation and bed preparation including verifying the proper elevations depicted on the plans. The riprap shall be placed on top of a filter layer consisting of a combined geotextile fabric and 6-inch layer of granular materials as specified in the construction plans and specifications. The voids of the riprap are then partially filled with a Portland cement-based grout by hose or tremie. The final configuration results in a stable armor layer that retains approximately one-half to two-thirds of the void space of the original riprap. PGR placement will include grouting in the wet and in the dry. During grouting operations water quality monitoring testing will be followed according to the design specifications and field observations. For this research project PennDOT/District 6-0 is considered the designer and the environmental permit will also be submitted by PennDOT/District 6-0.

#### 5. TS&L Letter

April 28, 2015[Type text]

Pennsylvania Department of Transportation

7000 Geerdes Blvd.

King of Prussia, PA 19406

Attn: Ms. Christine Reilly, P.E.

Acting District 6 Executive

**Re: Type, Size & Location Submission**

**Camp Hill Road over Sandy Run**

**BMS ID # 46 2028 0020 0000 (STV #210)**

Montgomery County Whitemarsh Township

Temple/CHA Research Contract No. 4400011166

Dear Ms. Reilly:

In accordance with DM-4, Part A, Table 1.9-3, please find attached the TS&L plan, and preliminary cost estimate for the above referenced structure. This is submitted for review by the Temple/CHA Team in connection with the bridge scour research project entitled “ ***Environmental and Cost Effectiveness of Partially Grouted Riprap for Scour Countermeasure***”. Please note the applicable Hydrologic and Hydraulic information along with the summary of scour countermeasure design parameters were submitted on November 5, 2014. PennDOT provided comments and preliminary H&H approval in January 2015.

In accordance with DM-4, Part A, Section 1.9.3.3(a), we are including the following:

- |     |                       |  |
|-----|-----------------------|--|
| (1) | Location              | Camp Hill Road over Sandy Run; <b>SR 2028</b>  |
| (2) | Recommended Structure | Existing concrete encased steel girder superstructure will remain.   |
| (3) | Span                  | Two spans, each measuring 16'-0" clear, will remain.   |
| (4) | Roadway Width         | Existing roadway will remain (curb to curb distance is 24').   |
| (5) | Skew Angle            | Existing structure skew of 50° will remain, with an approximate flow angle of attack of roughly 10° impacting the left abutment.   |
| (6) | Vertical Clearance    | Vertical clearance above deck is not applicable. Below deck, PGR countermeasures will be installed to match existing upstream and downstream streambed elevations, and will not reduce the original hydraulic opening. Original vertical height (streambed to low chord) was 10-11'. |
|     | Horizontal Clearance  | Existing horizontal clearance above deck will remain.  |

- |      |                    |   |
|------|--------------------|---|
| (7)  | Substructure Type  | Existing concrete substructures will remain. Scour countermeasures will be installed along the abutments and pier, across the full channel. |
| (8)  | Deck Joints        | Existing joints will remain.  |
| (9)  | Bearings           | Existing bearings will remain.  |
| (10) | Drainage           | Existing drainage will remain.  |
| (11) | Design Methodology | N/A (Superstructure not to be touched).<br><br>Bridge countermeasures (PGR Research PennDOT/Temple/CHA)                                     |

The following information is required as per DM-4, Part A, Section 1.9.3.3(e):

- (1) State Route 2028, Section       (TBD)      , Camp Hill Road, Montgomery County, Whitmarsh Township
- (2) Program: Temple Research  
  
Funding: FHWA/PennDOT  
  
Temple Research Project No.: 440001116  
  
MPMS Number: (TBD)
- (3) Designer: PennDOT
- (4) Proposed structure: The existing concrete encased steel girder superstructure and concrete substructures (1 pier and 2 abutments) will remain. Scour countermeasures will be placed along the abutments and pier, across the full channel width.
- (5) Design traffic data: N/A – bridge to remain.  
  
Class of Highway: Local
- (6) This is a scour countermeasure project. There is no change to the grade of Camp Hill Road, and therefore no formal Line & Grade submission.
- (7) PGR will be placed to re-establish the original streambed elevation, after sediment is

excavated out. There will be no reduction to the original hydraulic opening at this bridge.

- (8) The existing bridge is located on a free access roadway.
- (9) Existing bridge and roadway will remain. Typical sections of countermeasure installation are provided with the preliminary plan sheets.
- (10) Permit will be obtained by PennDOT. Information will be submitted in April 2015.  
Construction is planned for September 2015
- (11) An onsite meeting occurred on July 30, 2014, with representatives from PennDOT, Temple and CHA. A DFV submission is not anticipated for this experimental / maintenance work within the stream channel.
- (12) a,b,c: Existing bridge will remain. No rehabilitation of the structure will be completed.

d. The proposed scope of countermeasure work in the streambed consists of, references to left and right are looking downstream:

- i. Provide access to the Right side of Span 2 (upstream and downstream).
- ii. Install turbidity curtain in the middle of Span 2 prior to excavation in Span 2.
- iii. Remove sediments per contract drawings and install a temporary flow diversion channel along the right side of Span 2 (adjacent to the Right abutment). **End Phase 1**
- iv. Install Phase 2 water diversion barrier along the upstream left bank area to divert the majority of the flow into the channel along the right abutment (right side of span 2).
- v. Install turbidity curtain for Phase 2 work. Contained work area will include all of span 1 (left side) and the left half of span 2 (right side).
- vi. Excavate excess material and prepare/level streambed. Verify bed elevations.
- vii. Install filter material (geotextile and gravel layer) verify bed elevations.
- viii. Place Modified R-6 rock along all of span 1 (left side) and the left half of span 2. Verify bed elevations.

- ix. Place grout “in the wet” along all of span 1 (left side) and the left half of span 2.
- x. Follow water quality testing protocol included in the design plans.
- xi. Place non-grouted rock along the upstream left bank area.
- xii. Remove turbidity curtain and flow diversion barrier (upstream left bank area) **End Phase 2.**
- xiii. Install Phase 3 cofferdams upstream and downstream in the right side of span 2. Contained work area will be the right half of span 2 (along the right abutment)
- xiv. Excavate excess material and prepare/level streambed. Verify bed elevations.
- xv. Install filter material (geotextile and gravel layer) verify bed elevations.
- xvi. Place Modified R-6 rock along all of span 1 (left side) and the left half of span 2. Verify bed elevations.
- xvii. Place grout “in the dry” along the right half of span 2 (right side).
- xviii. Follow water quality testing protocol included in the design plans.
- xix. Place non-grouted rock along the upstream and downstream right bank areas.
- xx. Remove phase 3 upstream and downstream cofferdams **End Phase 3.**

- (13) No railroads are involved for this scour countermeasure installation.
- (14) There is no RSGER submission for this scour countermeasure installation.
- (15) Future pedestrian needs are not applicable for this scour countermeasure project.
- (16) Environmental issues will be monitored by PADEP and USACOE. Coordination for this research project is being led by PADEP Central Office.
- (17) Overhead power lines run above both the upstream and downstream fasciae. There are potential water hazards that may arise during high flow events.

Quantities and costs were determined based on preliminary plans. The revised conceptual cost estimate for installing the PGR countermeasure in the wet and dry is **\$230,000**. Quality Assurance Forms are not included.

Sincerely,

---

## 6. E&S Preliminary Plans





KUTNER

**SUGGESTED CONSTRUCTION SEQUENCE**

- PHASE 1**
1. MARK LIMITS OF DISTURBED AREA TO BE WORKED. INSTALL CORNER FLAGS AS INDICATED AND/OR AS EXISTING BY PROJECT CONTRACTOR.
  2. CONSTRUCT ROCK CONSTRUCTION ENTRANCE (SEE PLAN FOR PHASE 1 AND PHASE 2).
  3. INSTALL TIGHTLY CURVED ENDS OF SPAN 1 TO MATCH SET LOCATION ON SPAN 2.
  4. LOCATE AND INSTALL A TEMPORARY EROSION CONTROL CHANNEL ALONG THE RIGHT SIDE OF SPAN 1 ADJACENT TO THE RIGHT ABUTMENT.

- PHASE 2**
1. INSPECT ALL FOUNDATION DESIGN AND SEDIMENT CONTROL DESIGN.
  2. CONSTRUCT ROCK CONSTRUCTION ENTRANCE (SEE PLAN FOR PHASE 2).
  3. INSTALL PHASE 2 ENERGY DISSIPATION BARRIERS ALONG THE UPSTREAM LEFT BANK AREA TO DIRECT THE FLOW INTO THE DOWNSTREAM PLUG OF SEDIMENT CHANNEL ALONG THE RIGHT ABUTMENT (RIGHT SIDE OF SPAN 2).
  4. INSTALL TIGHTLY CURVED ENDS FOR PHASE 2 BARRIERS. VERIFY AND BLANKET TOP.
  5. INSTALL EROSION CONTROL AND GRAVEL LAYER (SEE PLAN FOR SPECIFICATIONS).
  6. PLACE AND LIGHTLY RAMP UP IN ALL OF SPAN 1 (LEFT BANK) AND THE LEFT SIDE OF SPAN 2. VERIFY AND BLANKET TOP.
  7. PLACE AND LIGHTLY RAMP UP IN ALL OF SPAN 1 (LEFT BANK) AND THE LEFT SIDE OF SPAN 2. VERIFY AND BLANKET TOP.
  8. PLACE AND LIGHTLY RAMP UP IN ALL OF SPAN 1 (LEFT BANK) AND THE LEFT SIDE OF SPAN 2. VERIFY AND BLANKET TOP.
  9. PLACE AND LIGHTLY RAMP UP IN ALL OF SPAN 1 (LEFT BANK) AND THE LEFT SIDE OF SPAN 2. VERIFY AND BLANKET TOP.
  10. PLACE AND LIGHTLY RAMP UP IN ALL OF SPAN 1 (LEFT BANK) AND THE LEFT SIDE OF SPAN 2. VERIFY AND BLANKET TOP.
  11. PLACE AND LIGHTLY RAMP UP IN ALL OF SPAN 1 (LEFT BANK) AND THE LEFT SIDE OF SPAN 2. VERIFY AND BLANKET TOP.

- PHASE 3**
1. INSPECT ALL FOUNDATION DESIGN AND SEDIMENT CONTROL DESIGN.
  2. INSTALL PHASE 3 COERCIONS AND SPAN 2.
  3. LOCATE AND INSTALL A TEMPORARY EROSION CONTROL CHANNEL ALONG THE RIGHT SIDE OF SPAN 2.
  4. INSTALL PHASE 3 ENERGY DISSIPATION BARRIERS ALONG THE UPSTREAM LEFT BANK AREA TO DIRECT THE FLOW INTO THE DOWNSTREAM PLUG OF SEDIMENT CHANNEL ALONG THE RIGHT ABUTMENT (RIGHT SIDE OF SPAN 2).
  5. INSTALL TIGHTLY CURVED ENDS FOR PHASE 3 BARRIERS. VERIFY AND BLANKET TOP.
  6. PLACE AND LIGHTLY RAMP UP IN ALL OF SPAN 1 (LEFT BANK) AND THE LEFT SIDE OF SPAN 2. VERIFY AND BLANKET TOP.
  7. PLACE AND LIGHTLY RAMP UP IN ALL OF SPAN 1 (LEFT BANK) AND THE LEFT SIDE OF SPAN 2. VERIFY AND BLANKET TOP.
  8. PLACE AND LIGHTLY RAMP UP IN ALL OF SPAN 1 (LEFT BANK) AND THE LEFT SIDE OF SPAN 2. VERIFY AND BLANKET TOP.
  9. PLACE AND LIGHTLY RAMP UP IN ALL OF SPAN 1 (LEFT BANK) AND THE LEFT SIDE OF SPAN 2. VERIFY AND BLANKET TOP.

**SEEDING AND MULCHING SPECIFICATIONS**

- PERMANENT SEEDING - FORMULA B**
- USE ON NON-SLOPED, LANDSCAPED AREAS WHERE MOWING IS ANTICIPATED.
- PERMANENT SEEDING - FORMULA D**
- USE ON FINISHED GRADE (3:1 OR STEEPER) AND IN DRAINAGE CHANNELS/ SWALES.
- TEMPORARY SEEDING - FORMULA E**
- USE ON UNFINISHED GRADED AREAS WHERE IT IS DESIRABLE TO ESTABLISH A TEMPORARY VEGETATION COVER.

**SEEDING TABLE**

FORMULA AND SPECIES	MATERIAL X			MAX. S	SEEDING RATE (LBS. PER 1000 SF)
	S SF PER FT	PURITY	GERMINATION		
<b>FORMULA B</b>					<b>21.0 TOTAL</b>
• PERMANENT HYDRASS SECTURM (LULIUM PERENN)	20	97	90	0.10	4.0
• CRACKING RED PEGGLE OR CRACKING PEGGLE (PASTORA RUBRA OR SSP COMUNITA)	30	97	85	0.10	6.0
• HYDRASS BLUEGRASS SECTURE (PRA PRATENSIS)	60	97	80	0.15	11.0
<b>FORMULA D</b>					<b>21.0 TOTAL</b>
• TALL PEGGLE (PASTORA BOUNDANCE VAR. HYBRIDUS 311)	60	95	85	0.15	13.0
• CRACKING RED PEGGLE OR CRACKING PEGGLE (PASTORA RUBRA OR SSP COMUNITA)	30	90	85	0.15	6.0
• ANNUAL HYDRASS (LULIUM MULTIFLORUM)	10	95	90	0.10	2.0
<b>FORMULA E</b>					<b>10.00 TOTAL</b>
• ANNUAL HYDRASS (LULIUM MULTIFLORUM)	100	95	90	0.10	10.00

**SOIL SUPPLEMENTS TABLE**

FORMULA	SOIL SUPPLEMENTS
<b>FORMULA B, D</b>	44-0-0-00 ANALYTICAL LOWPHOSPH 800 LB/1000 SQYD
	10-20-20 ANALYTICAL COMMERCIAL FERTILIZER 140 LB/1000 SQYD
	38-0-0 UREANUM FERTILIZER 50 LB/1000 SQYD
	33-0-0 TO 38-0-0 SULFUR COATED UREA FERTILIZER 38 LB/1000 SQYD TO 50 LB/1000 SQYD
	31-0-0 3800 FERTILIZER 61 LB/1000 SQYD

IF THE STUDY AREA IS ADJACENT WITH SEEDS FORMULA B, D, E AT A WITHIN RATE OF 1-2000 LB PER 1-2000 SQYD.  
 PLACE EROSION CONTROL MULCH BLANKET ON AREAS WITH SEEDS FORMULA B, D, PLACE EROSION CONTROL MULCH BLANKET ON AREAS WITH SEEDS FORMULA E WHERE THE SLOPES ARE 3:1 OR STEEPER.

DISTRICT	CITY	ROUTE	SECTION	SHEET
6-0	MONTGOMERY	2028	XX	2 OF 3
MILITARY TOWNSHIP				
SECTION		DATE		BY
SECTION		DATE		BY

**NOTES**

1. INSPECT THE ENTRANCE ENTRY. REMOVE ALL SEDIMENT DEPOSITION ON THE PUBLIC HIGHWAYS AND RETURN TO THE CONSTRUCTION SITE. MOWING OF THE HIGHWAY WILL NOT BE PERMITTED.
2. MAINTAIN THE SPECIFIED ROCK CONSTRUCTION ENTRANCE TECHNIQUES. PLACE ADDITIONAL ROCK THROUGH ROCK BARRIERS CLOSING WITH SEDIMENT.
3. MAINTAIN STOCKPILE OF ASBESTO NO. 1 COARSE AGGREGATE.
4. CONSTRUCT A MOUNTABLE SOIL ONLY HIGH 8" HIGH COVER CANNOT BE PROVIDED OVER THE PILE.
5. SATISFACTORILY REMOVE MATERIALS AS PER SPECIFICATION IN PUBLICATION 406. SECTION 849 BEEN ROCK CONSTRUCTION ENTRANCE IS NO LONGER NEEDED.
6. PROVIDE GEOTEXTILE MATERIAL MEETING THE REQUIREMENTS OF PUBLICATION 406, SECTION 176. FURNISH AND INSTALL IN ACCORDANCE WITH PUBLICATION 406, SECTION 212. PROVIDE GEOTEXTILE ALONG ALL EXPOSED AREAS WITH DRAINAGE CONTROL.
7. CONSTRUCT ROCK CONSTRUCTION ENTRANCE WITHIN THE RIGHT-OF-WAY OF EXISTING ROAD. CHANNEL MAY BE CONSTRUCTED ON A SLOPE IF AGGREGATE FILL OUT RIGHT DISTANCE IS AVAILABLE.
8. INSTALL TEMPORARY SILT FENCE ALONG CONSTRUCTION ENTRANCES AS NEEDED AND AS DIRECTED BY THE INSPECTOR.

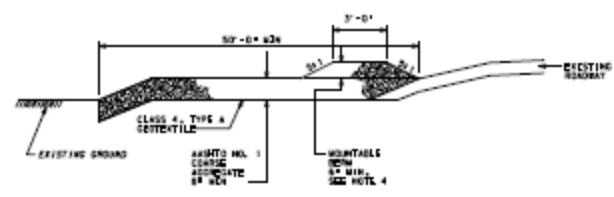
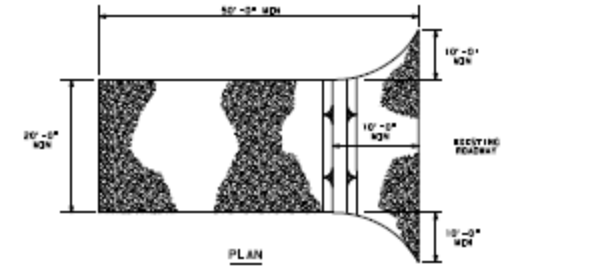

**PROFILE**  
**ROCK CONSTRUCTION ENTRANCE**

N.T.S.  
 ITEM NO. 0203-0001 CLASS 1 CRUSHED  
 ITEM NO. 0203-0014 COVERABLE CLASS 4, TYPE A  
 ITEM NO. 0203-0035 NO.1 COARSE AGGREGATE

**EROSION AND SEDIMENT POLLUTION CONTROL PLAN**

DATE	REV	BY



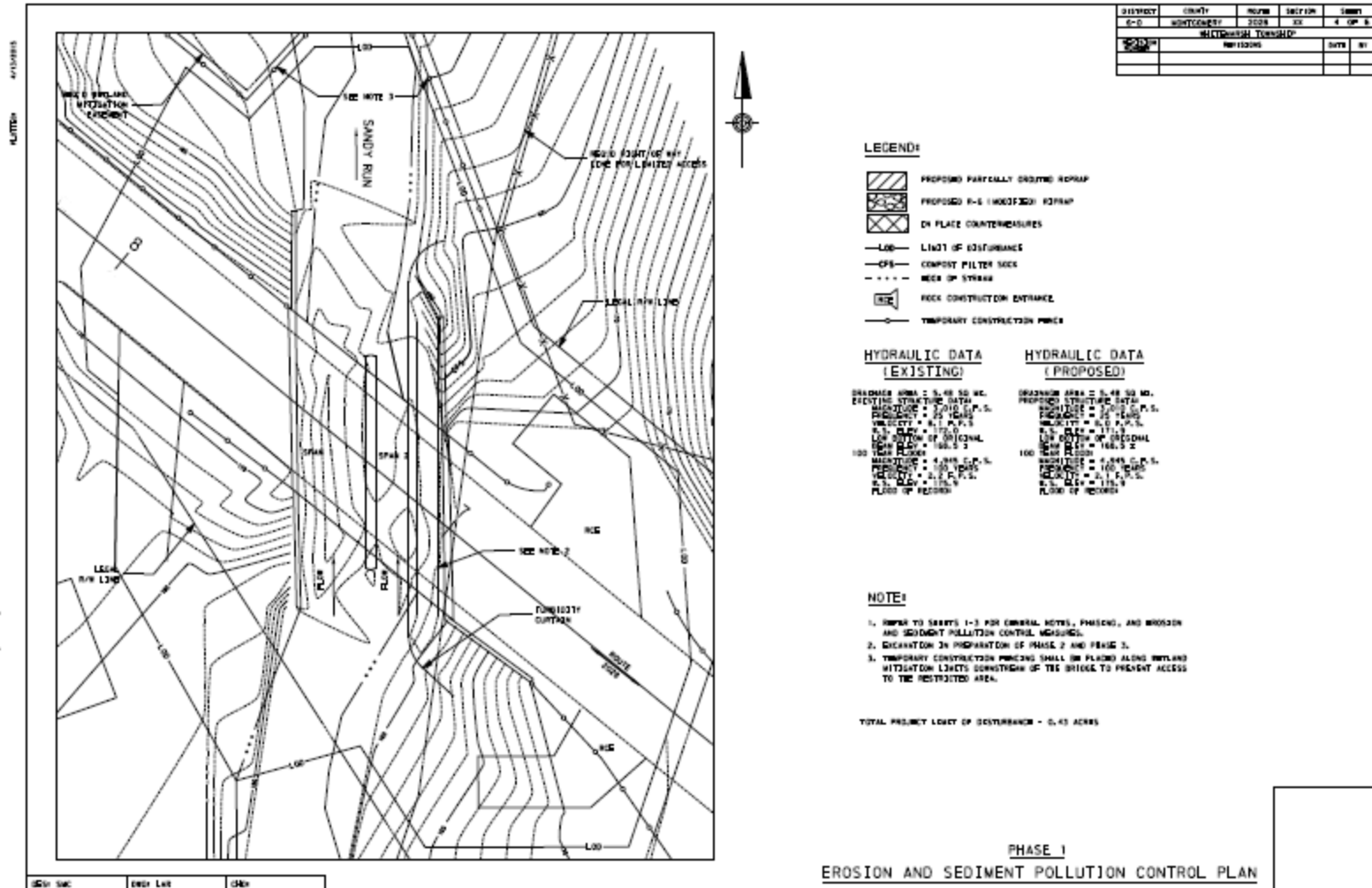

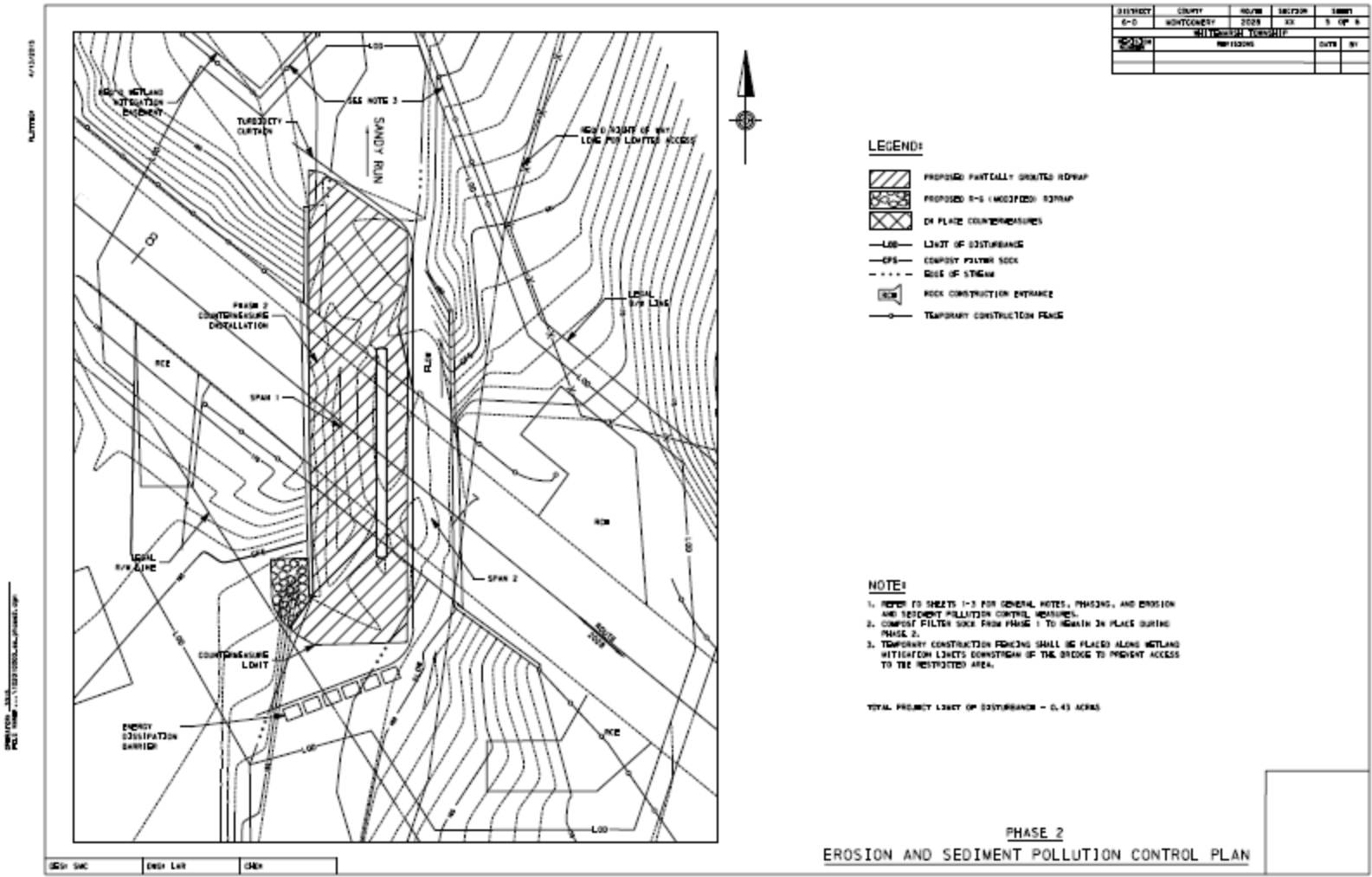

DISTRICT	COUNTY	TOWNSHIP	RANGE	SECTION	SEWER
6-D	MONTGOMERY	2028	12	3	OF 4
MONTGOMERY TOWNSHIP					
PROJECT		DATE		BY	

**LEGEND:**

- PROPOSED PARTIALLY GRADED ROADWAY
- PROPOSED S-G (MODIFIED) STREAM
- DIAPHRAGM COUNTERMEASURES
- LIMIT OF DISTURBANCE
- COMPOSITE POLYMER SOCK
- ROCK OF STREAM
- ROCK CONSTRUCTION ENTRANCE
- TEMPORARY CONSTRUCTION FENCING

**NOTE:**

1. REFER TO SHEETS 1-3 FOR GENERAL NOTES, PHASING, AND EROSION AND SEDIMENT POLLUTION CONTROL MEASURES.
2. COMPOSITE FILTER SOCKS FROM PHASE 1 TO REMAIN IN PLACE DURING PHASE 2.
3. TEMPORARY CONSTRUCTION FENCING SHALL BE PLACED ALONG WETLAND MITIGATION LIMITS DURING CONSTRUCTION OF THE BRIDGE TO PREVENT ACCESS TO THE RESTRICTED AREA.

TOTAL PROJECT LIMIT OF DISTURBANCE = 0.43 ACRES

**PHASE 2  
EROSION AND SEDIMENT POLLUTION CONTROL PLAN**

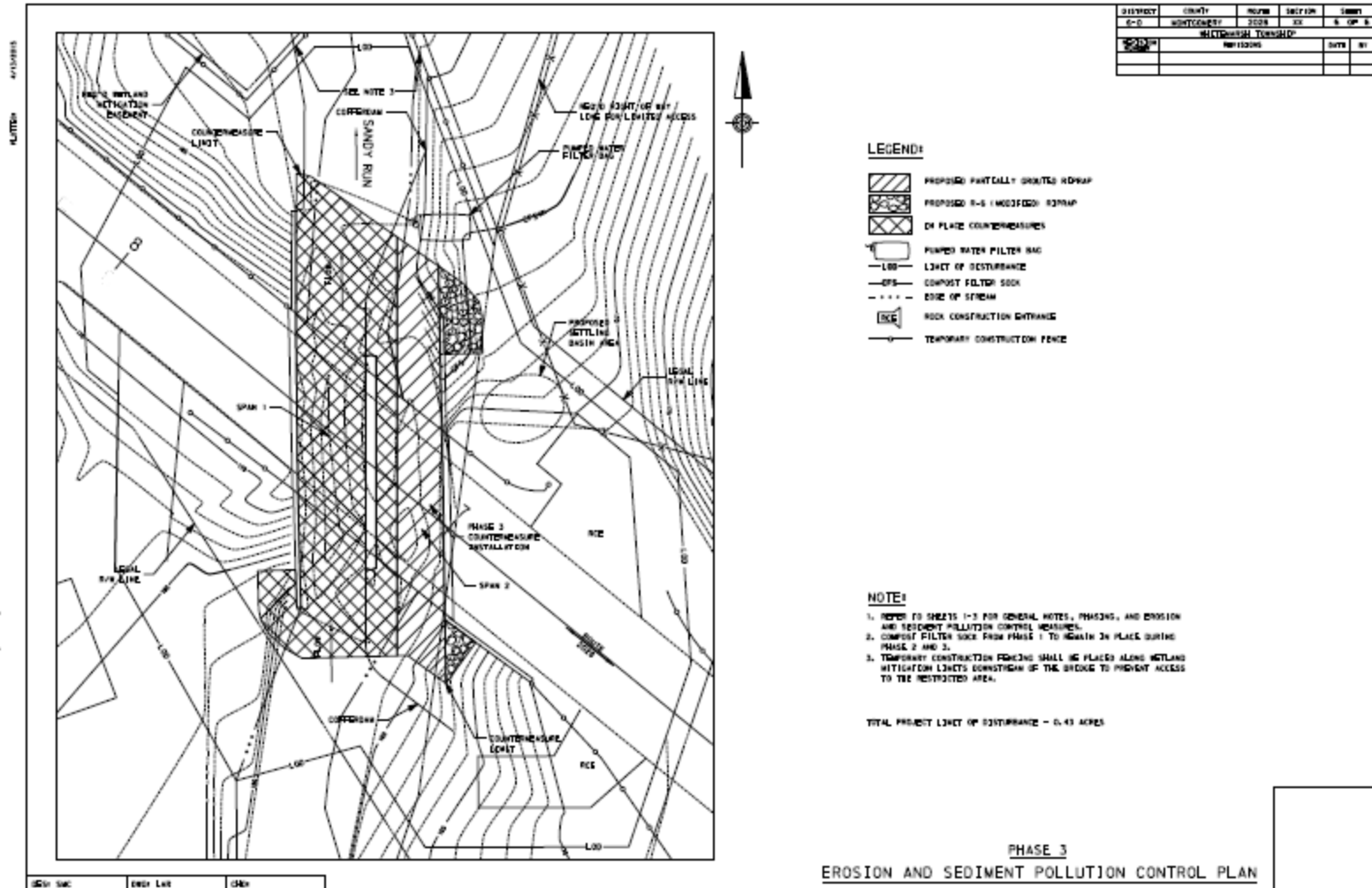

DISTRICT	COUNTY	TOWNSHIP	RANGE	SECTION	GRID
1-0	MONTGOMERY	2028	14	8	OP 8
MICHIGAN TOWNSHIP					
MICHIGAN					
DATE: 8/1					

**PHASE 3**  
**EROSION AND SEDIMENT POLLUTION CONTROL PLAN**



## 7. OHW

DATE: 11/15/2018

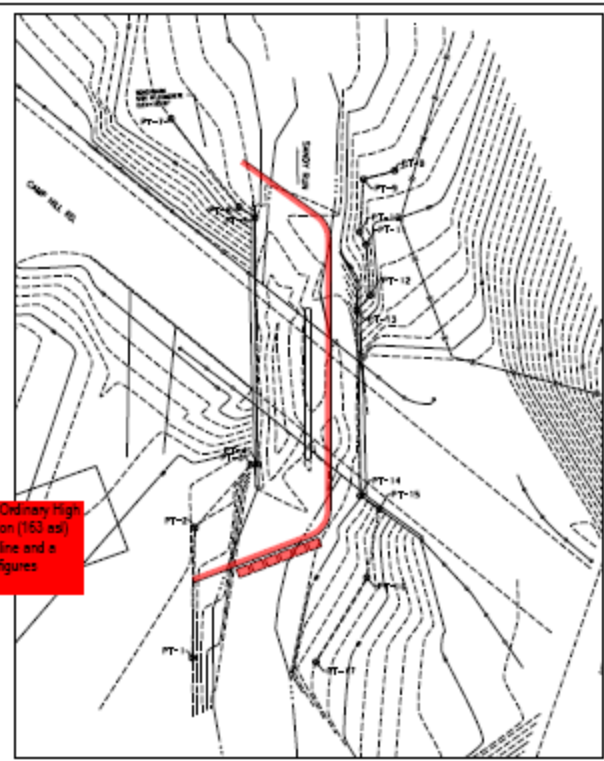
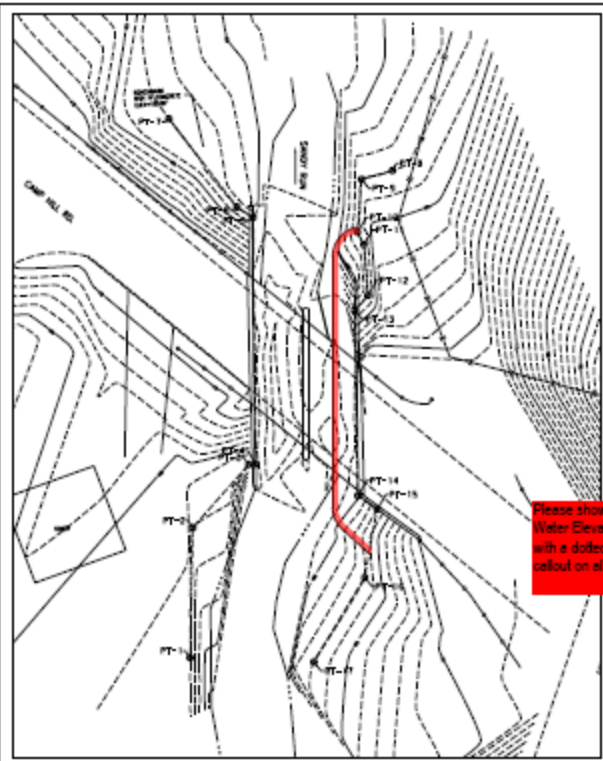

**TEMPORARY CONDITION**

PHASE II  
 TEMPORARY FILL = 26 CY  
 PERMANENT FILL = 0 CY  
 10 0 10 20 FEET

**STREAM IMPACT = XXX LF**

**LEGEND**

- OHW (ORDINARY HIGH WATER) LEVEL
- EDGE OF STREAM
- █ TEMPORARY FILL BELOW OHW
- █ PERMANENT FILL BELOW OHW

**TEMPORARY CONDITION**

PHASE II  
 TEMPORARY FILL = 48 CY  
 PERMANENT FILL = 0 CY  
 10 0 10 20 FEET

**STREAM IMPACT = XXX LF**

FILL BELOW ORDINARY HIGH WATER LINE

PROJECT	NO. 1	NO. 2	NO. 3	NO. 4
DATE	11/15/2018	11/15/2018	11/15/2018	11/15/2018
MONTGOMERY COUNTY, MARYLAND				
MONTGOMERY COUNTY, MARYLAND				
DATE	11/15/2018	11/15/2018	11/15/2018	11/15/2018

PT#	EASTING	NORTHING
PT-1	1262581.1	1632222.1
PT-2	1262581.1	1632222.1
PT-3	1262581.1	1632222.1
PT-4	1262581.1	1632222.1
PT-5	1262581.1	1632222.1
PT-6	1262581.1	1632222.1
PT-7	1262581.1	1632222.1
PT-8	1262581.1	1632222.1
PT-9	1262581.1	1632222.1
PT-10	1262581.1	1632222.1
PT-11	1262581.1	1632222.1
PT-12	1262581.1	1632222.1
PT-13	1262581.1	1632222.1
PT-14	1262581.1	1632222.1
PT-15	1262581.1	1632222.1

NUMBER

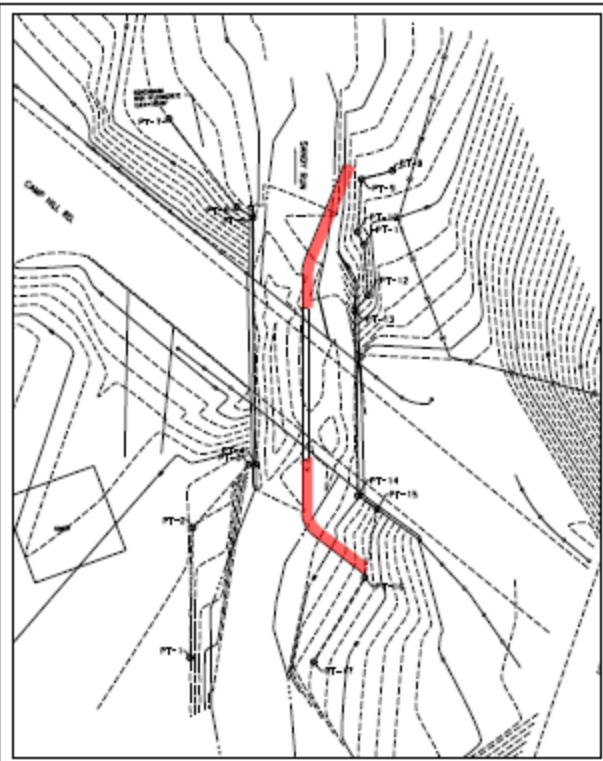

TEMPORARY CONDITION

UPRAISE 31  
 TEMPORARY FILL = 36 CY  
 PERMANENT FILL = 0 CY  
 10 0 10 20 FEET

LEGEND

- OHL (ORDINARY HIGH WATER LEVEL)
- EDGE OF STREAM
- █ TEMPORARY FILL BELOW OHL
- █ PERMANENT FILL BELOW OHL

STREAM IMPACT = XXX LF

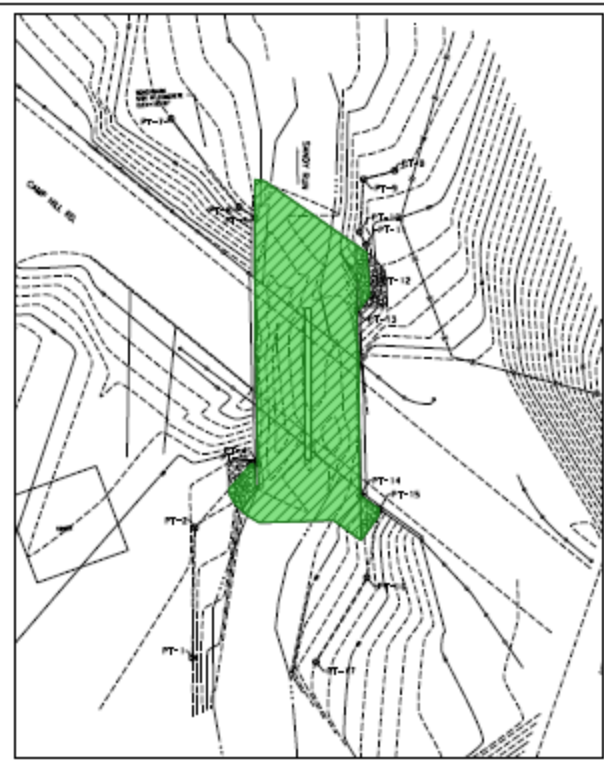

PROPOSED CONDITION

TEMPORARY FILL = 0 CY  
 PERMANENT FILL = 282 CY  
 10 0 10 20 FEET

STREAM IMPACT = XXX LF

FILL BELOW ORDINARY HIGH WATER LINE

DISTRICT	UNIT	NO./A	SECTION	SHEET
6	MONTGOMERY	2024		2 OF 2
METRAIRRAISE TOWNSHIP				
PROJECT		NO. 133045		DWM BT

## APPENICES FOR APPENDIX C

---