

# PennDOT Project Information

## **Virtual Public Meeting June 2026**

**SR 3014 Section 554  
SR 3014 over Big Run**

**GPI**



## SR 3014 Section 554 Jefferson County, PA

## Purpose of Presentation

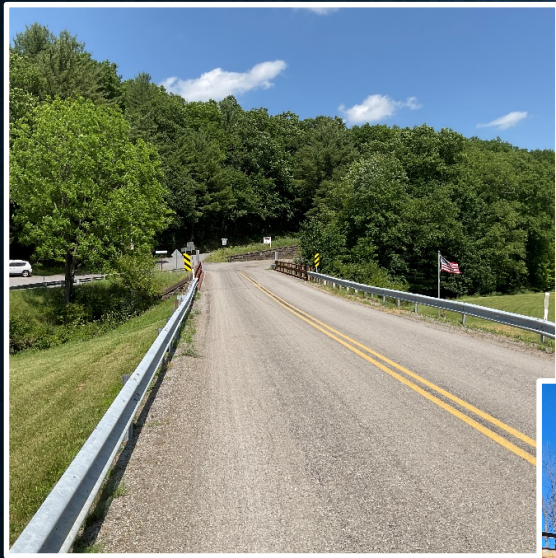

- The purpose of this presentation is to introduce the project to the public, gather feedback, and present the proposed design.
- The intent of the project is to provide a sustainable crossing on SR 3014 over Big Run.

SR 3014 over Big Run

## SR 3014 Section 554 Jefferson County, PA

## Project Location & Summary

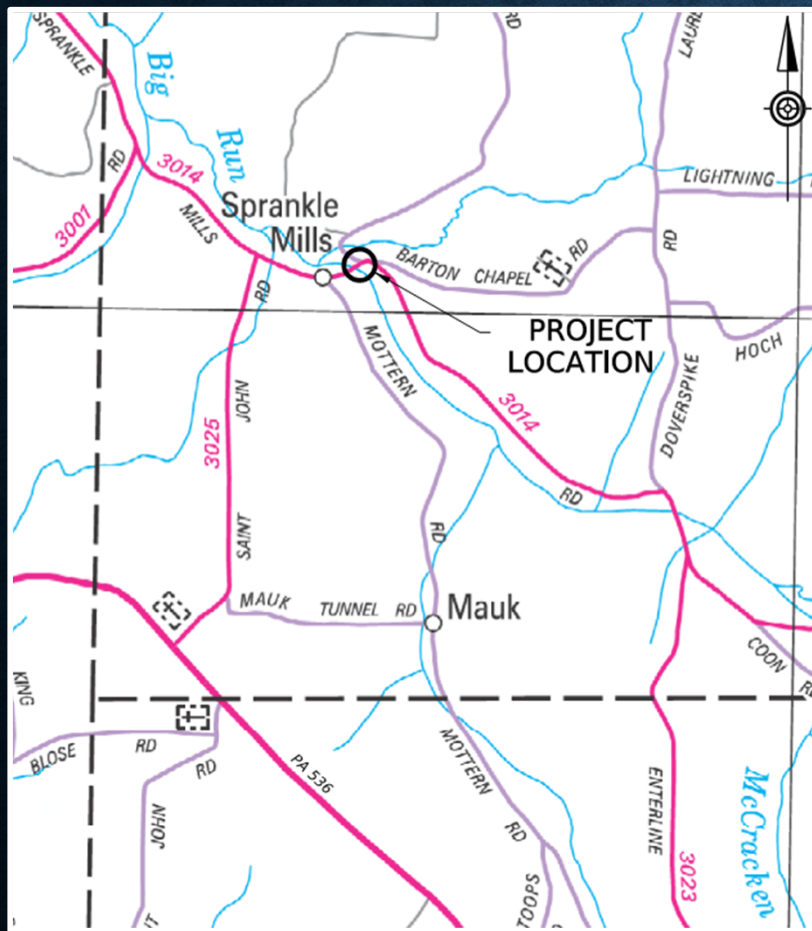

- Bridge Replacement Project located in Oliver Township, Jefferson County, PA
- SR 3014 over Big Run is located close to the intersection of T-359 Mauk Hill Road and T-891 Barton Chapel Road.
- Existing Structure – 70 ft long single-span steel rolled beam bridge
- Proposed Structure – 90 ft long single-span composite PA Bulb-Tee beam bridge with one full height and one integral abutment
- Estimated Construction Cost – \$2.5M - \$5M Federally Funded

## SR 3014 Section 554 Jeferson County, PA

## Project Improvements



**Existing Structure**

- Remove the existing fair condition single-span steel rolled beam bridge.
- Construct a proposed 90-foot long single-span composite PA Bulb-Tee beam bridge with one integral abutment and one full height abutment.
- Perform full-depth pavement reconstruction along SR 3014 for approximately 200 feet.
- Complete pavement marking, signing, and guide rail improvements.

# SR 3014 Section 554 Jefferson County, PA

# Anticipated Project Schedule

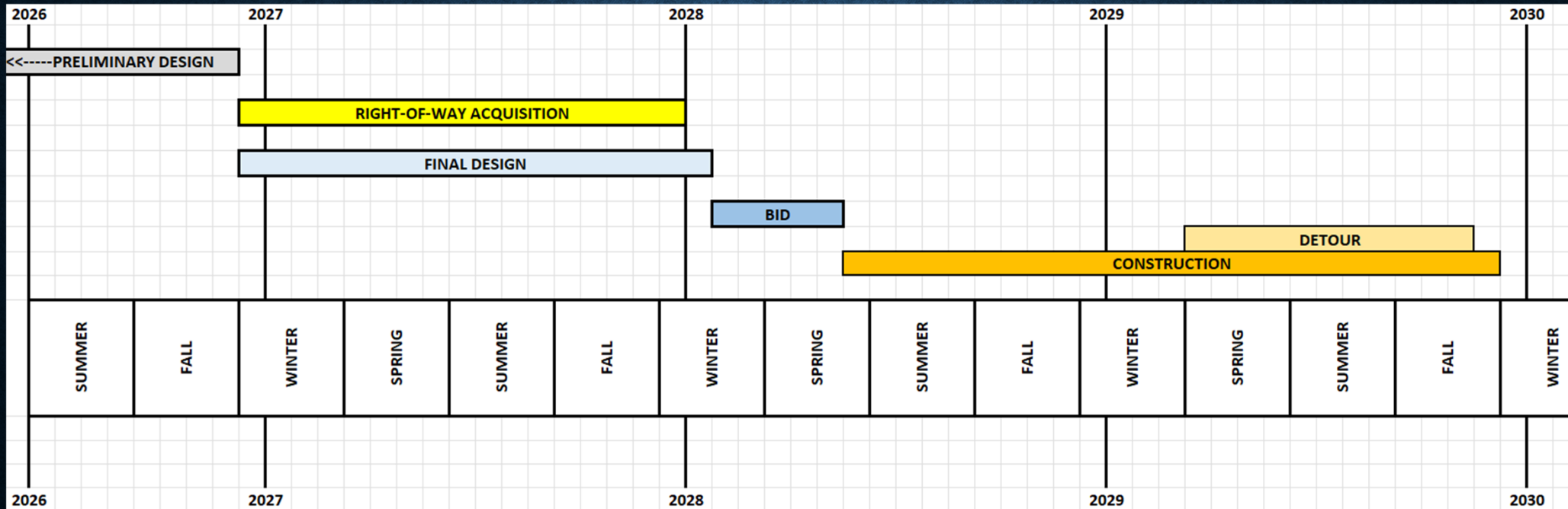

Note: Mauk Hill Road and Barton Chapel Road to remain open during construction.



**SR 3014 Section 554  
Jefferson County, PA**

**Proposed Typical Roadway Section**

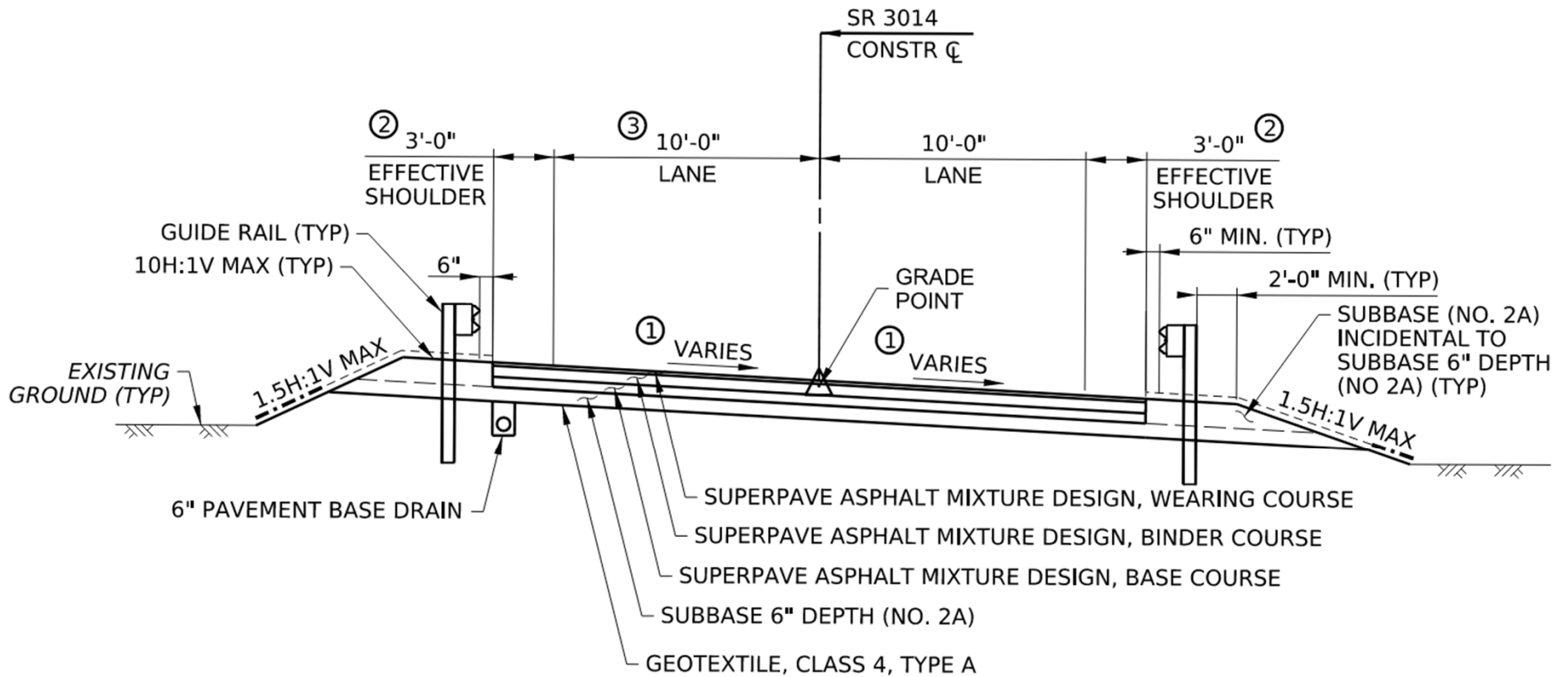

**Full Depth Reconstruction**

**SR 3014 Section 554**  
**Jefferson County, PA**

**Proposed Typical Bridge Section**

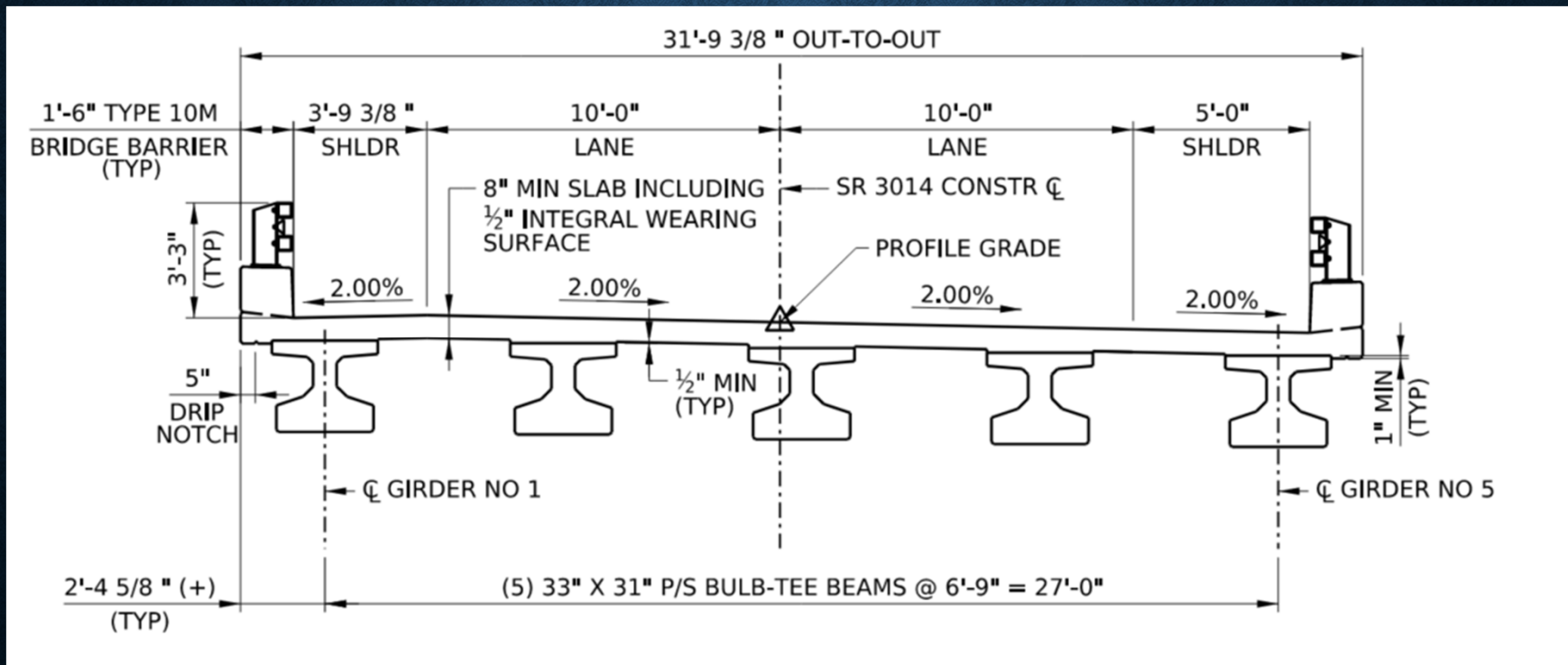

## SR 3014 Section 554 Jefferson County, PA

## Construction Detour

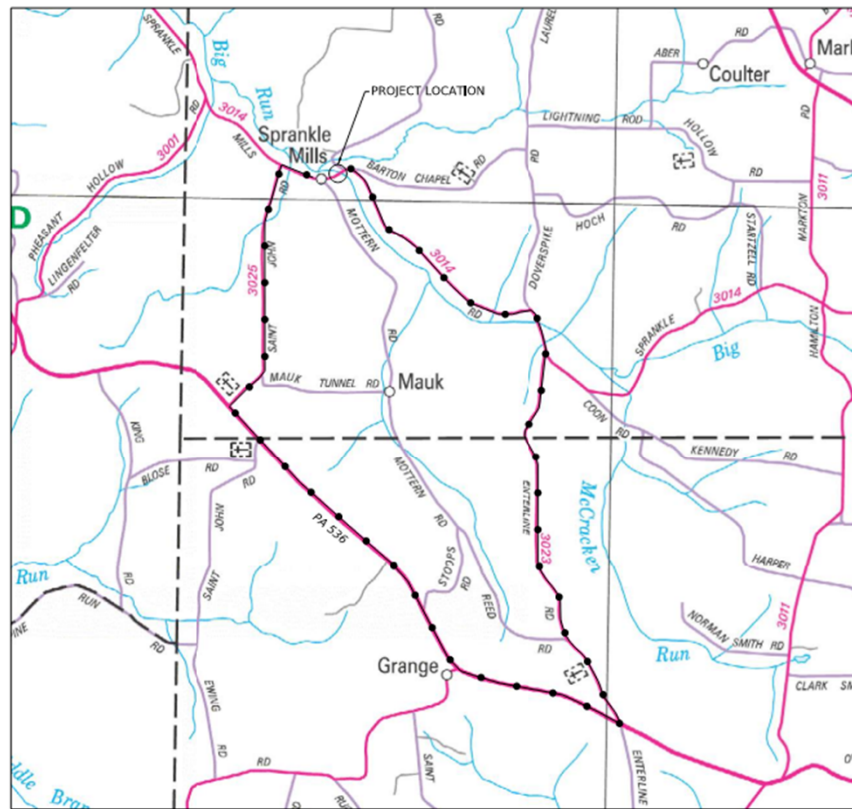

- Preferred method of traffic control – Detour
- Detour Length – 6 miles
- Detour – SR 3014 (Sprankle Mills Rd) to SR 3023 (Enterline Rd) to PA 536 to SR 3025 (Saint John Rd) to SR 3014 (Sprankle Mills Rd)
- Closure Length – Approx. 7 months
- T-359 (Mauk Hill Rd) and T-891 (Barton Chapel Rd) to remain open - single lane and temporary signals

**Please complete the Project Survey**

- The project survey can be found on the project website.
- Click the tile under resources labeled “Submit Comments” on the right-hand side of the screen.

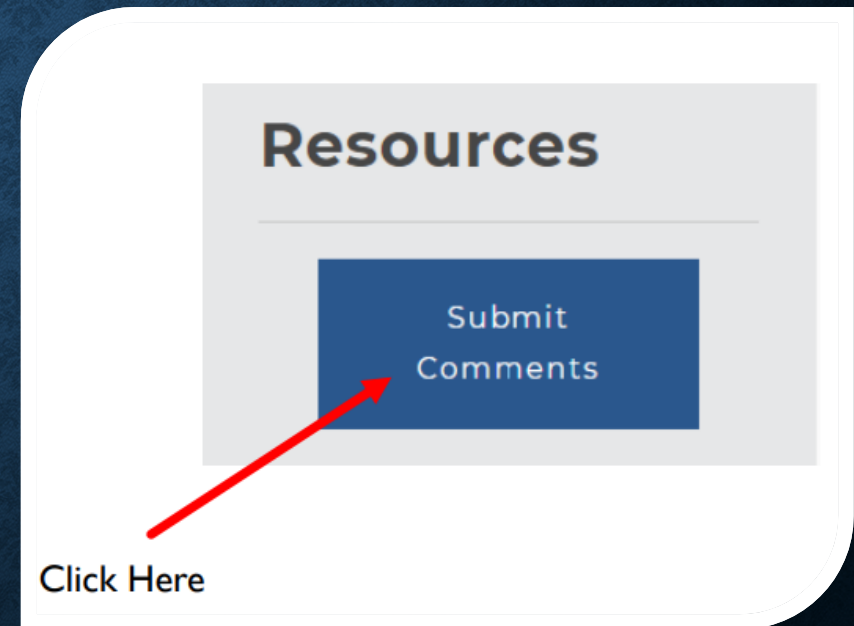

**SR 3014 Section 554**  
**Jefferson County, PA**

Questions?

Contact the PennDOT Project Manager by phone or email if you have any questions or concerns:

**Josh Allen, PE**

- Phone: 724-427-3556
- Email: [joshallen@pa.gov](mailto:joshallen@pa.gov)